

# Variable Frequency Drive xD1000

0.37-30.0kW (3Ph, 380-460VAC)



Embedded Modbus Serial Link Manual

---

## Legal Information

The Lauritz Knudsen Electrical & Automation brand and any trademarks of Lauritz Knudsen Electrical & Automation and its subsidiaries referred to in this guide are the property of Lauritz Knudsen Electrical & Automation or its subsidiaries. All other brands may be trademarks of their respective owners.

This guide and its content are protected under applicable copyright laws and furnished for informational use only. No part of this guide may be reproduced or transmitted in any form or by any means (electronic, mechanical, photocopying, recording, or otherwise), for any purpose, without the prior written permission of Lauritz Knudsen Electrical & Automation.

Lauritz Knudsen Electrical & Automation does not grant any right or license for commercial use of the guide or its content, except for a non-exclusive and personal license to consult it on an "as is" basis. Lauritz Knudsen Electrical & Automation products and equipment should be installed, operated, serviced, and maintained only by qualified personnel.

As standards, specifications, and designs change from time to time, information contained in this guide may be subject to change without notice.

To the extent permitted by applicable law, no responsibility or liability is assumed by Lauritz Knudsen Electrical & Automation and its subsidiaries for any errors or omissions in the informational content of this material or consequences arising out of or resulting from the use of the information contained herein.

# Contents

---

Important Safety Information	4
Before you begin	5
Documentation structure	7
Presentation	8
Connection to RS485 bus	9
Configuration of the Modbus serial port	10
IO Scanner configuration parameters	11
Modbus Functions	13
xD1000 state machine	18
Connection to RS485 bus	22

# Important Safety Information

---

## NOTICE

Read these instructions carefully, and look at the equipment to become familiar with the device before trying to install, operate, or maintain it. The following special messages may appear throughout this documentation or on the equipment to warn of potential hazards or to call attention to information that clarifies or simplifies a procedure.



The addition of this symbol to a Danger or Warning safety label indicates that an electrical hazard exists, which will result in personal injury if the instructions are not followed.



This is the safety alert symbol. It is used to alert you to potential personal injury hazards. Obey all safety messages that follow this symbol to avoid possible injury or death.

## **DANGER**

**DANGER** indicates an imminently hazardous situation, which, if not avoided, **will result** in death or serious injury.

## **WARNING**

**WARNING** indicates a potentially hazardous situation, which, if not avoided, **can result** in death or serious injury.

## **CAUTION**

**CAUTION** indicates a potentially hazardous situation, which, if not avoided, **can result** in minor or moderate injury.

## **NOTICE**

**NOTICE**, used without the safety alert symbol, indicates a potentially hazardous situation which, if not avoided, **can result** in property damage.

## PLEASE NOTE

The word "drive" as used in this manual refers to the controller portion of the adjustable speed drive as defined by NEC.

Electrical equipment should be installed, operated, serviced, and maintained only by qualified personnel. No responsibility is assumed by Lauritz Knudsen Electrical & Automation for any consequences arising out of the use of this material.

© 2024 Lauritz Knudsen Electrical & Automation. All rights reserved.

## Before you begin

Read and understand these instructions before performing any procedure with this drive.

### DANGER

#### HAZARD OF ELECTRIC SHOCK, EXPLOSION, OR ARC FLASH

- Only appropriately trained persons who are familiar with and understand the contents of this manual and all other pertinent product documentation and who have received safety training to recognize and avoid hazards involved are authorized to work on and with this drive system. Installation, adjustment, repair, and maintenance must be performed by qualified personnel.
- The system integrator is responsible for compliance with all local and national electrical code requirements as well as all other applicable regulations with respect to grounding of all equipment.
- Many components of the product, including the printed circuit boards, operate with mains voltage. Do not touch. Use only electrically insulated tools.
- Do not touch unshielded components or terminals with voltage present.
- Motors can generate voltage when the shaft is rotated. Before performing any type of work on the drive system, block the motor shaft to prevent rotation.
- AC voltage can couple voltage to unused conductors in the motor cable. Insulate both ends of unused conductors of the motor cable.
- Do not short across the DC bus terminals or the DC bus capacitors or the braking resistor terminals.
- Before performing work on the drive system:
  - Disconnect all power, including external control power that may be present.
  - Place a "Do Not Turn On" label on all power switches.
  - Lock all power switches in the open position.
  - Wait 15 minutes to allow the DC bus capacitors to discharge. The DC bus LED is not an indicator of the absence of DC bus voltage that can exceed 800Vdc.
  - Measure the voltage on the DC bus between the DC bus terminals using a properly rated voltmeter to verify that the voltage is < 42Vdc.
  - If the DC bus capacitors do not discharge properly, contact your local Lauritz Knudsen Electrical & Automation representative.
- Install and close all covers before applying voltage.

Failure to follow these instructions will result in death or serious injury.

### DANGER

#### UNINTENDED EQUIPMENT OPERATION

- Read and understand this manual before installing or operating the xD1000 drive.
- Any changes made to the parameter settings must be performed by qualified personnel.

Failure to follow these instructions will result in death or serious injury.

### WARNING

#### DAMAGED DRIVE EQUIPMENT

Do not operate or install any drive or drive accessory that appears damaged.

Failure to follow these instructions can result in death, serious injury, or equipment damage.

### **WARNING**

#### **LOSS OF CONTROL**

- The designer of any control scheme must consider the potential failure modes of control paths and, for critical control functions, provide a means to achieve a safe state during and after a path failure. Examples of critical control functions are emergency stop, overtravel stop, power outage, and restart.
- Separate or redundant control paths must be provided for critical control functions.
- System control paths may include communication links. Consideration must be given to the implications of unanticipated transmission delays or failures of the link.
- Observe all accident prevention regulations and local safety guidelines. (a)
- Each implementation of the product must be individually and thoroughly tested for proper operation before being placed into service.

**Failure to follow these instructions can result in death, serious injury or equipment damage.**

a. For USA: Additional information, refer to NEMA ICS 1.1 (latest edition), "Safety Guidelines for the Application, Installation, and Maintenance of Solid State Control" and to NEMA ICS 7.1 (latest edition), "Safety Standards for Construction and Guide for Selection, Installation and Operation of Adjustable Speed Drive Systems."

## Documentation structure

---

The following xD1000VFD technical documents are available on the Lauritz Knudsen Electrical & Automation website <https://www.lk-ea.com>

### xD1000 Quick Start Guide **SP51101** (English)

The Quick Start Guide is delivered with the drive and describes how to wire and configure the drive to start motor quickly and simply for simple applications.

### xD1000 Complete Parameters list **SP51102** (English)

This manual gives the full parameter list of the drive in english.

### xD1000 User manual **SP51099** (English)

This manual describes how to install, program and operate the drive.

### xD1000 Modbus Communication manual **SP51100** (English)

This manual describes the assembly, connection to the bus or network, signaling, diagnostics, and configuration of the communication-specific parameters via the 7 segment LED display.

It also describes the communication services of the Modbus protocol.

This manual includes all Modbus addresses. It explains the operating mode specific to communication (state chart).

### xD1000 Modbus parameters description file

All the parameters are grouped together in an Excel file with the following data:

- Code
- Name
- Modbus Addresses
- Category
- Read/write access
- Type: signed numerical, unsigned numerical, etc.
- Unit
- Factory setting
- Minimum value
- Maximum value
- Display on the 7-segment integrated display terminal
- Relevant menu
- This file offers the option of sorting and arranging the data according to any criterion chosen by the user.

## DANGER

### UNINTENDED EQUIPMENT OPERATION

- Read and understand this manual before installing or operating the xD1000 drive.
- Any changes made to the parameter settings must be performed by qualified personnel.
- The excel file does not describe the behaviour of the parameters. Before any modification, refer to the xD1000 User Manual.

**Failure to follow these instructions will result in death or serious injury.**

# Presentation

---

The Modbus socket on the xD1000 can be used for the following functions:

- Configuration
- Settings
- Control
- Monitoring

The xD1000 fc drive supports:

- The 2-wire RS485 physical layer
- The RTU transmission mode

# Connection to RS485 bus

## Connection to xD1000

Connection accessories should be ordered separately (please consult our catalogues).

Connect the RJ45 cable connector to the xD1000 connector.

### Pin out of the xD1000 RJ45 Connector

View from underneath

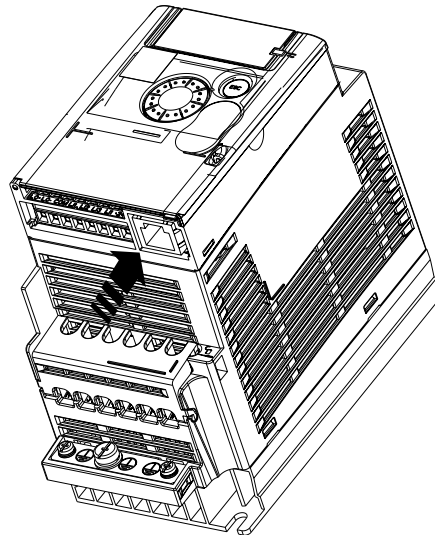
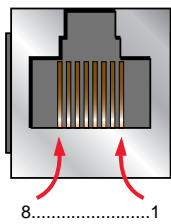

Pin	Signal
1	Reserved
2	
3	
4	D1 (1) is defined as '+' pin
5	D0 (1) is defined as '-' pin
6	Reserved
7	VP <b>Note:</b> Supply for RS232 / RS485 converter or a remote terminal.
8	Common (1)

**NOTICE**

**RISK OF SERIAL PORT DAMAGE**  
Do not connect shield layer of the cable to Common (pin8).  
**Failure to follow these instructions can result in equipment damage.**

(1) Modbus signals.

## Protection against interference

- Use the cable with 2 pairs of shielded twisted conductors.
- Keep the Modbus cable separated from the power cables (30 cm (11.8 in.) minimum).
- Make any crossovers of the Modbus cable and the power cables at right-angles, if necessary.

## RS485 bus schematic

The RS485 standard allows variants of different characteristics:

- polarisation
- line terminator
- distribution of a reference potential
- number of slaves
- length of bus

The new Modbus specification published on the Modbus.org site in 2002 contains precise details of all these characteristics. They are also summarised in Standard schematic section. The new Lauritz Knudsen Electrical & Automation devices conform to this specification.

# Configuration of the Modbus serial port

## Communication Menu Structure

The communication parameters are part of the COM- submenu.  
This menu is accessible as follows:

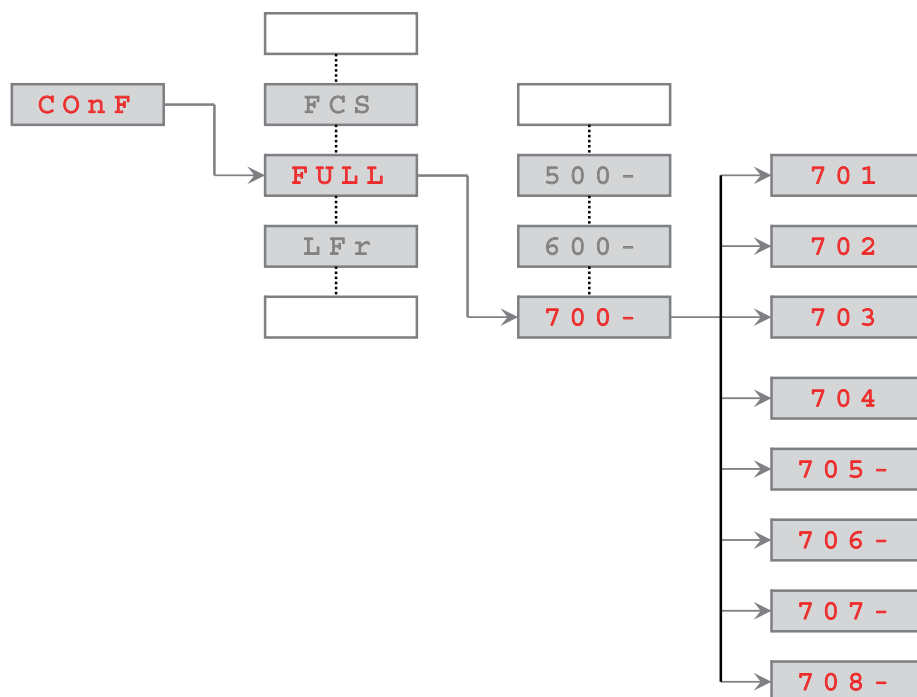

## Communication configuration - Parameters description

Parameter description	Range or listed values	default	Possible Value	Modbus address
MODBUS address of the drive <b>701</b>	1 to 247 0: OFF (broadcast only)	OFF	<b>OFF</b> <b>1...247</b>	16#1771 = 06001
MODBUS baud rate <b>702</b>	4.8 kbps 9.6 kbps 19.2 kbps 38.4 kbps	19.2 kbps	<b>4.8</b> <b>9.6</b> <b>19.2</b> <b>38.4</b>	16#1773 = 06003
MODBUS format <b>703</b>	8O1: 8 bits, odd parity, 1 stop bit. 8E1: 8 bits, even parity, 1 stop bit. 8N1: 8 bits, no parity, 1 stop bit 8N2: 8 bits, no parity, 2 stop bits.	8E1	<b>8o1</b> <b>8E1</b> <b>8n1</b> <b>8n2</b>	16#1774 = 06004
MODBUS Time out <b>704</b>	Adjustable from 0.1 to 30s	10.0 s	<b>0.1...30</b>	16#1775 = 06005
<b>705 -</b>	Communication scanner submenus :Detailed in the next chapter			
<b>706 -</b>				
<b>707 -</b>				
<b>708 -</b>				

The behaviour of the xD1000 when a time-out occurs is defined by the **611** parameter, this parameter can be found in the menu **600-** (see User Manual).

### **⚠ WARNING**

#### **LOSS OF CONTROL**

If **Modbus fault management (611) = fault ignore (00)**, communication control will be inhibited. For safety reasons, inhibition of communication fault should only be used for adjustment or special applications purpose.

**Failure to follow these instructions can result in death, serious injury, or equipment damage.**

# IO Scanner configuration parameters

## Integrated communication scanner

The communication scanner is useful when used in combination by the Modbus client device with the function "Read/Write Multiple registers" : 23 (0x17), which provides in a single telegram a read multiple registers and a write multiple registers. The detail of the function 23 is described in the supported Modbus functions

## Local configuration of the communication scanner

The communication scanner is accessible via the following menus : **700 -** and **705 - 706 -** submenus.

The 4 output variables and the 4 input variables are assigned by means of parameters **706.0** to **706.3** and **705.0** to **705.3**. An **706** or **705** parameter with a value of zero indicates that the parameter is not active. These 8 parameters are described in the table.

NCA or NMA defines the addresses. All these parameters are Modbus eligible addresses.

Submenu	On the local HMI, it is parameter description	Factory setting parameter	Modbus address
<b>705 -</b>	NMA1 ( <b>705.0</b> ) Source drive address of the 1st input word	Address of ETA=3201 16#0C81	705.0 address 16#319D = 12701
	NMA2 ( <b>705.1</b> ) Source drive address of the 2nd input word	Address of RFRD=8604 16#219C	705.1 address 16#319E = 12702
	NMA3 ( <b>705.2</b> ) Source drive address of the 3rd input word	0	705.2 address 16#319F = 12703
	NMA4 ( <b>705.3</b> ) Source drive address of the 4th input word	0	705.3 address 16#31A0 = 12704
<b>706 -</b>	NCA1 ( <b>706.0</b> ) Destination drive address of the 1st output word	Address of CMD=8501 16#2135	706.0 address 16#31B1 = 12721
	NCA2 ( <b>706.1</b> ) Destination drive address of the 2nd output word	Address of LFRD=8602 16#219A	706.1 address 16#31B2 = 12722
	NCA3 ( <b>706.2</b> ) Destination drive address of the 3rd output word	0	706.2 address 16#31B3 = 12723
	NCA4 ( <b>706.3</b> ) Destination drive address of the 4th output word	0	706.3 address 16#31B4 = 12724

## Monitoring the communication scanner

It is also possible to monitor the parameters value that have been configured in the communication scanner. This monitored values are accessible via the following menus : **700 -** and **707 - 708 -** submenu.

The 4 output variable values and the 4 input variable values are located into parameters **708.0** to **708.3** and **707.0** to **707.3**.

Submenu	On the local HMI, it is parameter description	Factory setting parameter	Modbus address
<b>707 -</b>	NM1 ( <b>707.0</b> ) Source drive value of the 1st input word	ETA value	707.0 address 16#31C5 = 12741
	NM2 ( <b>707.1</b> ) Source drive value of the 2nd input word	RFRD value	707.1 address 16#31C6 = 12742
	NM3 ( <b>707.2</b> ) Source drive value of the 3rd input word	0	707.2 address 16#31C7 = 12743
	NM4 ( <b>707.3</b> ) Source drive value of the 4th input word	0	707.3 address 16#31C8 = 12744
<b>708 -</b>	NC1 ( <b>708.0</b> ) Destination drive value of the 1st input word	CMD value	708.0 address 16#31D9 = 12761
	NC2 ( <b>708.1</b> ) Destination drive value of the 2nd input word	LFRD value	708.1 address 16#31DA = 12762
	NC3 ( <b>708.2</b> ) Destination drive value of the 3rd input word	0	708.2 address 16#31DB = 12763
	NC4 ( <b>708.3</b> ) Destination drive value of the 4th input word	0	708.3 address 16#31DC = 12764

# IO Scanner configuration parameters

## Configuration example

In this example the communication scanner is configured as follow, **706.0**, **706.1**, **705.0**, **705.1** are used with their default values. **706.2** is configured with the address of **CPI**, Extended control word (Modbus 8504 16#2138). **705.2** is configured with the address of **EI**, Extended control word (Modbus 3206 16#0C86).

### How to read the diagram below

Example for **706.2**:

**706.2** (1) contain the logical address (**2138**) of **CPI**, Extended control word (2)

#### Communication scanner

- menu **700-**
- submenu **700-, 706-**

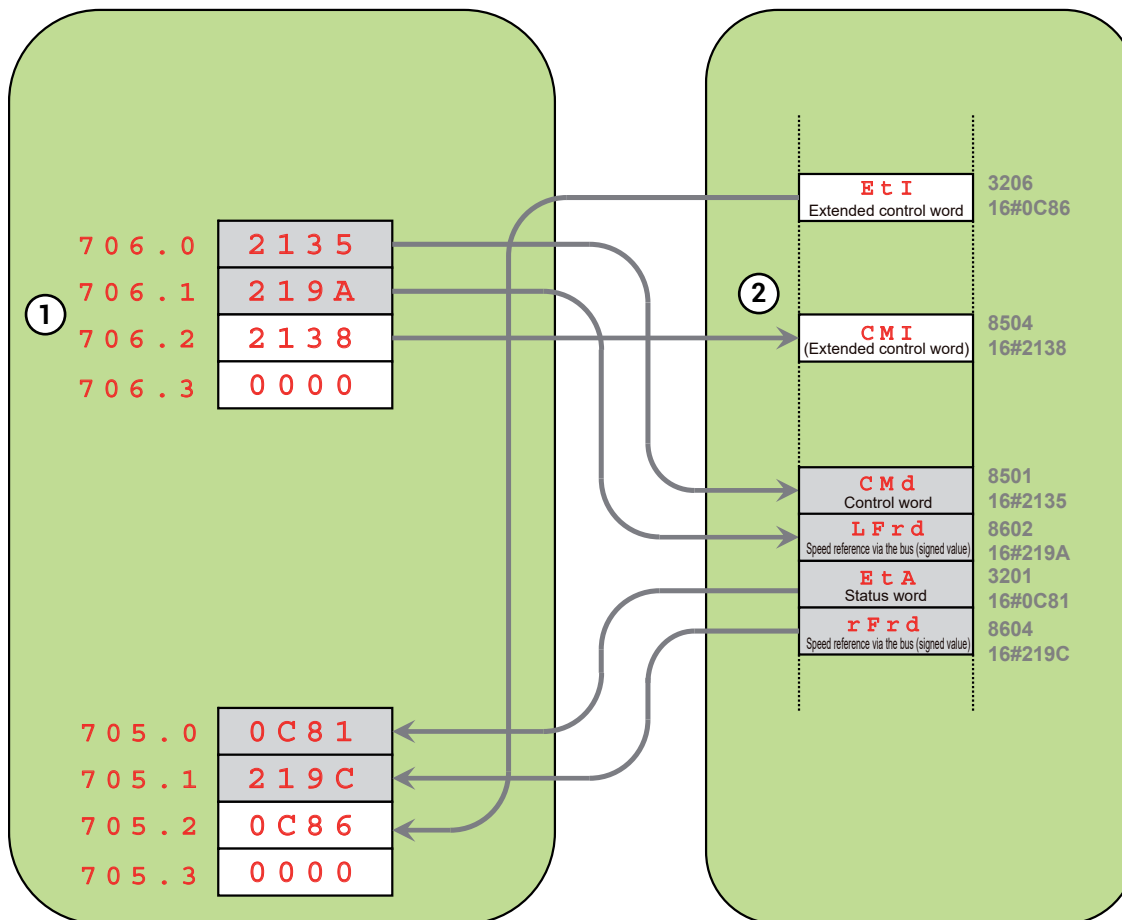

The required telegram to perform the exchange is the Modbus function 23, Obviously a sequence of requests based on Modbus functions 03 and 16 is also possible.

# Modbus Functions

## Modbus Protocol

The transmission mode used is RTU mode. The frame contains no message header byte, nor end of message bytes. It is defined as follows:



The data is transmitted in binary code.

CRC16: cyclical redundancy check.

The end of the frame is detected on a silence greater than or equal to 3 characters.

## Principle

The Modbus protocol is a master-slave protocol.

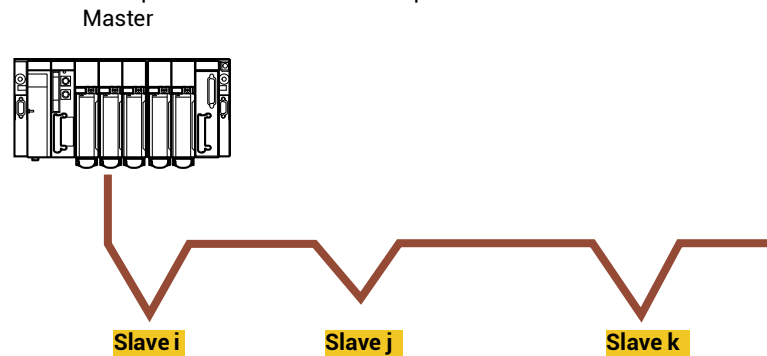

Only one device can transmit on the line at any time. The master manages the exchanges and only it can take the initiative. It interrogates each of the slaves in succession. No slave can send a message unless it is invited to do so. The master repeats the question when there is an incorrect exchange, and declares the interrogated slave absent if no response is received within a given time period. If a slave does not understand a message, it sends an exception response to the master. The master may or may not repeat the request.

Direct slave-to-slave communications are not possible.

For slave-to-slave communication, the application software must therefore be designed to interrogate a slave and send back data received to the other slave.

Two types of dialogue are possible between master and slaves:

- the master sends a request to a slave and waits for its response
- the master sends a request to all slaves without waiting for a response (broadcasting principle)

## Addresses

- The drive Modbus address can be configured from 1 to 247.
- Address 0 coded in a request sent by the master is reserved for broadcasting. xD1000 drives take account of the request, but do not respond to it.

## Supported Modbus functions

The xD1000 supports the following Modbus functions.

Function name	Code	Description	Remarks
Read holding registers	03 16#03	Read N output words	Max PDU length : 63 words
Write one output word	06 16#06	Write one output word	
Write multiple registers	16 16#10	Write N output word	Max PDU length : 61 words
Read/write Multiple registers	23 16#17	Read/write multiple registers	Max PDU length : 4 words (W), 4 words (R)
(Sub-function) Read device Identification	43/14 16#2B 16#0E	Encapsulated interface transport / Read device identification	

# Modbus Functions

The following paragraphs describes each supported function.

## Read holding registers

### Request

Function code	1 Byte	0x03
Starting Address	2 Bytes	0x0000 to 0xFFFF
Quantity of Registers	2 Bytes	1 to 63 (0x 3F)

### Response

Function code	1 Byte	0x03
Byte count	1 Byte	2 x N*
Register value	N* x 2 Bytes	

\*N: Quantity of Registers

### Error

Error code	1 Byte	0x83
Exception code	1 Byte	01 or 02 or 03 or 04 (see details on 17)

### Example

**Note:** Hi = high order byte, Lo = low order byte.

This function can be used to read all xD1000 words, both input words and output words.

#### Request

Slave no.	03	No. of first word		Number of words		CRC16	
		Hi	Lo	Hi	Lo	Lo	Hi
1 byte	1 byte	2 bytes		2 bytes		2 bytes	

#### Response

Slave no.	03	Number of bytes read	First word value		Last word value		CRC16	
			Hi	Lo	Hi	Lo	Lo	Hi
1 byte	1 byte	1 byte	2 bytes		2 bytes		2 bytes	

Example: read 4 words W3102 to W3105 (16#0C1E to 16#0C21) in slave 2, using function 3, where:

- 315 = Switching frequency = 4 kHz (W3102 = 16#0028)
- 308 = Maximum output frequency = 60 Hz (W3103 = 16#0258)
- 512.2 = High speed = 50 Hz (W3104 = 16#01F4)
- LSP = Low speed = 0 Hz (W3105 = 16#0000)

Request	02	03	0C1E	0004	276C
---------	----	----	------	------	------

Response	02	03	08	0028	0258	01F4	0000	52B0
	Value of:			W3102	W3103	W3104	W3105	
	Parameters:			315	308	512.2	512.0	

# Modbus Functions

## Write one output word

### Request

Function code	1 Byte	0x06
Register Address	2 Bytes	0x0000 to 0xFFFF
Register value	2 Bytes	0x0000 to 0xFFFF

### Response

Function code	1 Byte	0x06
Register Address	2 Bytes	0x0000 to 0xFFFF
Register value	2 Bytes	0x0000 to 0xFFFF

### Error

Error code	1 Byte	0x86
Exception code	1 Byte	01 or 02 or 03 or 04 (see details on 17)

### Example

Request and response (the frame format is identical)

Slave no.	06	Word number		Value of word		CRC16	
		Hi	Lo	Hi	Lo	Lo	Hi
1 byte	1 byte	2 bytes		2 bytes		2 bytes	

Example: write value 16#000D in word W9001 (16#2329) in slave 2 (ACC = 13 s).

Request and response	02	06	2329	000D	9270
----------------------	----	----	------	------	------

## Read/write Multiple registers

Description	Length in byte	Value	Comment
Function code	1	16#17	
Read starting address	2	16#XXXX	Always Modbus address
Quantity to read	2	16#03	Contain number of holding registers to be read.
Write starting address	2	16#XXXX	Always Modbus address
Quantity to write	2	16#03	Contain number of holding registers to be written.
Write Byte count	1	16#06	The byte count specifies the number of bytes to follow in the field Write Register Value.
Write Registers Value	Nx2 Bytes (N: quantity to write)	16#XX XXXX XXXX XX	Value to be written respectively in 706.0 to 706.2, so the configured example: CMD, LFRD, CMI.

### Example

Slave n°	Function Code	Read starting Address HI	Read starting Address LOW	Qty	Write starting Address HI	Write starting Address LOW	Qty
1 byte	1 byte	1 byte	1 byte	2 byte	1 byte	1 byte	2 byte

Write byte count	Writing Value 1 HI	Value 1 Lo		Value 1 HI	Writing Value 1.. 2... 3...n ...	CRC16
1 byte	1 byte	1 byte		1 byte	1 byte	2 byte

# Modbus Functions

## Read Device Identification

ID	Name / Description	Type
0x00	VendorName	ASCII String
0x01	ProductCode	ASCII String
0x02	MajorMinorRevision	ASCII String

### Example

#### Default values to be detailed

Request

Slave no.	2B	Type of MEI 0E	ReadDeviceId 01	Object Id 00	CRC16	
					Lo	Hi
1 byte	1 byte	1 byte	1 byte	1 byte	2 bytes	

Response

Slave no.	2B	Type of MEI 0E	ReadDeviceId 01	Degree of conformity 02	----- --
1 byte	1 byte	1 byte	1 byte	1 byte	

----- --	Number of additional frames 00	Next object Id 00	Number of objects 03	----- --
	1 byte	1 byte	1 byte	

----- --	Id of object no. 1 00	Length of object no. 1 12	Value of object no. 1 "Lauritz Knudsen Electrical & Automation"	----- --
	1 byte	1 byte	18 bytes	

----- --	Id of object no. 2 01	Length of object no. 2 0B	Value of object no. 2 "xD1000H037N4"	----- --
	1 byte	1 byte	12 bytes	

----- --	Id of object no. 3 02	Length of object no. 3 04	Value of object no. 3 "0201"	----- --
	1 byte	1 byte	4 bytes	

----- --	CRC16	
	Lo	Hi
	1 byte	1 byte

The total response size equals 50 bytes

The three objects contained in the response correspond to the following objects:

- Object no. 1: Manufacturer name (always "Lauritz Knudsen Electrical & Automation", ie. 18 bytes).
- Object no. 2: Device reference (ASCII string; *for example*: "xD1000H037N4", ie. 12 bytes).
- Object no. 3: Device version, in "MMmm" format where "MM" represents the determinant and "mm" the subdeterminant (4-bytes ASCII string; *for example*: "0201" for version 2.1).

**Note:** The response to function 43 may be negative; in this case, the response located at the top of the next page is sent by the xD1000 rather than the response described above.

# Modbus Functions

---

## Error management

### Exception responses

An exception response is returned by a slave when it is unable to perform the request which is addressed to it.

Format of an exception response:

Slave no.	Response code	Error code	CRC16	
			Lo	Hi
1 byte	1 byte	1 byte	2 bytes	

**Response code:** request function code + 16#80.

**Error code:**

- 1 = The function requested is not recognized by the slave
- 2 = The bit or word addresses indicated in the request do not exist in the slave
- 3 = The bit or word values indicated in the request are not permissible in the slave
- 4 = The slave has started to execute the request but cannot continue to process it completely

### CRC16 calculation

The CRC16 is calculated on all the message bytes by applying the following method:

Initialize the CRC (16-bit register) to 16#FFFF.

Enter the first to the last byte of the message:

```
CRC      XOR      <byte> -> CRC
Enter    8 times
         Move the CRC one bit to the right
         If the output bit = 1, enter CRC XOR 16#A001 -> CRC
End enter
End enter
```

The CRC obtained will be transmitted with the low order bytes sent first, followed by the high order ones (unlike the other data contained in Modbus frames).

XOR = exclusive OR.

# xD1000 state machine

## Status chart based on IEC 61800-7\*

The state machine below describes the interaction between the drive's state machine, monitored by the status word (ETA) parameter, and the Command Word (CMD). CiA® and CANopen® are registered Community Trademarks of CAN in Automation e.V.

\*:Since 2007, CiA402 profile is part of the IEC standard 61800-7. Therefore DriveCom or CiA402 terminology is no more used.

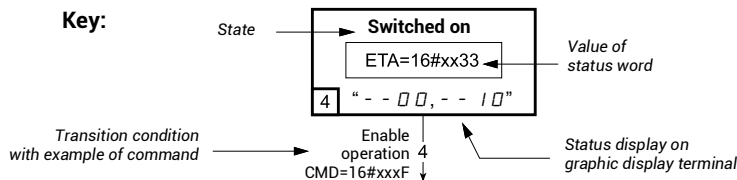
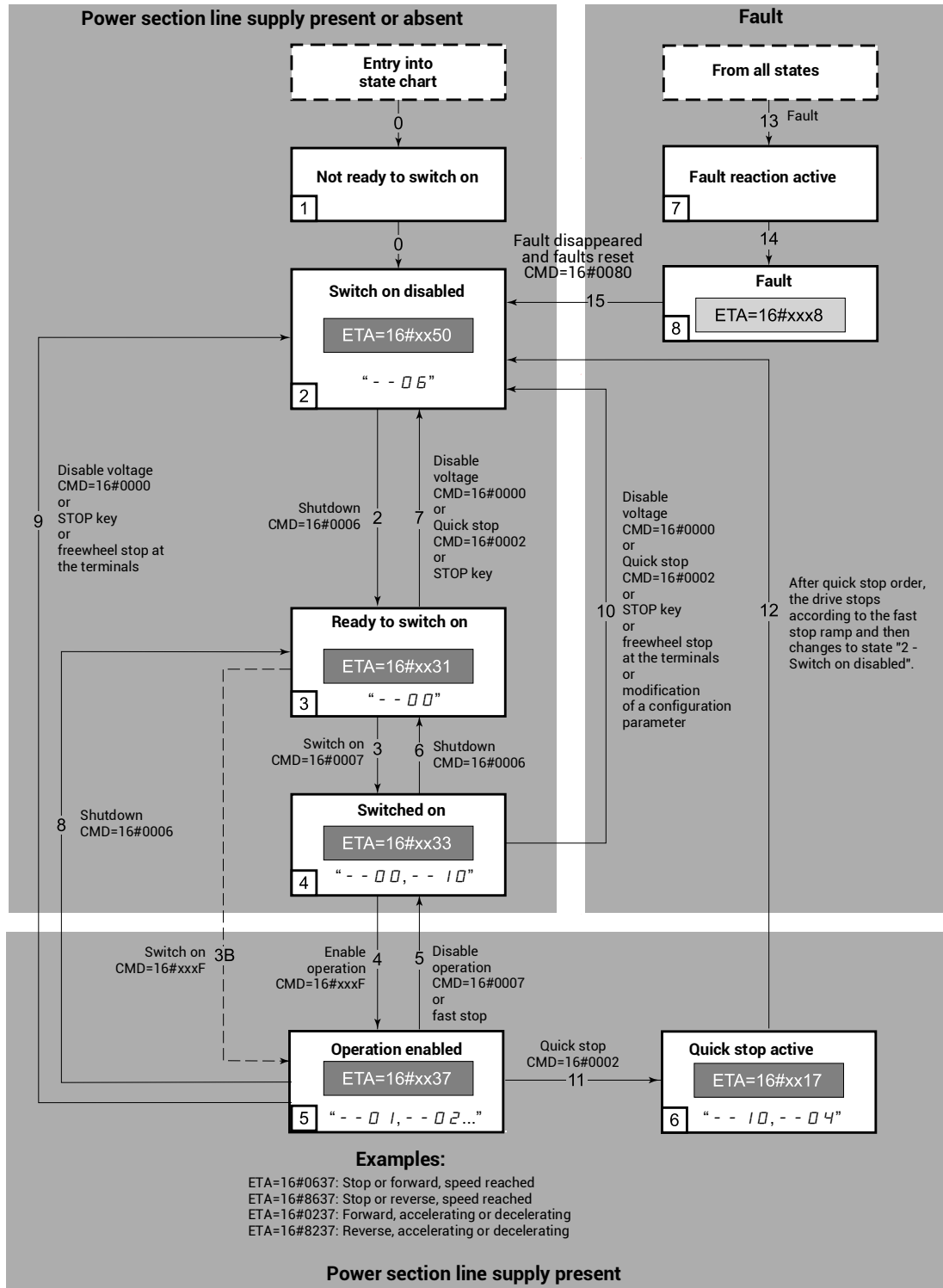

# xD1000 state machine

---

## State machine description

The xD Series VFD control process using the communication bus follows IEC 61800-7 profile status chart compatible with the DRIVCOM standard. Each state represents an aspect of the internal behaviour of the drive.

This chart evolves according to whether the control word is sent (CMD W8501) or an event occurs (example: lock following malfunction). The drive status can be identified by the value of the status word (ETA W3201).

### Not ready to switch on (Initialization):

Communication is being initialized.  
Transient state invisible to the communication bus.

### Switch on disabled (Configuration):

Initialization of the drive is complete.  
The configuration and adjustment parameters can be modified. The drive is locked.

### Ready to switch on and Switched on (Drive initialized):

The drive is locked.  
The power stage of the drive is ready to operate, but voltage has not yet been applied to the output.  
The configuration and adjustment parameters can be modified, but modifying a configuration parameter returns the drive to the "Switch on disabled" state.

### Operation enabled (Operational):

The drive is unlocked and voltage can be applied to the motor terminals.  
Auto-tuning (tUn) requires an injection of current. The drive must therefore be in this state to perform this command.  
The adjustment parameters can be modified even if a run command or a DC injection current is present. However, a configuration parameter can only be modified if the motor is stopped, and this returns the drive to the "Switch on disabled" state.

### Quick stop active (Emergency stop active):

Fast stop  
Restarting is only possible after the drive has changed to the "Switch on disabled" state.

### Malfunction reaction active (Reaction on fault):

Transient state during which the drive performs an action appropriate to the type of fault detection.

### Malfunction (Fault):

The drive is locked.

## Summary

State	Power supplied to motor	Modification of configuration parameters
1 - Not ready to switch on	No	Yes
2 - Switch on disabled	No	Yes
3 - Ready to switch on	No	Yes
4 - Switched on	No	Yes, return to "2 - Switch on disabled" state
5 - Operation enabled	Yes, except at zero reference or "halt"	No
6 - Quick stop active	Yes, during fast stop	No
7 - Fault reaction active	Depends on fault management configuration	-
8 - Fault	No	Yes

## xD1000 state machine

### Command word description CMD - 8501

bit 7	bit 6	bit 5	bit 4	bit 3	bit 2	bit 1	bit 0
0 to 1 transition : Fault reset	Reserved (=0)	Reserved (=0)	0:Free wheel staying in "Operation Enabled"	Enable operation Drivecom state activation	Quick stop Drivecom state activation (bit active at 0)	Switch on disabled. Drivecom state activation (bit active at 0)	Switch on

bit 15	bit 14	bit 13	bit 12	bit 11	bit 10	bit 9	bit 8
Reserved	Not assignable	Reserved	Reserved	Direction of rotation asked 0: Forward 1: Reverse	Reserved (=0)	Reserved (=0)	Set to 1: Halt Stop according to the <b>[Type of stop (502.0)]</b> parameter without leaving the Operation enabled state

Command	Transition address	Final state	bit 7	bit 3	bit 2	bit 1	bit 0	Example value
			Fault reset	Enable operation	Quick stop	Switch on disabled	Switch on	
Shutdown	2, 6, 8	3 - Ready to switch on	x	x	1	1	0	16#0006
Switch on	3	4 - Switched on	x	x	1	1	1	16#0007
Enable operation	4	5 - Operation enabled	x	1	1	1	1	16#000F
Disable operation	5	4 - Switched on	x	0	1	1	1	16#0007
Disable voltage	7, 9, 10, 12	2 - Switch on disabled	x	x	x	0	x	16#0000
Quick stop	11	6 - Quick stop active	x	x	0	1	x	16#0002
	7, 10	2 - Switch on disabled						
Fault reset	15	2 - Switch on disabled	0 → 1	x	x	x	x	16#0080

x: Value is of no significance for this command.  
0 → 1: Command on rising edge.

# xD1000 state machine

## Status word description ETA - 3201

bit 7	bit 6	bit 5	bit 4	bit 3	bit 2	bit 1	bit 0
Reserved (always 0)	Switch on disabled	Quick stop (bit active at 0)	Voltage enabled (bit always on)	Fault detection	Operation enabled	Switched on	Ready to switch on

bit 15	bit 14	bit 13	bit 12	bit 11	bit 10	bit 9	bit 8
0: Motor rotation in forward direction (or stopped)	Stop via STOP key	Reserved (=0)	Reserved (=0)	Reference exceeded (< LSP or > HSP)	Reference reached (steady state)	Local mode (bit active at 0)	Reserved (=0)

Status	bit 6	bit 5	bit 4	bit 3	bit 2	bit 1	bit 0	ETA masked by 16#006F (1)
	Switch on disabled	Quick stop	Voltage enabled	Fault detection	Operation enabled	Switched on	Ready to switch on	
1 - Not ready to switch on	0	x	x	0	0	0	0	-
2 - Switch on disabled	1	x	x	0	0	0	0	16#0050
3 - Ready to switch on	0	1	x	0	0	0	1	16#0031
4 - Switched on	0	1	1	0	0	1	1	16#0033
5 - Operation enabled	0	1	1	0	1	1	1	16#0037
6 - Quick stop active	0	0	1	0	1	1	1	16#0017
7 - Fault reaction active	0	x	x	1	1	1	1	-
8 - Fault	0	x	x	1	0	0	0	16#0018 (2) or 16#0038

x: In this state, the value of the bit can be 0 or 1.

(1) This mask can be used by the PLC program to test the chart state.

(2) Fault following state "6 - Quick stop active".

## Connection to RS485 bus

### Standard schematic

The standard schematic corresponds to the Modbus specification published on the Modbus.org site in 2002 (Modbus\_over\_serial\_line\_V1.pdf, Nov 2002) and in particular to the schematic of the 2-wire multidrop serial bus.

The xD1000 drive follows this specification.

#### Schematic diagram:

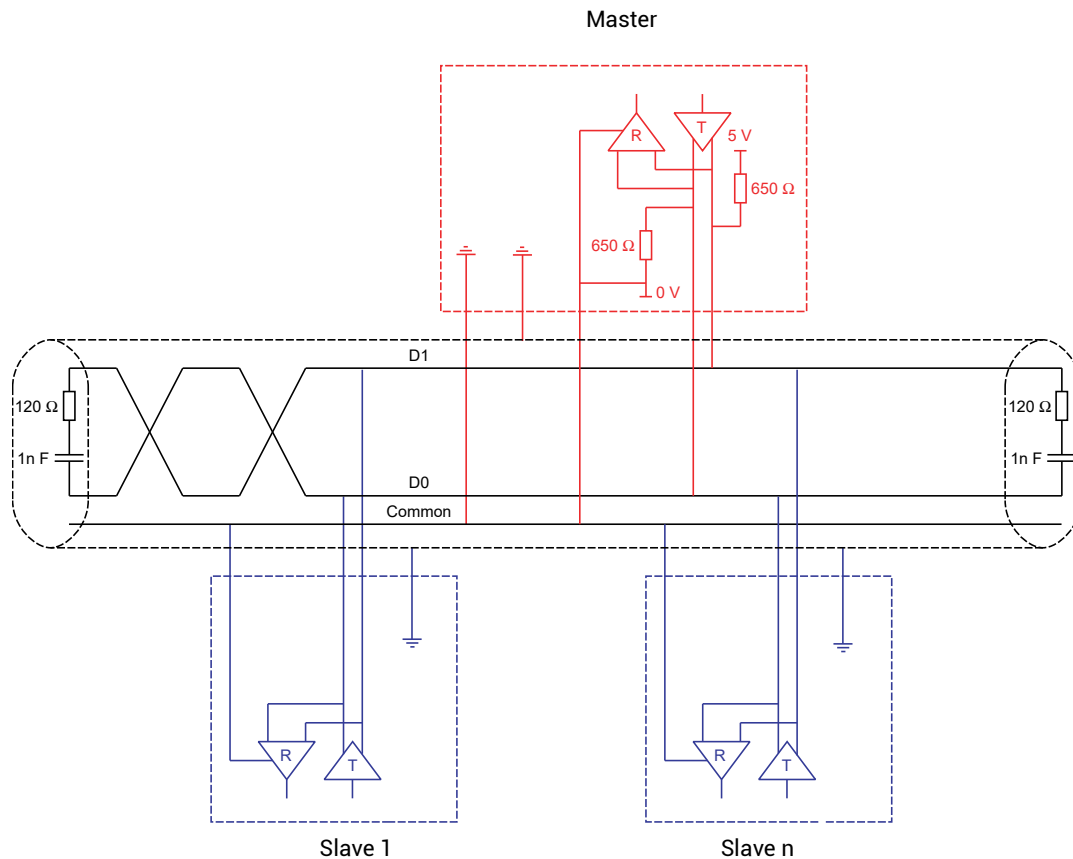

Type of trunk cable	Shielded cable with 1 twisted pair and at least a 3 <sup>rd</sup> conductor
Maximum length of bus	1000 m at 19200 bps
Maximum number of stations (without repeater)	32 stations, ie. 31 slaves
Maximum length of tap links	<ul style="list-style-type: none"> <li>• 20 m for one tap link</li> <li>• 40 m divided by the number of tap links on a multiple junction box</li> </ul>
Bus polarisation	<ul style="list-style-type: none"> <li>• One 450 to 650 Ω pulldown resistor at 5 V (650 Ω recommended)</li> <li>• One 450 to 650 Ω pulldown resistor at the Common (650 Ω recommended)</li> </ul> This polarisation is recommended for the master.
Line terminator	One 120 Ω 0.25 W resistor in series with a 1nF 10 V capacitor
Common polarity	Yes (Common), connected to the protective ground at one or more points on the bus



"This literature gives information to user about product installation, operation maintenance and disposal. This information is not exhaustive and should customer require further information, in specific cases, customer may contact customer interaction cell."

"The manufacturer assumes no responsibility for injuries, losses, damages to human beings and/or equipments due to inappropriate application of instructions, provided herein."

"Product development is a continuous process. The information given in this literature is Subject to change. For latest information the customer may contact customer interaction cell."

"Product images are indicative"



**CUSTOMER  
INTERACTION  
CELL (CIC)**

Phone No: 022 6932 7800  
E-mail: [CIC@LK-EA.COM](mailto:CIC@LK-EA.COM)  
Website: [WWW.LK-EA.COM](http://WWW.LK-EA.COM)



Electrical & Automation

### **Electrical Standard Products**

A/600, SHIL - MAHAPE ROAD,  
TTC Industrial Area, MIDC Thane,  
MUMBAI, MAHARASHTRA, 400710

