



Electrical & Automation



# POWER QUALITY SOLUTIONS

# ABOUT US

Lauritz Knudsen Electrical & Automation, formerly known as L&T Switchgear, is a leading player in the electrical industry owing to its 70+ years of strong legacy and commitment to the nation's growth. The brand is dedicated to providing a wide range of electrical and automation products and solutions to vital sectors of the economy, including industries, utilities, infrastructure, buildings, and agriculture. Our extensive portfolio includes low-voltage and medium-voltage switchgear, automation solutions, tailored software, and services.

With manufacturing operations in Ahmednagar, Vadodara, and Coimbatore, we adhere to global standards of excellence. Our operations are supported by well-equipped, in-house design and development centers, as well as tooling facilities, ensuring precision in manufacturing.

We proudly operate six Switchgear Training Centers (STCs) across Pune, Lucknow, Coonoor, Vadodara, Delhi, and Kolkata. These centers offer tailor-made classroom courses and lab learning experiences for technicians, customers, engineers, professionals, and students.

With a deep national presence and one of the largest electrical distribution networks, comprising over 1500 partners across the country, we are committed to driving excellence and delivering superior products and solutions that power India's growth journey.

# Contents

|   |           |
|---|-----------|
| PRODUCTS OF POWER QUALITY                             | 5         |
| POWER FACTOR CORRECTION                               | 8         |
| BENEFITS OF USING LT CAPACITORS OVER HT CAPACITORS    | 9         |
| CAPACITOR TECHNOLOGY                                  | 11        |
| LIFE OF POWER CAPACITORS                              | 12        |
| CAPACITOR POWER LOSS CALCULATION                      | 13        |
| DISCHARGE RESISTORS                                   | 14        |
| VOLTAGE SELECTION OF POWER CAPACITORS                 | 15        |
| STANDARD DUTY CAPACITORS                              | 16        |
| HEAVY DUTY CAPACITORS                                 | 19        |
| HD PLUS GAS FILLED CAPACITORS                         | 22        |
| SUPER HEAVY DUTY CAPACITORS                           | 24        |
| LT APP CAPACITORS                                     | 26        |
| LTXL: ULTRA HEAVY DUTY CYLINDRICAL CAPACITORS         | 28        |
| LTXL: ULTRA HEAVY DUTY BOX CAPACITORS                 | 30        |
| HARMONICS   | 33        |
| HARMONIC AMPLIFICATION                                | 34        |
| HARMONIC RESONANCE                                    | 35        |
| INTERPRETATION OF TOTAL HARMONIC DISTORTION (THD)     | 37        |
| UNDERSTANDING CURRENT & VOLTAGE HARMONICS             | 39        |
| TRIPLEN HARMONIC MITIGATION                           | 42        |
| HARMONIC MITIGATION                                   | 44        |
| DETUNED FILTERS                                       | 45        |
| IMPORTANCE OF USING THE RIGHT DETUNED REACTOR         | 48        |
| LINEARITY OF REACTOR                                  | 50        |
| IMPACT OF Q-FACTOR ON PERFORMANCE OF DETUNED REACTORS | 51        |
| <b>REACTORS - HARMONIC FILTERS</b>                    | <b>53</b> |
| <b>ACTIVE HARMONIC FILTERS (AHF)</b>                  | <b>56</b> |

|   |     |
|---|-----|
| AHF MODULES   | 67  |
| HARMONICS AND ITS IMPACTS ON POWER FACTOR               | 70  |
| IMPACT OF HARMONICS ON DG SETS                          | 72  |
| <b>ADVANCE STATIC VAR GENERATOR (ASVG)</b>              | 75  |
| CAPACITOR SWITCHING IN APFC PANEL                       | 80  |
| A COMPARATIVE STUDY OF SWITCHING METHODS                | 81  |
| <b>CAPACITOR DUTY CONTACTORS – TYPE MOC</b>             | 86  |
| DIMENSION DETAILS MOC                                   | 90  |
| DYNAMIC POWER FACTOR CORRECTION                         | 92  |
| <b>THYRISTOR SWITCHING MODULES</b>                      | 96  |
| TSM TECHNICAL DETAILS                                   | 97  |
| NETWORK/DIMENSION OF TSM                                | 98  |
| <b>APFC RELAY</b>                                       | 99  |
| TECHNICAL SPECIFICATIONS                                | 101 |
| PRODUCT DIMENSIONS                                      | 102 |
| WIRING DIAGRAM  | 99  |
| SELECTION OF CAPACITOR - 5 STEP APPROACH                | 114 |
| PF TABLE  | 115 |
| MOTOR POWER FACTOR COMPENSATION                         | 118 |
| TRANSFORMER COMPENSATION                                | 120 |
| REACTIVE POWER COMPENSATION OF DG SETS                  | 121 |
| STANDARD AUTOMATIC POWER FACTOR CORRECTION PANELS       | 122 |
| CAPACITOR STEP SIZE SELECTION GUIDELINES IN APFC PANELS | 123 |
| FUSE SELECTION FOR APFC PANELS                          | 126 |
| MCCB SELECTION FOR APFC PANELS                          | 127 |
| CABLE SELECTION FOR CAPACITORS                          | 128 |
| THERMAL DESIGN OF APFC PANELS                           | 129 |

# Products of Power Quality

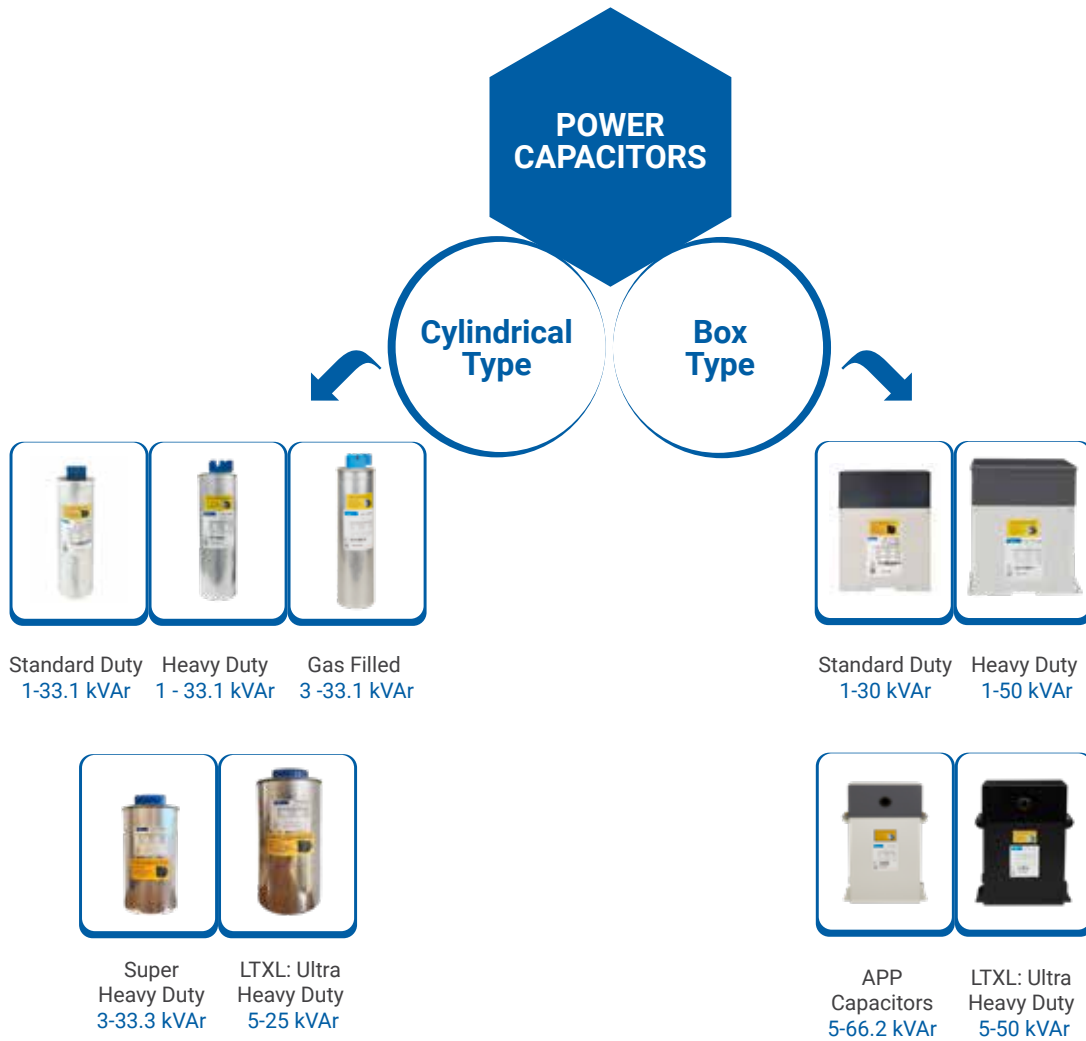

## HARMONIC FILTERING



# Products of Power Quality

## CAPACITOR SWITCHING



Thyristor Switching Modules  
10, 25 & 50 kVAr



Capacitor Duty Contactors -  
Type MO C  
3-100 kVAr

## POWER FACTOR CONTROLLER



etaULTRA Series  
APFC Controller  
Upto 16 Steps for Contactor Switching  
Upto 14 Steps for Thyristor Switching

Hybrid APFC Controller  
Upto 8 Steps for Contactor Switching  
& 8 Steps for Thyristor Switching



etaSMART Series  
APFC Controller  
Upto 16 Steps



# Power Factor Correction

## Principles of Power Factor Correction

A vast majority of electrical loads in low voltage industrial installations are inductive in nature. Typical examples are motors and transformers, which consume both active and reactive power. The active power is used by the load to meet its actual work requirements whereas reactive power is used by

the load to meet its magnetic field requirements. The reactive power (inductive) is always  $90^\circ$  lagging with respect to active power as shown in figure 1. Figure 2 & 3 show the flow of kW, kVAr and kVA in a network.

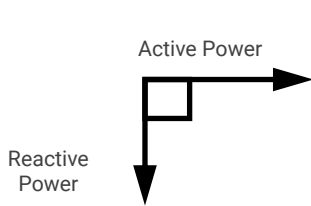

**Figure 1:**  
Phase relationship  
between Active and  
Reactive Power

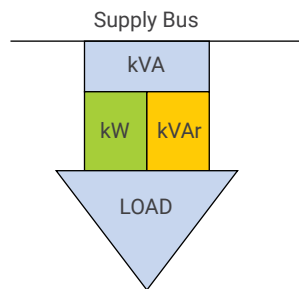

**Figure 2:**  
Network without  
Capacitor

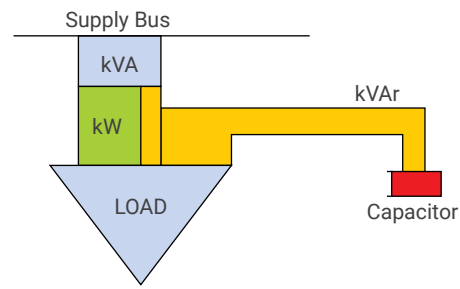

**Figure 3:**  
Network with Capacitor

Flow of active and reactive power always takes place in electrical installations. This means that the supply system has to be capable of supplying both active and reactive power. The supply of reactive power from the system results in reduced efficiency of the installation due to:

- › Increased current flow for a given load
- › Higher voltage drops in the system
- › Increase in losses of transformers, switchgear and cables
- › Higher kVA demand from supply system as given in figure 2
- › Higher electricity cost due to levy of penalties / loss of incentives

It is therefore necessary to reduce & manage the flow of reactive power to achieve higher efficiency of the electrical system and reduction in cost of electricity consumed.

The most cost effective method of reducing and managing reactive power is power factor improvement through Power Capacitors. The concept of reduction in kVA demand from the system is shown in figure 3.

## Benefits of Power Factor Correction

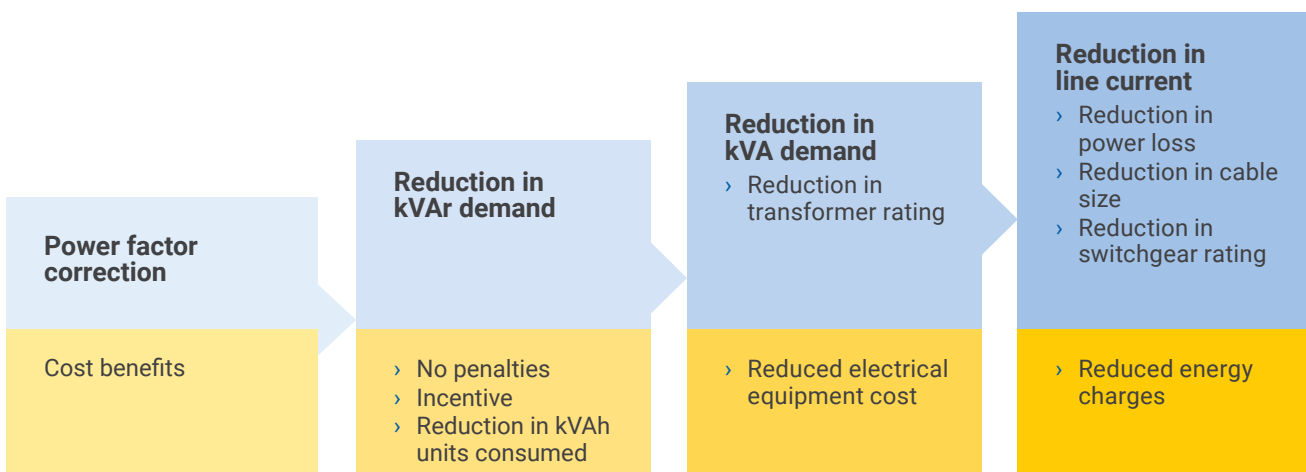

# Benefits of Using LT Capacitors Over HT Capacitors

Power factor compensation can be provided on either LT or HT side of the distribution transformer for the loads at LT side. Often compensation is done on the HT side as the electricity board measures power factor on HT side for penalty calculation. Also, HT capacitors involve low initial investment as compared to LT capacitors. However, compensation achieved by HT

capacitors does not provide the benefits offered by the use of LT capacitors, as discussed in this section.

Consider two cases with compensation provided on HT and LT side respectively as shown in figure 1 and 2.

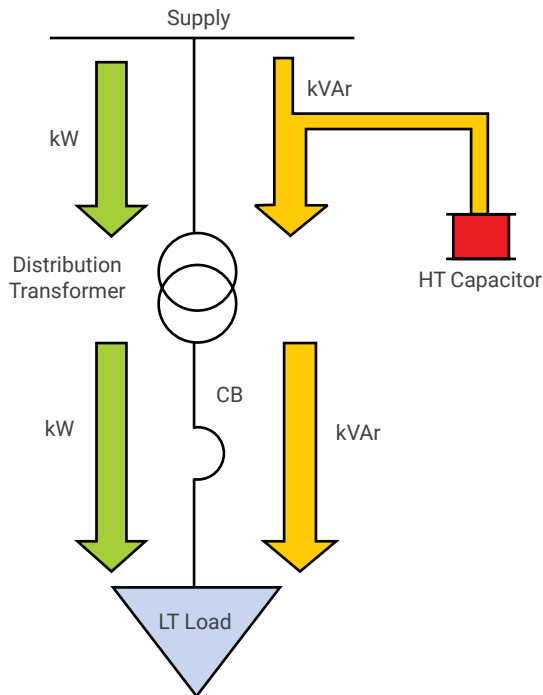

Fig 1: Compensation on HT Side

As seen in fig 1, with the capacitor connected on the HT side, the compensated reactive power flow through the transformer does not reduce and hence there is no change in current flow. Although the HT side power factor is improved, the LT

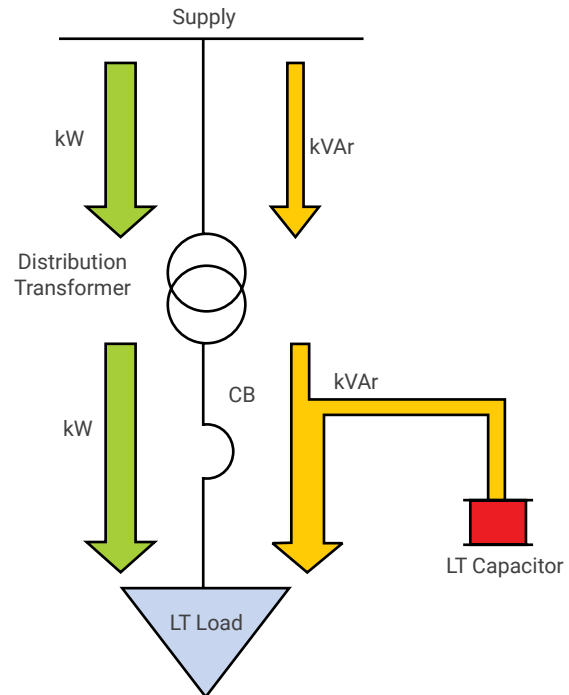

Fig 2: Compensation on LT Side

side power factor remains same. However, as seen in fig 2, connecting capacitor on LT side reduces the reactive power flow through the transformer and we get improved power factor and reduced current flow on both LT and HT sides.

## 1. Reduction in Transformer Copper Losses

Consider a load of 1200 kW connected to a transformer of 2000 kVA. The typical full-load copper losses in a 2000 kVA transformer are 25000 W.

When compensation is provided on HT side, operating power factor of the transformer is 0.75 (same as uncompensated), denoted by  $\cos\phi_1$ .

When compensation is provided on LT side, operating power factor of the transformer is 0.98 (compensated), denoted by  $\cos\phi_2$ .

$$\text{Power Saving} = W_f * K * \left( \frac{1}{\cos\phi_1} - \frac{1}{\cos\phi_2} \right)$$

where,

$$W_f = \text{Full Load Copper Losses} = 25000 \text{ W}$$

$$K = \frac{\text{Load in kW}}{\text{kVA rating of transformer}} = 0.6$$

|                                    |   |                         |   |                     |
|------------------------------------|---|-------------------------|---|---------------------|
| Power Saving (in W)                | = | 25000*0.6*(1/.75-1/.98) | = | 4694 W              |
| Monthly Energy Savings (in kWh)    | = | 4694 *24*30/1000        | = | 3380 kWh            |
| Typical Energy Charge (in Rs/kWh)  | = | Rs. 6 per kWh           |   |                     |
| <b>Monthly Cost Saving (in Rs)</b> | = | <b>6*3380</b>           | = | <b>Rs. 20278/-</b>  |
| <b>Yearly Cost Savings (in Rs)</b> | = | <b>20278*12</b>         | = | <b>Rs. 243330/-</b> |

Thus, LT compensation provides monthly savings of Rs. 20,278/- for a 2000 kVA transformer. Additionally, the operating temperature of the transformer is relatively less because of

reduced copper losses. Hence, apart from monetary benefits, LT compensation also ensures longer life of the transformer.

## 2. Capacity Release in Transformer

Consider a 2000 kVA transformer connected to a load.

**Cast 1:** When compensation is provided on HT side, operating PF of transformer = 0.75

Maximum load that can be connected = 2000\*0.75 = 1500 kW

**Cast 2:** When compensation is provided on LT side, operating PF of transformer = 0.98

Maximum Load that can be connected = 2000\*0.98 = 1960

kW Additional load that can be connected under the same transformer = 460 kW

LT compensation allows release of capacity of 460 kW with the same transformer. Thus, additional load can be easily connected to the system without any additional investments in new transformers.

## 3. Optimized Main Incomer Switchgear Rating

LT side capacitor, when connected after the main incomer reduces the current drawn by the same set of loads. Hence incomer switchgear rating can be optimized and the investment cost of the main incomer can be reduced.

Apart from those mentioned above, LT compensation also offers other advantages, such as

- › Maintenance of LT capacitors and panels is easier and does not require complex safety measures
- › Spares and accessories for the same are easily available and relatively cheaper

**Optimum solution:** Sense the PF from HT side and Capacitor switching on LT side near the load since electricity board meters are connected on HT side.

# Capacitor Technology

## MPP (Metalized Poly-propylene)

Capacitors are used in diverse applications, and hence different capacitor technologies are available. In low voltage applications, LT cylindrical capacitors which are made in accordance with metalized polypropylene technology, have proved to be the most appropriate and the most cost effective amongst all technologies. Depending on the nominal voltage of the capacitor, the thickness of the polypropylene film differs. Metallization is done on one side of the poly-propylene film.

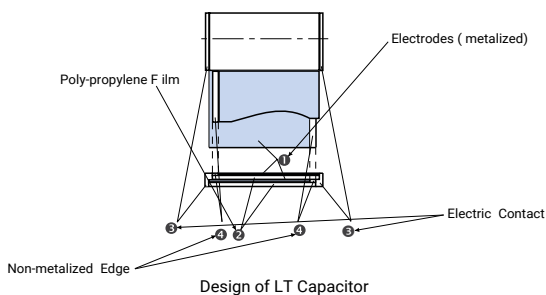

## Self - Healing

At the end of service life, or due to inadmissible electrical or thermal overload, an insulation breakdown may occur. This breakdown causes a small arc which evaporates the metal layer around the point of breakdown and hence re-establishes the insulation at the place of perforation. After electric breakdown, the capacitor can still be used. The decrease of capacitance caused by a self-healing process is less than 100 pF. The self-healing process lasts for a few microseconds only and the energy necessary for healing can be measured only by means of sensitive instruments.

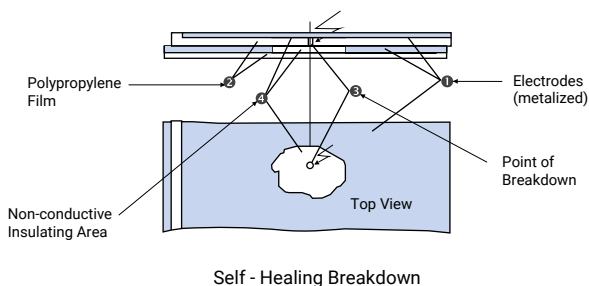

## Impregnation

Our LT-type capacitors are impregnated to safeguard from environmental influences and to guarantee reliable, long-term operation. Vacuum impregnation eliminates air and moisture, improves "self-healing" and reduces thermal resistance.

## Over Pressure Disconnecter (OPD)

At the end of service life or after several self-healing operations or due to inadmissible electrical or thermal overload, over pressure builds up and causes an expansion of the cover. Expansion over a certain limit causes the tear-off of the internal fuses. The active capacitor elements are thus cut-off from the source of supply. The pressure within the casing separates the breaking point so rapidly that no harmful arc occurs.

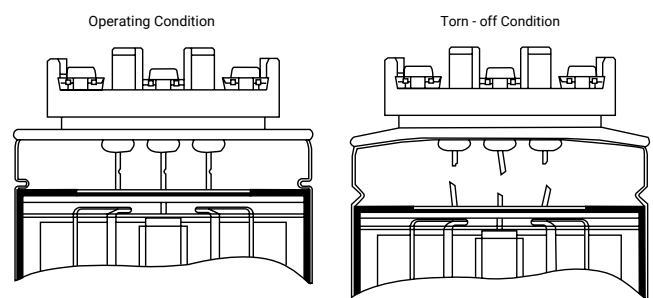

## Construction Details

Cylindrical capacitors consist of three units of single phase capacitors connected in delta kept inside an aluminium can. Technologically similar to cylindrical capacitors, box type capacitors consist of three or six single phase cylindrical capacitor cells. The individual cells are wired together and mounted on a steel frame. The steel frame together with the cells is housed in a common sheet steel casing. The enclosure is powder coated and is designed to protect the capacitor cells from dust and moisture. Ease of mounting is ensured by 4 drillings at the bottom of the container.

This design ensures highest safety by:

- › Self healing technology
- › Over pressure tear - off fuse
- › Robust steel container
- › Massive connection studs

MPP Capacitors are manufactured in the following types - Standard Duty, Standard Duty Prime, Heavy Duty, Super Heavy Duty & Ultra Heavy Duty. The Standard Duty capacitors are manufactured using standard thickness of dielectric material with heavy edge metalization. Standard Duty Prime, Heavy Duty, Super Heavy Duty & Ultra Heavy Duty capacitors are manufactured using thicker material and in lower width which increases current handling capacity as well as reduces temperature.

# Life of Power Capacitors

The life of a capacitor is influenced by the following three parameters:

- › Temperature
- › Voltage
- › Current

## Temperature

For a capacitor, the temperature depends upon the following parameters:

- › Ambient temperature at which capacitor is being operated
- › Amount of over current that flows through the capacitor
- › Power loss of the capacitor (dielectric power loss and resistive power loss)

The increase in temperature results in faster degradation of the dielectric. For every 10°C rise in temperature, the life of the capacitor is halved. Faster the degradation of the dielectric, lower will be the life of the capacitor.

Increase in temperature beyond a certain limit may result in expansion of impregnation and dielectric material. This may result in bulging of capacitors. In worst case, capacitor may even burst, if it does not have an over-pressure disconnecter.

The capacitor must thus be operated at rated ambient temperature for a long operating life.

Capacitors are classified in temperature categories, each category being specified by a number followed by a letter. The number represents the lowest ambient air temperature at which the capacitor may operate. The letters represent upper limits of temperature variation ranges.

Letter symbols for upper limit of temperature range as per IEC 60831 are as follows :

| Symbol | Ambient Temperature (OC) |                                 |        |
|--------|--------------------------|---------------------------------|--------|
|        | Maximum                  | Highest mean over any period of |        |
|        |                          | 24 h                            | 1 year |
| A      | 40                       | 30                              | 20     |
| B      | 45                       | 35                              | 25     |
| C      | 50                       | 40                              | 30     |
| D      | 55                       | 45                              | 35     |

## Voltage

The increase in system voltage has the following effects on the capacitor:

- › **Dielectric degradation**  
If the voltage increases beyond a certain limit, the dielectric material will breakdown. This critical voltage is called the dielectric breakdown voltage. Breakdown can result in an internal short circuit causing the capacitor to fail permanently.
- › **Increase in current flow through the capacitor**  
As capacitors are linear in nature, with increase in voltage,

the capacitor current also increases because  $X_C$  remains constant ( $I_C = V/X_C$ ). This results in overloading of the capacitor, which may reduce the life of the capacitor. Over voltage limits of the capacitors are +10% for 8 hrs in 24 hrs, +15% for 30 min in 24h, +20% for 5 min in 24 hrs and +30% for 1 min in 24 hrs.

## Current

The parameters that are related to current, which affect the life of the capacitor are:

- › **Inrush current**  
Whenever the capacitor is switched on, it draws a huge inrush current which goes up to levels even greater than 100 times the capacitor rated current. Frequent switching of the capacitor without proper inrush current limiting devices will affect the life of the capacitor as it is heavily stressed during each switching operation. Switching frequency and amplitude of inrush current thus influences the life of the capacitor.
- › **Over-load current**  
Continuous overload of capacitor is mainly because of harmonics and continuous over voltage. Overloading results in local hot spots and may lead to an internal short circuit.  
  
To conclude, all the above parameters should be within the rated value in order to exploit the maximum life of the capacitor.

# Capacitor Power Loss Calculation

A capacitor is a passive device which has two conductors separated by a dielectric of infinite resistance, ideally. Hence, it should offer only capacitive reactance, with zero resistance and zero inductance values. But practically, the dielectric of the capacitor will offer a finite resistance along with the capacitance. This finite resistance is called as **Equivalent Series Resistance (ESR)**, and its equivalent circuit can be represented as below:

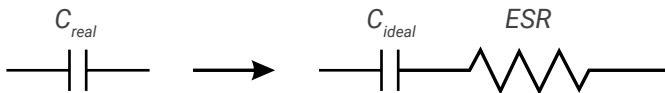

The ESR in the capacitor causes the leakage current to flow through the dielectric of the capacitor. This results in real power loss ( $I^2 \times ESR$ ) called as dielectric loss. Higher the ESR, higher is the power loss, and hence the heat generated by the capacitor is also more. The heat generated should be dissipated properly; otherwise it may result in significant temperature rise. A good quality capacitor has very low ESR value.

In a lossless (ideal) capacitor, the current leads the voltage exactly by  $90^\circ$ . But there is always a small shortfall in the lead angle from  $90^\circ$ , because of the dielectric loss. The difference in angle is called loss angle ( $\delta$ ). The following diagram represents loss angle ( $\delta$ ) in the impedance plane.

The tangent of the loss angle (loss tangent) is defined as the ratio of the capacitor's equivalent series resistance (ESR) to the capacitive reactance ( $X_c$ ).

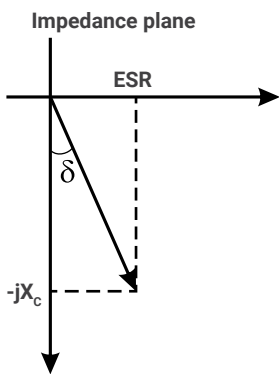

$$\tan \delta = \frac{ESR}{[X_c]} \rightarrow \text{(Eq 1)}$$

$$\begin{aligned} \text{Power loss} &= I^2 \times ESR \\ &= (\omega CV) \times (\omega CV) \times ESR \text{ where, } \omega = 2\pi f \\ &= (\omega C) \times (\omega CV^2) \times ESR \\ &= (\omega C) \times Q \times ESR \\ &= Q \times ESR / X_c \end{aligned}$$

$$\text{Power loss} = Q \tan \delta \text{ [from Eq 1]}$$

Where, Q is the reactive power rating of the capacitor (in VAR).

Typically, for good quality power capacitors,  $\tan \delta$  value is less than 0.0002. Power loss of any capacitor can be computed if  $\tan \delta$  value is known as explained in the example below:

For a 10 kVAR capacitor, consider the value of  $\tan \delta$  as 0.0002.

$$\begin{aligned} \text{Total watt loss} &= 10 \times 1000 \times 0.0002 \\ &= 2 \text{ watts} \end{aligned}$$

$$\begin{aligned} \text{Per kVAR power loss} &= \text{Total watt loss} / \text{kVAR} \\ &= 2/10 \\ &= 0.2 \text{ watts per kVAR} \end{aligned}$$



Normally, the  $\tan \delta$  value is available in the routine test certificate of the power capacitor.

The life of a power capacitor is largely dependent upon temperature. Hence, it is a good practice to do the thermal design of APFC panel after computing the capacitor power loss.

# Discharge Resistors

Typically, power factor correction capacitors are fitted with discharge resistors connected directly across the terminals (two resistors between three phases). These resistors are mandatory safety requirement recommended by the capacitor standards, to discharge the residual voltage that remains in the capacitor, once it is switched off.

As per IEC 60831 (MPP capacitors) and IEC 60931 (APP capacitors) the capacitor should discharge to 75 V or below within 3 min as soon as the capacitor is switched off. This is to protect human beings from the risk of electric shock and also for safe re-switching of the same capacitor in APFC panel. As a general practice, discharge resistors bring the voltage to below 50 V in 1 min, which is safer.



**Cylindrical capacitor's terminal block with discharge resistor**

If the capacitor is re-switched without discharging sufficiently, there is a possibility that the voltage difference across the contactor may shoot up to 1000 V. More over, this results in very high peak inrush current as the rate of change of voltage is very high ( $I_c = C \, dV/dt$ ). Such frequent switchings reduce the life of the capacitor and/or the contactor, and may cause premature failures. Hence while re-switching the capacitor (either in manual mode or auto mode) it is mandatory to discharge the capacitor to its 10% rated voltage.

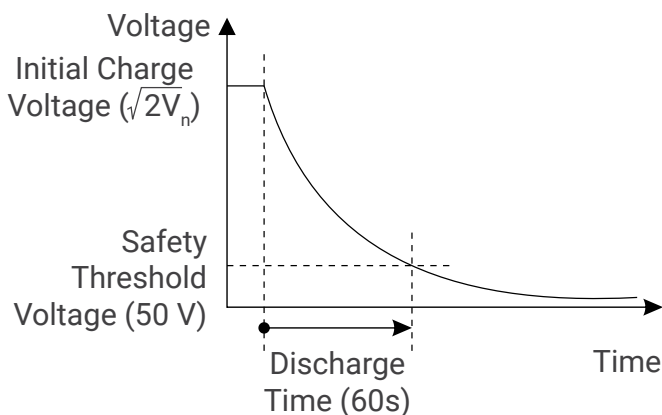

In order to ensure the sufficient discharge, it should be ensured that the capacitor is re-switched only after 45 to 60 seconds. This time delay (for re-switching the same capacitor bank) can be set in APFC relay. In case, any application demands frequent switching of capacitors by contactors, time delay can be reduced by faster discharge of the residual voltage. Faster discharging can be achieved by replacing the existing resistors with new resistors of lesser resistance.

Formula to calculate the resistance is:

$$R \leq \frac{t}{3C \times \log \left( \frac{\sqrt{2}V_n}{V_r} \right)}$$

Where,

R = Discharge resistance value in  $\Omega$

t = time for discharge from  $\sqrt{2}V_n$  (ie., peak voltage) to  $V_r$  (50 V), in seconds

C = Rated capacitance per phase, in  $\mu\text{F}$

$V_n$  = Rated voltage of capacitor unit, in V

$V_r$  = Permissible residual voltage, in V

The above formula is valid for resistors assembly in the delta connected capacitor (two resistors between three terminals), as shown in the figure.

However, opting for lower resistance for faster discharge will increase the power loss. At the same time, appropriate power rating (wattage) of the resistor should be chosen to ensure sufficient current carrying capacity of the resistor.

$$\text{Power rating of the resistor (in watts)} = 1.3 v_n I = \frac{1.3 \times V_n^2}{(2 \pi f C)}$$

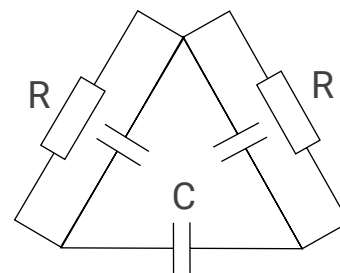

Here, the resistor should withstand the initial peak discharge current even if the capacitor is switched off at the instant of 30% over voltage.

# Voltage Selection of Power Capacitors

The name plate of a capacitor usually has three kVAR ratings at three different voltages. kVAR rating of the capacitor is directly proportional to square of the applied voltage.

This is evident from the below formula:

$$\text{kVAR} = \frac{V^2}{X_c}$$

As capacitance (C in uF) remains same for a capacitor,  $X_c$  will remain constant.

For example, if a capacitor is rated for 30 kVAR at 480 V, and if the applied voltage is 440 V, the kVAR output can be calculated as follows:

$$\begin{aligned} \text{kVAR output} &= \text{Rated kVAR} \times \frac{(\text{Applied voltage})^2}{(\text{Rated voltage})^2} \\ &= 30 \times \frac{(440)^2}{(480)^2} \\ &= 25.2 \text{ kVAR at } 440 \text{ V} \end{aligned}$$

Similarly, if we apply 500 V for the same capacitor, the kVAR output will be 32.5 kVAR. In this case, we are applying voltage more than the rated value and the capacitor will deliver kVAR output more than its rated value. Hence the life of the capacitor may reduce drastically, because of over-voltage and over-current.

To summarize, the product label of a capacitor (for e.g. 30 kVAR, 480 V) has the following details as shown above.

## Heavy Duty 30 kVAR Power Capacitor

| Un    | 50 Hz     | In     |
|-------|-----------|--------|
| 480 V | 30.0 kVAR | 36.1 A |
| 440 V | 25.2 kVAR | 33.1 A |
| 415 V | 22.4 kVAR | 31.2 A |

|               |               |          |      |     |
|---------------|---------------|----------|------|-----|
| 3X138 $\mu$ F | 3 Phase       | D        | SH   | MPP |
| -40/D         | Ui 3/kV       | Case Max | 65°C |     |
| NPCB          | Non Flammable |          | 55°C |     |

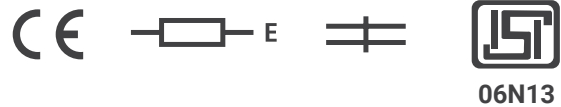

**MADE IN INDIA**  
**DISCHARGE CAPACITOR BEFORE HANDLING**

Capacitor label

Similarly, for 25 kVAR and 440 V capacitor, the name plate contains the respective kVAR ratings and current ratings at 440 V, 415 V and 400 V.

## Selection of Capacitors When System Voltage is 415 V

Before deciding the voltage of the capacitor, it is important to understand the percentage impedance of the transformer (% Z). The percentage impedance is the voltage drop on full load due to the winding resistance and leakage reactance of the transformer. This is expressed as a percentage of the rated voltage. For example, if the secondary of the transformer is rated for 433 V and %Z is 4%, the voltage available at the load end, during full load conditions, would be 415 V only. When the load decreases, the voltage drop decreases and hence the voltage at the load end increases. During no-load conditions, the voltage can reach a maximum of 433 V.

If a capacitor is selected with 415 V (in the above case), it would be subjected to over-voltage during partial load or no-load conditions. This would impact the capacitor life drastically. For a normal capacitor, following are the over-voltage limits permitted as per IEC:

- › 10% over-voltage for 8 hours in every 24 hours
- › 15% over-voltage for 30 minutes in every 24 hours
- › 20% over-voltage for 5 minutes in every 24 hours
- › 30% over-voltage for 1 minute in every 24 hours

Hence, the capacitor should be rated for 440 V, even though the voltage at the load end is measured as 415 V. In general, it is a better practice to select capacitor voltage greater than the rated secondary voltage of the transformer and hence, avoid prolonged over-voltage conditions.

### HAZARD OF ELECTRICAL SHOCK

Wait 5 minutes after isolating supply before handling  
**Failure to follow these instructions**

# Standard Duty Capacitors



Lauritz Knudsen Electrical & Automation (E&A) Standard Duty Capacitors are metalized polypropylene capacitors from 1 - 33.1 kVAR in cylindrical configuration and 1-33.1 kVAR in box type configuration. These capacitors come with a stacked winding and are impregnated with a biodegradable soft resin. These capacitors are self healing type. The Capacitors come with an over pressure disconnecter and finger proof terminals. They can be used to provide effective power factor correction in industrial and semi industrial applications.

For Selection and Application details please refer page no.112

## Technical Details

|   | Standard Duty  |  |
|---|--|--|
|   | Box  | Cylindrical  |
| <b>Series</b>                           | LTBCF (1 to 6 kVAR) and<br>LTBCD (7.5 kVAR and above)  | LTCCF (1 to 6 kVAR)<br>LTCCD (7.5 kVAR above)  |
| <b>Range</b>                            | 1 - 33.1 kVAR  | 1 - 33.1 kVAR  |
| <b>Standards</b>                        | IS 13340-2012, IS 13341-1992,<br>IEC 60831-1+2   | IS 13340-2012, IS 13341-1992,<br>IEC 60831-1+2   |
| <b>Rated Frequency</b>                  | 50 Hz  | 50 Hz  |
| <b>Rated Voltage</b>                    | 440 / 480 / 525 V  | 440 / 480 / 525 V  |
| <b>Over Voltage</b>                     | +10% (8h/24h), +15% (30m/24h),<br>+20% (5m/24hrs), +30% (1m/24hrs)   | +10% (8h/24h), +15% (30m/24h),<br>+20% (5m/24hrs), +30% (1m/24hrs)   |
| <b>Overcurrent</b>                      | 1.5 x In   | 1.5 x In   |
| <b>Peak Inrush Current</b>              | 200 x In   | 200 x In   |
| <b>Operating Losses (Dielectric)</b>    | ≤ 0.2 W / kVAR   | ≤ 0.2 W / kVAR   |
| <b>Operating Losses (Total)</b>         | ≤ 0.45 W / kVAR  | ≤ 0.45 W / kVAR  |
| <b>Tolerance on Capacitance</b>         | -5 / +10% as per IS  | -5 / +10% as per IS  |
| <b>Test Voltage (Terminal-Terminal)</b> | 2.15 Times rated voltage for 10 sec  | 2.15 Times rated voltage for 10 sec  |
| <b>Test Voltage (Terminal-Casing)</b>   | 3 kV (AC) for 1 minute   | 3 kV (AC) for 1 minute   |
| <b>Degree of Protection</b>             | IP20, Indoor mounting  | IP20, Indoor mounting  |
| <b>Ambient Temperature</b>              | -25 / D<br>Max temperature = +55°C<br>Max mean temperature (24 h) = +45°C<br>Max mean temperature (1 year) = +35°C | -25 / D<br>Max temperature = +55°C<br>Max mean temperature (24 h) = +45°C<br>Max mean temperature (1 year) = +35°C |
| <b>Cooling</b>                          | Natural or forced air cooling  | Natural or forced air cooling  |
| <b>Permissible Relative Humidity</b>    | Max 95%  | Max 95%  |
| <b>Maximum Operating Altitude</b>       | 4000 m above sea level   | 4000 m above sea level   |
| <b>Mounting</b>                         | Upright  | Upright  |
| <b>Safety Features</b>                  | Overpressure disconnecter, Self-healing,<br>Finger-proof terminals   | Overpressure disconnecter, Self-healing,<br>Finger-proof terminals   |
| <b>Impregnation</b>                     | Non-PCB biodegradable resin  | Non-PCB biodegradable resin  |
| <b>Casing</b>                           | MS Sheet metal   | Aluminum extruded can  |
| <b>Dielectric Composition</b>           | Metalized polypropylene  | Metalized polypropylene  |
| <b>Terminals</b>                        | Wire length 150mm (1 - 6 kVAR)<br>Ceramic bushing (7.5 kVAR and above)   | Wire length 150mm (1 - 6 kVAR)<br>Finger-proof clampite (7.5 kVAR and above)                                       |
| <b>Discharge Resistors / Time</b>       | Discharge resistors fitted,<br>Standard discharge time 60 seconds  | Discharge resistors fitted,<br>Standard discharge time 60 seconds  |
| <b>Switching Operations (maximum)</b>   | 5000 Switchings per year   | 5000 Switchings per year   |
| <b>Life*</b>                            | 1,00,000 hrs   | 1,00,000 hrs   |

\*at standard operating conditions

# Standard Duty Capacitors - Overall Dimensions

## Cylindrical Type

### 1 kVAR to 6 kVAR

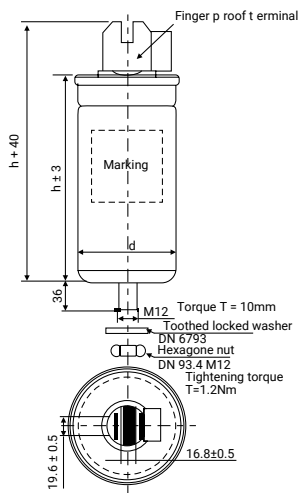

### 7.5 kVAR to 25 kVAR

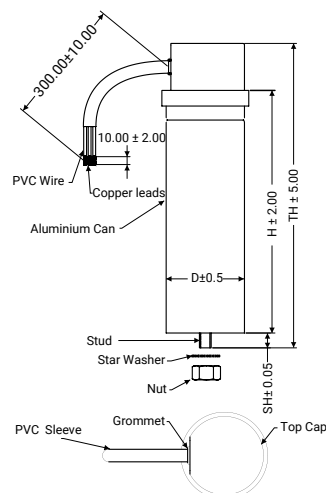

| Sr. No. | Voltage | Power Rating (kVAR) |      | Capacitance (µF) | Rated Current (A) | Dimensions in mm |      | Cat. No.   |
|---------|---------|---------------------|------|------------------|-------------------|------------------|------|------------|
|         |         | 50Hz                | 60Hz |                  |                   | H                | D    |            |
| 1       | 440 V   | 1                   | 1    | 16.44            | 1.31              | 105              | 50   | LTCCF301B2 |
| 2       | 440 V   | 2                   | 2    | 32.88            | 2.62              | 125              | 50   | LTCCF302B2 |
| 3       | 440 V   | 3                   | 4    | 49.32            | 3.94              | 128              | 50   | LTCCF303B2 |
| 4       | 440 V   | 4                   | 5    | 65.77            | 5.25              | 150              | 63.5 | LTCCF304B2 |
| 5       | 440 V   | 5                   | 6    | 82.21            | 6.56              | 150              | 63.5 | LTCCF305B2 |
| 6       | 440 V   | 6                   | 7    | 98.65            | 7.87              | 185              | 63.5 | LTCCF306B2 |
| 7       | 440 V   | 7.5                 | 9    | 123.31           | 9.84              | 195              | 75   | LTCCD307B2 |
| 8       | 440 V   | 8.33                | 10   | 136.96           | 10.93             | 195              | 75   | LTCCD308B2 |
| 9       | 440 V   | 10                  | 12   | 164.42           | 13.12             | 195              | 85   | LTCCD310B2 |
| 10      | 440 V   | 12.5                | 15   | 205.52           | 16.40             | 270              | 85   | LTCCD312B2 |
| 11      | 440 V   | 15                  | 18   | 246.62           | 19.68             | 270              | 85   | LTCCD315B2 |
| 12      | 440 V   | 20                  | 24   | 328.83           | 26.24             | 345              | 85   | LTCCD320B2 |
| 13      | 440 V   | 25                  | 30   | 411.04           | 32.8              | 345              | 90   | LTCCD325B2 |
| 14      | 480 V   | 1.2                 | 1.4  | 8.28             | 1.44              | 105              | 50   | LTCCF301C2 |
| 15      | 480 V   | 2.2                 | 2.6  | 15.18            | 2.64              | 125              | 50   | LTCCF302C2 |
| 16      | 480 V   | 3.3                 | 4.0  | 22.77            | 3.96              | 128              | 50   | LTCCF303C2 |
| 17      | 480 V   | 4.4                 | 5.3  | 30.36            | 5.28              | 150              | 63.5 | LTCCF304C2 |
| 18      | 480 V   | 5.5                 | 6.6  | 37.95            | 6.6               | 150              | 63.5 | LTCCF305C2 |
| 19      | 480 V   | 11.1                | 13.3 | 76.59            | 13.32             | 203              | 85   | LTCCD311C2 |
| 20      | 480 V   | 13.8                | 16.6 | 95.22            | 16.56             | 278              | 75   | LTCCD313C2 |
| 21      | 480 V   | 16.6                | 19.9 | 114.54           | 19.92             | 278              | 85   | LTCCD316C2 |
| 22      | 480 V   | 22.1                | 26.5 | 152.49           | 26.52             | 278              | 90   | LTCCD322C2 |
| 23      | 480 V   | 27.7                | 33.2 | 191.13           | 33.24             | 281              | 100  | LTCCD327C2 |
| 24      | 525 V   | 1.3                 | 1.6  | 7.51             | 1.43              | 125              | 50   | LTCCF301M2 |
| 25      | 525 V   | 2.6                 | 3.1  | 15.02            | 2.86              | 150              | 50   | LTCCF302M2 |
| 26      | 525 V   | 3.9                 | 4.7  | 22.52            | 4.29              | 150              | 63.5 | LTCCF303M2 |
| 27      | 525 V   | 5.3                 | 6.4  | 30.61            | 5.83              | 150              | 63.5 | LTCCF305M2 |
| 28      | 525 V   | 6.6                 | 7.9  | 38.12            | 7.26              | 155              | 75   | LTCCF306M2 |
| 29      | 525 V   | 13.2                | 15.8 | 76.23            | 14.52             | 278              | 75   | LTCCD313M2 |
| 30      | 525 V   | 16.6                | 19.9 | 95.87            | 18.26             | 278              | 85   | LTCCD316M2 |
| 31      | 525 V   | 20                  | 24   | 23.9             | 21.99             | 278              | 90   | LTCCD320M2 |
| 32      | 525 V   | 26.5                | 31.8 | 153.04           | 29.15             | 281              | 100  | LTCCD326M2 |
| 33      | 525 V   | 33.1                | 39.7 | 191.15           | 36.41             | 288              | 116  | LTCCD333M2 |

# Standard Duty Capacitors - Overall Dimensions

## Box Type

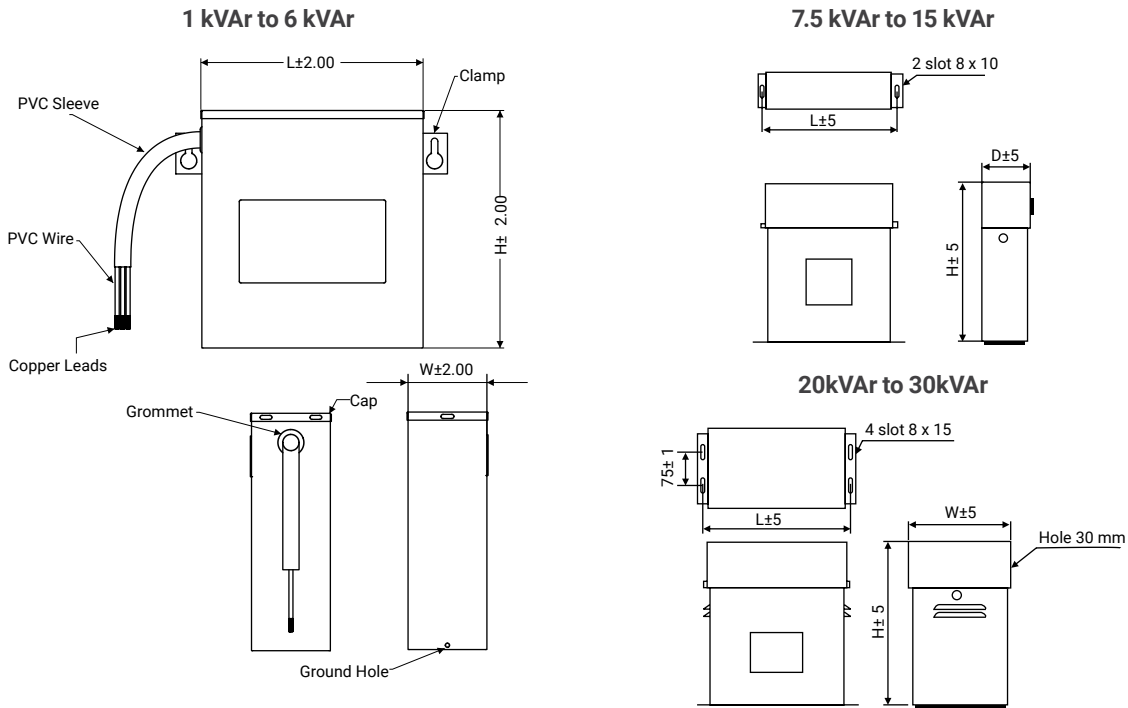

| Sr. No. | Voltage | Power Rating (kVAR) |      | Capacitance (µF) | Rated Current (A) | Dimensions in mm |     |     | Cat. No.   |
|---------|---------|---------------------|------|------------------|-------------------|------------------|-----|-----|------------|
|         |         | 50Hz                | 60Hz |                  |                   | L                | W   | H   |            |
| 1       | 440 V   | 1                   | 1    | 16.44            | 1.31              | 108              | 38  | 112 | LTBCF301B2 |
| 2       | 440 V   | 2                   | 2    | 32.88            | 2.62              | 108              | 38  | 112 | LTBCF302B2 |
| 3       | 440 V   | 3                   | 4    | 49.32            | 3.94              | 137              | 48  | 112 | LTBCF303B2 |
| 4       | 440 V   | 4                   | 5    | 65.77            | 5.25              | 137              | 48  | 112 | LTBCF304B2 |
| 5       | 440 V   | 5                   | 6    | 82.21            | 6.56              | 137              | 48  | 112 | LTBCF305B2 |
| 6       | 440 V   | 6                   | 7    | 98.65            | 7.87              | 137              | 48  | 112 | LTBCF306B2 |
| 7       | 440 V   | 7.5                 | 9    | 123.31           | 9.84              | 240              | 80  | 300 | LTBCD307B2 |
| 8       | 440 V   | 8.33                | 10   | 136.96           | 10.93             | 240              | 80  | 300 | LTBCD308B2 |
| 9       | 440 V   | 10                  | 12   | 164.42           | 13.12             | 240              | 80  | 300 | LTBCD310B2 |
| 10      | 440 V   | 12.5                | 15   | 205.52           | 16.40             | 240              | 80  | 300 | LTBCD312B2 |
| 11      | 440 V   | 15                  | 18   | 246.62           | 19.68             | 240              | 80  | 300 | LTBCD315B2 |
| 12      | 440 V   | 20                  | 24   | 328.83           | 26.24             | 240              | 160 | 300 | LTBCD320B2 |
| 13      | 440 V   | 25                  | 30   | 411.04           | 32.80             | 240              | 160 | 300 | LTBCD325B2 |
| 14      | 440 V   | 30                  | 36   | 493.25           | 39.37             | 240              | 160 | 300 | LTBCD330B2 |
| 15      | 480 V   | 11.1                | 13.3 | 76.59            | 13.32             | 225              | 80  | 300 | LTBCD311C2 |
| 16      | 480 V   | 13.8                | 16.6 | 95.22            | 16.56             | 225              | 80  | 300 | LTBCD313C2 |
| 17      | 480 V   | 16.6                | 19.9 | 114.54           | 19.92             | 225              | 80  | 300 | LTBCD316C2 |
| 18      | 480 V   | 22.1                | 26.5 | 152.49           | 26.52             | 225              | 160 | 300 | LTBCD322C2 |
| 19      | 480 V   | 27.7                | 33.2 | 191.13           | 33.24             | 225              | 160 | 300 | LTBCD327C2 |
| 20      | 525 V   | 13.2                | 15.8 | 76.23            | 14.52             | 225              | 80  | 300 | LTBCD313M2 |
| 21      | 525 V   | 16.6                | 19.9 | 95.87            | 18.26             | 225              | 80  | 300 | LTBCD316M2 |
| 22      | 525 V   | 20                  | 24   | 23.9             | 21.99             | 225              | 90  | 278 | LTBCD320M2 |
| 23      | 525 V   | 26.5                | 31.8 | 153.04           | 29.15             | 225              | 160 | 300 | LTBCD326M2 |
| 24      | 525 V   | 33.1                | 39.7 | 191.15           | 36.41             | 225              | 160 | 300 | LTBCD333M2 |

# Heavy Duty Capacitors



E&A's Heavy Duty Capacitors are metalized polypropylene capacitors available from 1-33.1 kVAR in cylindrical and from 1-50 kVAR in box type construction. These capacitors have an inrush current withstand of 300 In and an overload withstand capacity of 1.8 In. These capacitors have all the features of standard capacitors like over pressure disconnecter and self healing.

For Selection and Application details please refer page no.112

|   | Heavy Duty   |  |
|---|--|--|
|   | Box  | Cylindrical  |
| <b>Series</b>                           | LTBCH  | LTCCH  |
| <b>Range</b>                            | 1 - 50 kVAR  | 1 - 33.1 kVAR  |
| <b>Standards</b>                        | IS 13340-1993, IS 13341-1992, IEC 60831-1+2  | IS 13340-1993, IS 13341-1992, IEC 60831-1+2  |
| <b>Rated Frequency</b>                  | 50 Hz  | 50 Hz  |
| <b>Rated Voltage</b>                    | 440 / 480 / 525 V  | 440 / 480 / 525 V  |
| <b>Over Voltage</b>                     | +10% (8h/24h), +15% (30m/24h), +20% (5m/24hrs), +30% (1m/24hrs)  | +10% (8h/24h), +15% (30m/24h), +20% (5m/24hrs), +30% (1m/24hrs)  |
| <b>Over current</b>                     | 1.8 x In   | 1.8 x In   |
| <b>Peak Inrush Current</b>              | 300 x In   | 250 x In   |
| <b>Operating Losses (Dielectric)</b>    | ≤ 0.2 W / kVAR   | ≤ 0.2 W / kVAR   |
| <b>Operating Losses (Total)</b>         | ≤ 0.45 W / kVAR  | ≤ 0.45 W / kVAR  |
| <b>Tolerance on Capacitance</b>         | -5 / +10% as per IS  | -5 / +10% as per IS  |
| <b>Test Voltage (Terminal-Terminal)</b> | 2.15 times rated voltage for 10 sec  | 2.15 times rated voltage for 10 sec  |
| <b>Test Voltage (Terminal-Casing)</b>   | 3 kV (AC) for 1 minute   | 3 kV (AC) for 1 minute   |
| <b>Degree of Protection</b>             | IP20, indoor mounting  | IP20, indoor mounting  |
| <b>Ambient Temperature</b>              | -25 / D<br>Max temperature = +55°C<br>Max mean temperature (24 h) = +45°C<br>Max mean temperature (1 year) = +35°C | -40 / D<br>Max temperature = +55°C<br>Max mean temperature (24 h) = +45°C<br>Max mean temperature (1 year) = +35°C |
| <b>Cooling</b>                          | Natural or forced air cooling  | Natural or forced air cooling  |
| <b>Permissible Relative Humidity</b>    | Max 95%  | Max 95%  |
| <b>Maximum Operating Altitude</b>       | 4000 m above sea level   | 4000 m above sea level   |
| <b>Mounting</b>                         | Upright  | Upright  |
| <b>Safety Features</b>                  | Overpressure disconnecter, Finger-proof terminals, Self-healing  | Overpressure disconnecter, Finger-proof terminals, Self-healing  |
| <b>Impregnation</b>                     | Non PCB biodegradable resin  | Non PCB biodegradable resin  |
| <b>Casing</b>                           | MS Sheet metal   | Aluminum extruded can  |
| <b>Dielectric Composition</b>           | Metalized polypropylene  | Metalized polypropylene  |
| <b>Terminals</b>                        | Ceramic bushing  | Fast-on terminals upto 5 kVAR<br>Finger-proof clampite upto 33.1 kVAR  |
| <b>Discharge Resistors / Time</b>       | Discharge resistors fitted, Standard discharge time 60 seconds   | Discharge resistors fitted, Standard discharge time 60 seconds   |
| <b>Switching Operations (maximum)</b>   | 8000 Switchings per year   | 7500 Switchings per year   |
| <b>Life*</b>                            | 1,50,000 hrs   | 1,30,000 hrs   |

\*at standard operating conditions

# Heavy Duty Capacitors - Overall Dimensions

## Cylindrical Type

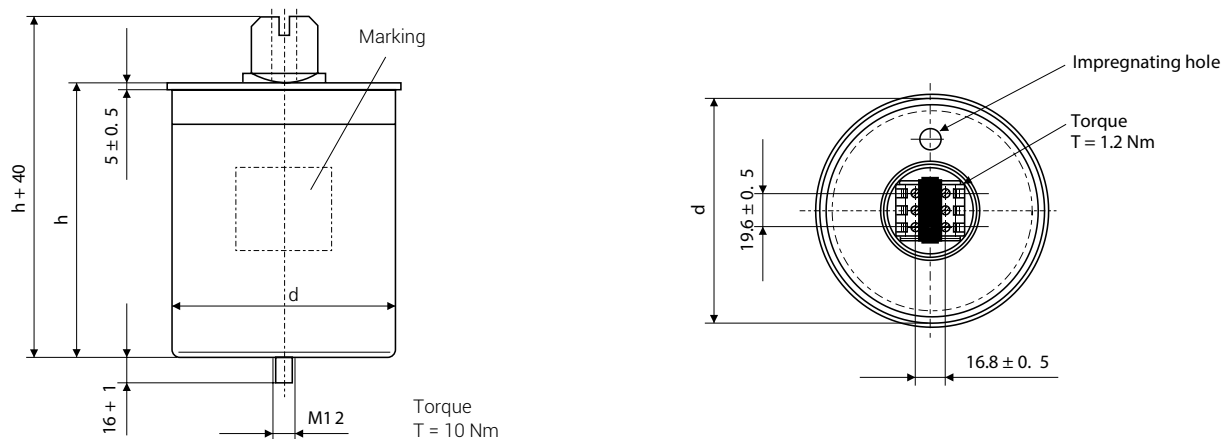

| Sr. No. | Voltage | Power Rating (kVar) |       | Capacitance ( $\mu$ F) | Rated Current (A) | Dimensions in mm |    | Cat. No.   |
|---------|---------|---------------------|-------|------------------------|-------------------|------------------|----|------------|
|         |         | 50Hz                | 60Hz  |                        |                   | H                | D  |            |
| 1       | 440 V   | 1                   | 1.2   | 16.44                  | 1.30              | 75               | 50 | LTCCH301B2 |
| 2       | 440 V   | 2                   | 2.4   | 32.88                  | 2.60              | 112              | 50 | LTCCH302B2 |
| 3       | 440 V   | 3                   | 3.6   | 49.32                  | 3.90              | 112              | 55 | LTCCH303B2 |
| 4       | 440 V   | 4                   | 4.8   | 65.77                  | 5.20              | 137              | 55 | LTCCH304B2 |
| 5       | 440 V   | 5                   | 6     | 82.21                  | 6.60              | 147              | 55 | LTCCH305B2 |
| 6       | 440 V   | 7.5                 | 9     | 123.31                 | 9.80              | 160              | 75 | LTCCH307B2 |
| 7       | 440 V   | 10                  | 12    | 164.42                 | 13.10             | 197              | 75 | LTCCH310B2 |
| 8       | 440 V   | 12.5                | 15    | 205.52                 | 16.40             | 197              | 75 | LTCCH312B2 |
| 9       | 440 V   | 15                  | 18    | 246.62                 | 19.70             | 197              | 85 | LTCCH315B2 |
| 10      | 440 V   | 20                  | 24    | 328.83                 | 26.20             | 270              | 75 | LTCCH320B2 |
| 11      | 440 V   | 25                  | 30    | 411.04                 | 32.80             | 270              | 85 | LTCCH325B2 |
| 12      | 440 V   | 28.1                | 33.7  | 462                    | 36.87             | 348              | 85 | LTCCH328B2 |
| 13      | 440 V   | 30                  | 36    | 493.25                 | 39.40             | 353              | 85 | LTCCH330B2 |
| 14      | 480 V   | 5.5                 | 6.6   | 75.99                  | 6.60              | 136              | 63 | LTCCH305C2 |
| 15      | 480 V   | 11.1                | 13.32 | 153.35                 | 13.40             | 197              | 75 | LTCCH311C2 |
| 16      | 480 V   | 13.2                | 16.56 | 190.65                 | 16.60             | 197              | 75 | LTCCH313C2 |
| 17      | 480 V   | 16.6                | 19.92 | 229.34                 | 20.00             | 197              | 85 | LTCCH316C2 |
| 18      | 480 V   | 22.1                | 26.52 | 305.32                 | 26.60             | 270              | 85 | LTCCH322C2 |
| 19      | 480 V   | 27.7                | 33.24 | 382.69                 | 33.30             | 270              | 90 | LTCCH327C2 |
| 20      | 525 V   | 6.6                 | 7.92  | 76.22                  | 7.30              | 160              | 75 | LTCCH306M2 |
| 21      | 525 V   | 13.2                | 15.84 | 152.44                 | 14.50             | 197              | 85 | LTCCH313M2 |
| 22      | 525 V   | 16.6                | 19.92 | 191.71                 | 18.30             | 270              | 75 | LTCCH316M2 |
| 23      | 525 V   | 20                  | 24    | 230.97                 | 22.00             | 270              | 85 | LTCCH320M2 |
| 24      | 525 V   | 26.5                | 31.8  | 306.04                 | 29.10             | 270              | 90 | LTCCH326M2 |
| 25      | 525 V   | 30                  | 36    | 346.46                 | 33.00             | 353              | 85 | LTCCH330M2 |
| 26      | 525 V   | 33.1                | 39.72 | 382.26                 | 36.40             | 353              | 85 | LTCCH333M2 |

## Heavy Duty Capacitors - Overall Dimensions

### Box Type

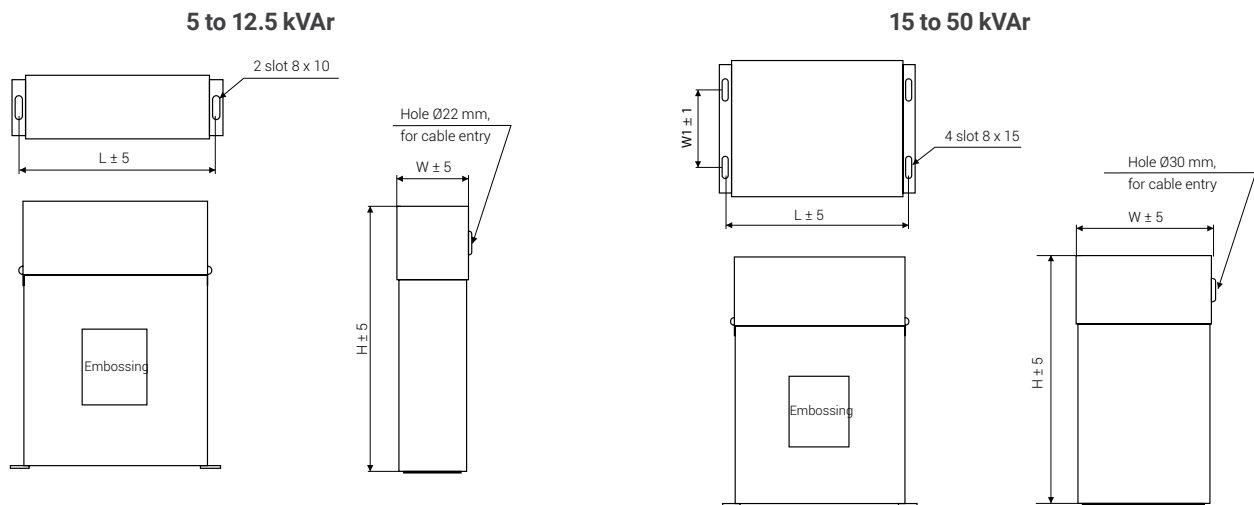

| Sr. No. | Voltage | Power Rating (kVAr) |       | Capacitance (µF) | Rated Current (A) | Dimensions in mm |     |     |     | Cat. No.   |
|---------|---------|---------------------|-------|------------------|-------------------|------------------|-----|-----|-----|------------|
|         |         | 50Hz                | 60Hz  |                  |                   | L                | W   | W1  | H   |            |
| 1       | 440 V   | 1                   | 1     | 16.44            | 1.31              | 125              | 45  | -   | 170 | LTBCH301B2 |
| 2       | 440 V   | 2                   | 2     | 32.88            | 2.62              | 125              | 45  | -   | 170 | LTBCH302B2 |
| 3       | 440 V   | 3                   | 4     | 49.32            | 3.94              | 185              | 60  | -   | 240 | LTBCH303B2 |
| 4       | 440 V   | 4                   | 5     | 65.77            | 5.25              | 185              | 60  | -   | 240 | LTBCH304B2 |
| 5       | 440 V   | 5                   | 6     | 82.21            | 6.56              | 185              | 60  | -   | 240 | LTBCH305B2 |
| 6       | 440 V   | 7.5                 | 9     | 123.31           | 9.84              | 240              | 80  | -   | 300 | LTBCH307B2 |
| 7       | 440 V   | 8.33                | 10    | 136.96           | 10.93             | 240              | 80  | -   | 300 | LTBCH308B2 |
| 8       | 440 V   | 10                  | 12    | 164.42           | 13.12             | 240              | 80  | -   | 300 | LTBCH310B2 |
| 9       | 440 V   | 12.5                | 15    | 205.52           | 16.40             | 240              | 80  | -   | 300 | LTBCH312B2 |
| 10      | 440 V   | 15                  | 18    | 246.62           | 19.68             | 240              | 80  | 75  | 300 | LTBCH315B2 |
| 11      | 440 V   | 20                  | 24    | 328.83           | 26.24             | 240              | 160 | 75  | 300 | LTBCH320B2 |
| 12      | 440 V   | 25                  | 30    | 411.04           | 32.80             | 240              | 160 | 75  | 300 | LTBCH325B2 |
| 13      | 440 V   | 30                  | 36    | 493.25           | 39.37             | 240              | 160 | 75  | 300 | LTBCH330B2 |
| 14      | 440 V   | 50                  | 60    | 822.08           | 65.61             | 240              | 320 | 150 | 350 | LTBCH350B2 |
| 15      | 480 V   | 5.5                 | 6.6   | 90.43            | 9.92              | 185              | 60  | -   | 215 | LTBCH305C2 |
| 16      | 480 V   | 11.1                | 13.32 | 153.35           | 13.36             | 240              | 80  | -   | 300 | LTBCH311C2 |
| 17      | 480 V   | 15                  | 18    | 207.23           | 18.04             | 240              | 80  | 75  | 300 | LTBCH315C2 |
| 18      | 480 V   | 20                  | 24    | 276.31           | 24.06             | 240              | 160 | 75  | 300 | LTBCH320C2 |
| 19      | 480 V   | 25                  | 30    | 345.39           | 30.07             | 240              | 160 | 75  | 300 | LTBCH325C2 |
| 20      | 480 V   | 27.7                | 33.24 | 382.69           | 33.31             | 240              | 160 | 75  | 300 | LTBCH327C2 |
| 21      | 525 V   | 6.6                 | 7.92  | 76.22            | 7.26              | 240              | 80  | -   | 300 | LTBCH306M2 |
| 22      | 525 V   | 13.2                | 15.84 | 127.04           | 12.10             | 240              | 80  | -   | 300 | LTBCH313M2 |
| 23      | 525 V   | 15                  | 18    | 173.23           | 16.50             | 240              | 80  | 75  | 300 | LTBCH315M2 |
| 24      | 525 V   | 20                  | 24    | 230.97           | 21.99             | 240              | 160 | 75  | 300 | LTBCH320M2 |
| 25      | 525 V   | 25                  | 30    | 288.72           | 27.49             | 240              | 160 | 75  | 300 | LTBCH325M2 |
| 26      | 525 V   | 30                  | 36    | 346.46           | 32.99             | 240              | 160 | 75  | 300 | LTBCH330M2 |
| 27      | 525 V   | 33.1                | 40    | 382.26           | 36.40             | 240              | 160 | 75  | 300 | LTBCH333M2 |

# HD Plus Gas Filled Capacitors



E&A's gas filled capacitors are metallised polypropylene capacitors available from 3-33.1 kVAR in cylindrical configuration. These capacitors have an inrush withstand of 300 times  $I_n$  and an overload withstand capacity of 2.0 times  $I_n$ . These capacitors have safety features like over pressure disconnecter and self healing. The gas filled capacitors are subjected to an extended period of drying after which the casing is filled with an inert gas to prevent corrosion of the winding elements and inner electrical contacts. Compact design ensures space saving. Gas Filled capacitors have a long life of 180000 hours.

For Selection and Application details please refer page no.112

## Technical Details

|                                  | Gas Filled Capacitors  |
|----------------------------------|--|
| Series                           | LTCCN  |
| Range                            | 3 - 33.1 kVAR  |
| Standards                        | IS 13340-1993, IS 13341-1992, IEC 60831-1+2  |
| Rated Frequency                  | 50 Hz  |
| Rated Voltage                    | 440 / 480 / 525 V  |
| Over Voltage                     | +10% (8h/24h), +15% (30m/24h), +20% (5m/24hrs), +30% (1m/24hrs)  |
| Over current                     | 2.0 x $I_n$  |
| Peak Inrush Current              | 300 x $I_n$  |
| Operating Losses (Dielectric)    | $\leq 0.2$ W / kVAR  |
| Operating Losses (Total)         | $\leq 0.45$ W / kVAR   |
| Tolerance on Capacitance         | -5 / +10% as per IS  |
| Test Voltage (Terminal-Terminal) | 2.15 times rated voltage for 10 sec  |
| Test Voltage (Terminal-Casing)   | 3 kV (AC) for 1 minute   |
| Degree of Protection             | IP20, indoor mounting  |
| Ambient Temperature              | -40 / D<br>Max temperature = +55°C<br>Max mean temperature (24 h) = +45°C<br>Max mean temperature (1 year) = +35°C |
| Cooling                          | Natural or forced air cooling  |
| Permissible Relative Humidity    | Max 95%  |
| Maximum Operating Altitude       | 4000 m above sea level   |
| Mounting                         | Upright  |
| Safety Features                  | Overpressure disconnecter,<br>Finger-proof terminals, Self-healing   |
| Impregnation                     | Inert gas  |
| Casing                           | Aluminum extruded can  |
| Dielectric Composition           | Metalized polypropylene  |
| Terminals                        | Finger-proof clamptite   |
| Discharge Resistors / Time       | Discharge resistors fitted,<br>Standard discharge time 60 seconds  |
| Switching Operations (maximum)   | 10000 Switchings per year  |
| Life*                            | 1,80,000 hrs   |

\*at standard operating conditions

# Gas Filled Capacitors – Overall Dimensions

## Cylindrical Type

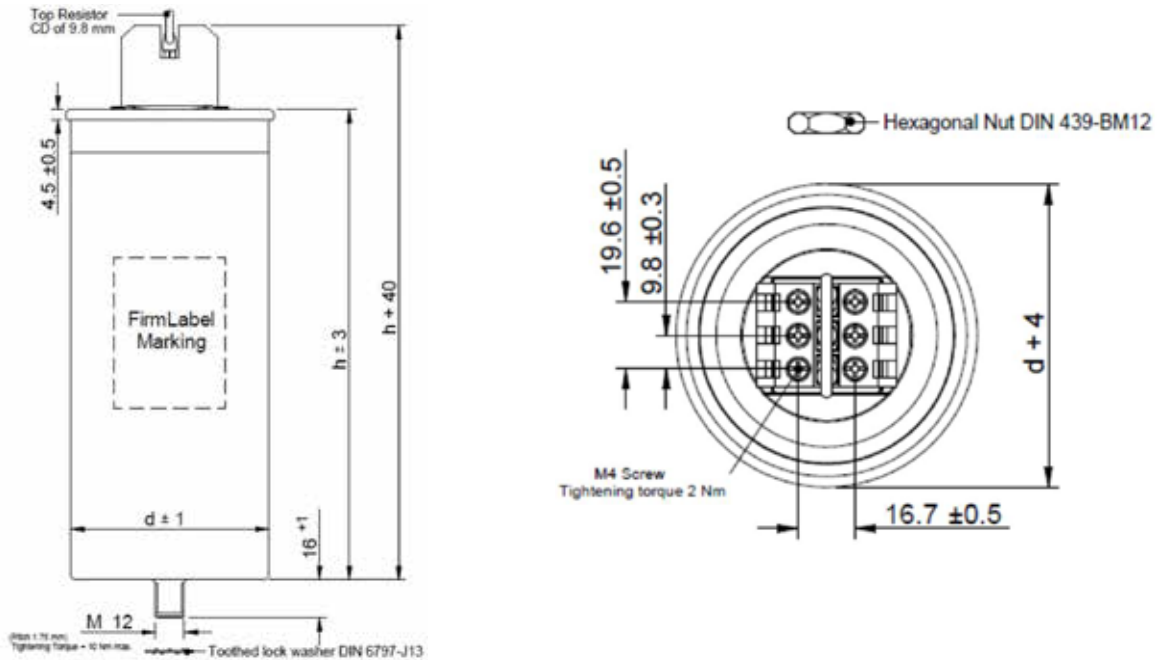

| Sr. No. | Voltage | Power Rating (kVAr) |      | Capacitance ( $\mu$ F) | Rated Current (A) | Dimensions in mm |    | Cat. No.   |
|---------|---------|---------------------|------|------------------------|-------------------|------------------|----|------------|
|         |         | 50Hz                | 60Hz |                        |                   | H                | D  |            |
| 1       | 440 V   | 3                   | 3.6  | 49.32                  | 3.94              | 130              | 64 | LTCCN303B2 |
| 2       | 440 V   | 4                   | 4.8  | 65.77                  | 5.25              | 190              | 64 | LTCCN304B2 |
| 3       | 440 V   | 5                   | 6    | 82.21                  | 6.56              | 190              | 64 | LTCCN305B2 |
| 4       | 440 V   | 7.5                 | 9    | 123.31                 | 9.84              | 172              | 75 | LTCCN307B2 |
| 5       | 440 V   | 8.33                | 10   | 136.96                 | 10.93             | 172              | 75 | LTCCN308B2 |
| 6       | 440 V   | 10                  | 12   | 164.42                 | 13.12             | 208              | 75 | LTCCN310B2 |
| 7       | 440 V   | 12.5                | 15   | 205.52                 | 16.40             | 208              | 75 | LTCCN312B2 |
| 8       | 440 V   | 15                  | 18   | 246.62                 | 19.68             | 208              | 85 | LTCCN315B2 |
| 9       | 440 V   | 20                  | 24   | 328.83                 | 26.24             | 283              | 75 | LTCCN320B2 |
| 10      | 440 V   | 25                  | 30   | 411.04                 | 32.80             | 283              | 85 | LTCCN325B2 |
| 11      | 480 V   | 7.5                 | 9    | 103.62                 | 9.02              | 190              | 64 | LTCCN307C2 |
| 12      | 480 V   | 12.5                | 15   | 172.69                 | 15.04             | 208              | 75 | LTCCN312C2 |
| 13      | 480 V   | 15                  | 18   | 207.23                 | 18.04             | 208              | 85 | LTCCN315C2 |
| 14      | 480 V   | 20                  | 24   | 276.31                 | 24.06             | 283              | 75 | LTCCN320C2 |
| 15      | 480 V   | 25                  | 30   | 345.39                 | 30.07             | 283              | 85 | LTCCN325C2 |
| 16      | 480 V   | 30                  | 36   | 414.47                 | 36.08             | 283              | 90 | LTCCN330C2 |
| 17      | 525 V   | 7.5                 | 9    | 86.61                  | 8.25              | 172              | 75 | LTCCN307M2 |
| 18      | 525 V   | 8.33                | 10   | 96.20                  | 9.16              | 172              | 75 | LTCCN308M2 |
| 19      | 525 V   | 12.5                | 15   | 144.36                 | 13.75             | 208              | 85 | LTCCN312M2 |
| 20      | 525 V   | 15                  | 18   | 173.23                 | 16.50             | 208              | 85 | LTCCN315M2 |
| 21      | 525 V   | 20                  | 24   | 230.97                 | 21.99             | 283              | 85 | LTCCN320M2 |
| 22      | 525 V   | 25                  | 30   | 288.72                 | 27.49             | 283              | 85 | LTCCN325M2 |
| 23      | 525 V   | 30                  | 36   | 346.46                 | 32.99             | 358              | 85 | LTCCN330M2 |
| 24      | 525 V   | 33.1                | 39.7 | 382.26                 | 36.4              | 358              | 85 | LTCCN333M2 |

# Super Heavy Duty Capacitors



E&A's Super Heavy Duty Capacitors are designed and developed to meet reactive power requirements of modern day industries having higher harmonics. These metalized polypropylene capacitors ranges from 1.2-33.3 kVAr with cylindrical type construction. They can withstand peak inrush current of 350 times the rated and an overload withstand capacity of 2.5 times rated current. They have better harmonic withstand capability and long life along with necessary safety features like over pressure disconnecter and self-healing technology.

For Selection and Application details please refer page no.112

## Technical Details

|   | <b>Super Heavy Duty</b>  |
|---|--|
|   | <b>Cylindrical</b>   |
| <b>Series</b>                           | LTCCR  |
| <b>Range</b>                            | 1.2 - 33.3 kVAr  |
| <b>Standards</b>                        | IEC 60831-1+2  |
| <b>Rated Frequency</b>                  | 50 Hz  |
| <b>Rated Voltage</b>                    | 440 / 480 / 525 V  |
| <b>Over Voltage</b>                     | +10% (8h/24h), +15% (30m/24h), +20%(5m/24h), +30% (1m/24h)               |
| <b>Over current</b>                     | 2.5 x In   |
| <b>Peak Inrush Current</b>              | 350 x In   |
| <b>Operating Losses (Dielectric)</b>    | ≤ 0.2 W / kVAr   |
| <b>Operating Losses (Total)</b>         | ≤ 0.45 W / kVAr  |
| <b>Tolerance on Capacitance</b>         | -5% to +5%   |
| <b>Test Voltage (Terminal-Terminal)</b> | 2.15 times rated voltage for 2 s   |
| <b>Test Voltage (Terminal-Casing)</b>   | 5 kV (AC) for 10 s   |
| <b>Degree of Protection</b>             | IP20   |
| <b>Ambient Temperature</b>              | -40°C to 65°C  |
| <b>Cooling</b>                          | Natural or Forced Air Cooling  |
| <b>Permissible Relative Humidity</b>    | Max 95%  |
| <b>Maximum Operating Altitude</b>       | 4000 m above mean sea level  |
| <b>Mounting</b>                         | Universal  |
| <b>Safety Features</b>                  | Overpressure Disconnection System, Finger-proof terminals                |
| <b>Impregnation</b>                     | Non-PCB biodegradable polyurethane self-extinguishing resin              |
| <b>Casing</b>                           | Aluminum case with bottom fixing M12 x 16                                |
| <b>Dielectric Composition</b>           | Metalized Polypropylene  |
| <b>Terminals</b>                        | Optimized capacitor safety terminals with electric shock protection IP20 |
| <b>Discharge Resistors / Time</b>       | Discharge resistors fitted. Standard discharge time 60 seconds.          |
| <b>Switching Operations (maximum)</b>   | 15000 switchings per year  |
| <b>Life*</b>                            | 2,00,000 hrs   |

\*at standard operating conditions

## Super Heavy Duty Capacitors - Overall Dimensions

### Cylindrical Type

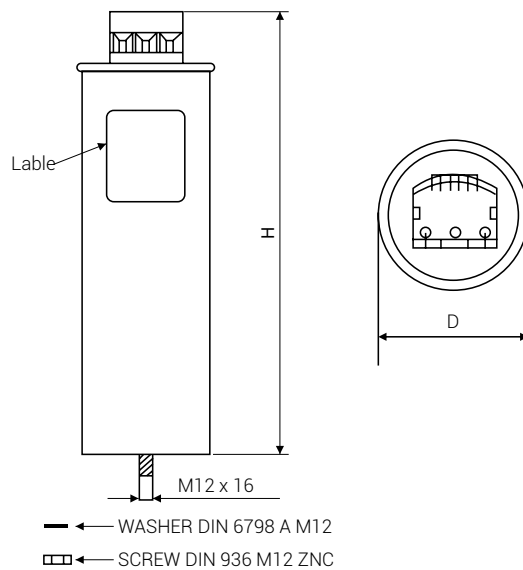

| Sr. No. | Voltage | Power Rating (kVA <sub>r</sub> ) |       | Capacitance (mF) | Rated Current (A) | Dimensions in mm |     | Cat. No.   |
|---------|---------|----------------------------------|-------|------------------|-------------------|------------------|-----|------------|
|         |         | 50Hz                             | 60Hz  |                  |                   | H                | D   |            |
| 1       | 440 V   | 3                                | 4     | 49.32            | 3.94              | 260              | 70  | LTCCR303B2 |
| 2       | 440 V   | 4                                | 4.8   | 65.76            | 5.25              | 260              | 70  | LTCCR304B2 |
| 3       | 440 V   | 5                                | 6     | 82.21            | 6.56              | 260              | 70  | LTCCR305B2 |
| 4       | 440 V   | 7.5                              | 9     | 123.31           | 9.84              | 260              | 85  | LTCCR307B2 |
| 5       | 440 V   | 8.33                             | 10    | 136.96           | 10.93             | 260              | 85  | LTCCR308B2 |
| 6       | 440 V   | 10                               | 12    | 164.42           | 13.12             | 260              | 85  | LTCCR310B2 |
| 7       | 440 V   | 12.5                             | 15    | 205.52           | 16.40             | 260              | 100 | LTCCR312B2 |
| 8       | 440 V   | 15                               | 18    | 246.62           | 19.68             | 260              | 100 | LTCCR315B2 |
| 9       | 440 V   | 20                               | 24    | 328.83           | 26.24             | 265              | 120 | LTCCR320B2 |
| 10      | 440 V   | 25                               | 30    | 411.04           | 32.80             | 265              | 136 | LTCCR325B2 |
| 11      | 480 V   | 1.2                              | 1.4   | 19.73            | 2.16              | 260              | 70  | LTCCR301C2 |
| 12      | 480 V   | 2.2                              | 2.6   | 36.17            | 3.97              | 260              | 70  | LTCCR302C2 |
| 13      | 480 V   | 3.3                              | 4.0   | 54.26            | 5.95              | 260              | 70  | LTCCR303C2 |
| 14      | 480 V   | 4.4                              | 5.3   | 72.34            | 7.94              | 260              | 70  | LTCCR304C2 |
| 15      | 480 V   | 5.5                              | 6.6   | 90.43            | 9.92              | 260              | 85  | LTCCR305C2 |
| 16      | 480 V   | 11.1                             | 13.32 | 153.35           | 13.36             | 260              | 100 | LTCCR311C2 |
| 17      | 480 V   | 15                               | 18    | 207.23           | 18.04             | 265              | 120 | LTCCR315C2 |
| 18      | 480 V   | 20                               | 24    | 276.31           | 24.06             | 265              | 120 | LTCCR320C2 |
| 19      | 480 V   | 25                               | 30    | 345.39           | 30.07             | 265              | 136 | LTCCR325C2 |
| 20      | 480 V   | 27.7                             | 33.24 | 382.69           | 33.31             | 265              | 136 | LTCCR327C2 |
| 21      | 525 V   | 1.3                              | 1.6   | 15.01            | 1.43              | 260              | 70  | LTCCR301M2 |
| 22      | 525 V   | 2.6                              | 3.1   | 30.03            | 2.86              | 260              | 70  | LTCCR302M2 |
| 23      | 525 V   | 3.9                              | 4.7   | 45.04            | 4.29              | 260              | 70  | LTCCR303M2 |
| 24      | 525 V   | 5                                | 6     | 57.74            | 5.49              | 260              | 85  | LTCCR305M2 |
| 25      | 525 V   | 6.6                              | 7.9   | 76.22            | 7.26              | 260              | 85  | LTCCR306M2 |
| 26      | 525 V   | 13.2                             | 15.84 | 127.04           | 12.10             | 260              | 100 | LTCCR313M2 |
| 27      | 525 V   | 15                               | 18    | 173.23           | 16.50             | 265              | 120 | LTCCR315M2 |
| 28      | 525 V   | 20                               | 24    | 230.97           | 21.99             | 265              | 120 | LTCCR320M2 |
| 29      | 525 V   | 25                               | 30    | 288.72           | 27.49             | 265              | 136 | LTCCR325M2 |
| 30      | 525 V   | 30                               | 36    | 346.46           | 32.99             | 265              | 136 | LTCCR330M2 |
| 31      | 525 V   | 33.3                             | 40    | 384.57           | 36.62             | 310              | 136 | LTCCR333M2 |

# LT App Capacitors

APP range of capacitors are Aluminium Polypropylene Capacitors available from 5-50 kVAr in Box type construction. Each capacitor element is protected by an internal fuse which in case of short circuit will blow and isolate that particular capacitor element. These are compact and suitable for applications with heavy load fluctuations and high inrush current. For Selection and Application details, please refer page no. 112



## Technical Details

|   | LT - APP  |
|---|---|
|   | <b>Box</b>  |
| <b>Series</b>                           | LTBCP   |
| <b>Range</b>                            | 5 - 50 kVAr   |
| <b>Standards</b>                        | IS-13585 (Part 1):2012 / IEC-60931-1:1996                       |
| <b>Rated Frequency</b>                  | 50 Hz   |
| <b>Rated Voltage</b>                    | 440 / 480 / 525 V   |
| <b>Over Voltage</b>                     | +10% (8h/24h), +15% (30m/24h), +20% (5m/24h), +30% (1m/24h)     |
| <b>Overcurrent</b>                      | 2.5 x I <sub>n</sub>  |
| <b>Peak Inrush Current</b>              | 300 x I <sub>n</sub>  |
| <b>Operating Losses (Dielectric)</b>    | ≤ 0.2 W/kVAr  |
| <b>Operating Losses (Total)</b>         | ≤ 0.5 W/kVAr  |
| <b>Tolerance on Capacitance</b>         | -5 to +10% as per IS  |
| <b>Test Voltage (Terminal-Terminal)</b> | 2.15 times rated (AC) voltage for 10 s                          |
| <b>Test Voltage (Terminal-Casing)</b>   | 3 kV (AC) for 60 s  |
| <b>Degree of Protection</b>             | IP20  |
| <b>Ambient Temperature</b>              | -5 / D  |
|   | Max temperature = +55°C   |
|   | Max mean temperature (24 h) = +45°C                             |
|   | Max mean temperature (1 year) = +35°C                           |
| <b>Cooling</b>                          | Natural or forced air cooling                                   |
| <b>Permissible Relative humidity</b>    | Max. 95%  |
| <b>Maximum Operating Altitude</b>       | Up to 1000m up to 12.5 kVAr                                     |
|   | Up to 2000m above 12.5 kVAr                                     |
| <b>Mounting</b>                         | Upright   |
| <b>Safety Features</b>                  | Internal fuse element   |
| <b>Impregnation</b>                     | Non PCB, biodegradable oil                                      |
| <b>Casing</b>                           | MS sheet metal  |
| <b>Dielectric Composition</b>           | Biaxially oriented polypropylene (BOPP) film                    |
| <b>Terminals</b>                        | Ceramic bushing,  |
|   | Terminal M-6 threaded for 5 - 15 kVAr                           |
|   | Terminal M-10 threaded for 20 - 50 kVAr                         |
| <b>Discharge Resistors/Time</b>         | Discharge resistors fitted. Standard discharge time 60 seconds. |
| <b>Max Switching Operations</b>         | 10,000 switching per year                                       |
| <b>Life*</b>                            | 2,00,000 hours  |

\*at standard operating conditions

## APP Capacitors - Overall Dimensions

### Box Type

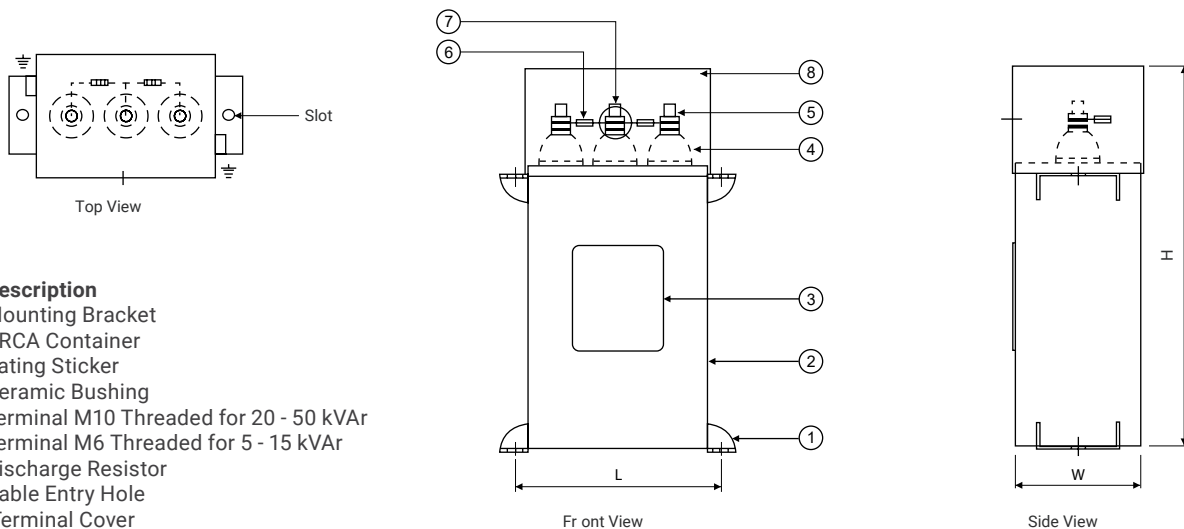

| Item | Description                            |
|------|--|
| 1    | Mounting Bracket                       |
| 2    | CRCA Container                         |
| 3    | Rating Sticker                         |
| 4    | Ceramic Bushing                        |
| 5    | Terminal M10 Threaded for 20 - 50 kVAr |
| 6    | Terminal M6 Threaded for 5 - 15 kVAr   |
| 7    | Discharge Resistor                     |
| 8    | Terminal Cover                         |

| Sr. No. | Voltage | Power Rating (kVAr) |      | Capacitance (μF) | Rated Current (A) | Dimensions in mm |     |     | Mounting Slot in mm | Cat. No.   |
|---------|---------|---------------------|------|------------------|-------------------|------------------|-----|-----|---------------------|------------|
|         |         | 50Hz                | 60Hz |                  |                   | L                | W   | H   |                     |            |
| 1       | 440 V   | 5                   | 6    | 82.21            | 6.56              | 135              | 75  | 330 | Ø 9                 | LTBCP305B2 |
| 2       | 440 V   | 7.5                 | 9    | 123.31           | 9.84              | 135              | 85  | 330 | Ø 9                 | LTBCP307B2 |
| 3       | 440 V   | 10                  | 12   | 164.42           | 13.12             | 135              | 115 | 330 | 10X15               | LTBCP310B2 |
| 4       | 440 V   | 12.5                | 15   | 205.52           | 16.4              | 155              | 115 | 330 | 10X15               | LTBCP312B2 |
| 5       | 440 V   | 15                  | 18   | 246.62           | 19.68             | 175              | 115 | 330 | 10X15               | LTBCP315B2 |
| 6       | 440 V   | 20                  | 24   | 328.83           | 26.24             | 225              | 115 | 355 | 10X15               | LTBCP320B2 |
| 7       | 440 V   | 25                  | 30   | 411.04           | 32.8              | 195              | 115 | 455 | 10X15               | LTBCP325B2 |
| 8       | 440 V   | 50                  | 60   | 822.08           | 65.61             | 335              | 115 | 455 | 10X15               | LTBCP350B2 |
| 9       | 480 V   | 5.5                 | 6.6  | 75.99            | 6.62              | 135              | 75  | 330 | Ø 9                 | LTBCP305C2 |
| 10      | 480 V   | 11.1                | 13.3 | 153.35           | 13.35             | 135              | 115 | 330 | 10X15               | LTBCP311C2 |
| 11      | 480 V   | 13.8                | 16.6 | 190.65           | 16.6              | 155              | 115 | 330 | 10X15               | LTBCP313C2 |
| 12      | 480 V   | 16.6                | 19.9 | 229.34           | 19.97             | 175              | 115 | 330 | 10X15               | LTBCP316C2 |
| 13      | 480 V   | 22.1                | 26.5 | 305.32           | 26.58             | 210              | 115 | 355 | 10X15               | LTBCP322C2 |
| 14      | 480 V   | 27.7                | 33.2 | 382.69           | 33.32             | 185              | 115 | 455 | 10X15               | LTBCP327C2 |
| 15      | 525 V   | 6.6                 | 7.9  | 76.22            | 7.26              | 155              | 115 | 230 | 10X15               | LTBCP306M2 |
| 16      | 525 V   | 13.2                | 15.8 | 152.44           | 14.52             | 135              | 115 | 330 | 10X15               | LTBCP313M2 |
| 17      | 525 V   | 16.6                | 19.9 | 191.71           | 18.26             | 175              | 115 | 330 | 10X15               | LTBCP316M2 |
| 18      | 525 V   | 20                  | 24   | 230.97           | 21.99             | 195              | 115 | 355 | 10X15               | LTBCP320M2 |
| 19      | 525 V   | 26.5                | 31.8 | 306.04           | 29.14             | 245              | 115 | 355 | 10X15               | LTBCP326M2 |
| 20      | 525 V   | 30                  | 36   | 346.46           | 32.99             | 195              | 115 | 455 | 10X15               | LTBCP330M2 |
| 21      | 525 V   | 33.1                | 39.7 | 382.26           | 36.4              | 210              | 115 | 455 | 10X15               | LTBCP333M2 |

# LTXL: Ultra Heavy Duty Cylindrical Capacitors

E&A's LTXL Ultra Heavy duty cylindrical capacitors, like their box counterparts, are sturdy & specially designed to work in very heavy duty applications and high harmonics. They have an inrush current withstand capability of 500 times the rated and an overload withstands capacity of 3 times the rated. In modern industries with high harmonics and high switching rates, it can be an effective solution and delivers long life. It has all necessary safety features of standard capacitors like over pressure disconnect and self-healing technology.

For Selection and Application details, please refer page no. 112



## Technical Details

|   | <b>Ultra Heavy Duty</b>  |
|---|--|
|   | <b>Cylindrical</b>   |
| <b>Series</b>                           | LTCCU  |
| <b>Range</b>                            | 5 - 25 kVAr  |
| <b>Standards</b>                        | IEC 60831-1+2, EN 60831-1+2  |
| <b>Rated frequency</b>                  | 50 Hz  |
| <b>Rated Voltage</b>                    | 440 / 480 / 525 V  |
| <b>Over Voltage</b>                     | +10% (8h/24h), +15% (30m/24h), 20% (5m/24h), +30% (1m/24h)               |
| <b>Overcurrent</b>                      | 3 x In   |
| <b>Peak Inrush Current</b>              | 500 x In   |
| <b>Operating Losses (Dielectric)</b>    | ≤ 0.2 W / kVAr   |
| <b>Operating Losses (Total)</b>         | ≤ 0.45 W / kVAr  |
| <b>Tolerance on capacitance</b>         | -5% to + 5%  |
| <b>Test Voltage (Terminal-Terminal)</b> | 2.15 times rated voltage for 2 s   |
| <b>Test voltage (Terminal-Casing)</b>   | 5 kV (AC) for 1 min.   |
| <b>Degree of protection</b>             | IP20   |
| <b>Ambient Temperature</b>              | -40°C to 65°C  |
| <b>Cooling</b>                          | Natural or Forced Air Cooling  |
| <b>Permissible Relative Humidity</b>    | Max. 95%   |
| <b>Maximum Operating Altitude</b>       | 4000 m above mean sea level  |
| <b>Mounting</b>                         | Universal  |
| <b>Safety Features</b>                  | Overpressure Disconnection System, Finger-proof terminals                |
| <b>Impregnation</b>                     | Non-PCB biodegradable Polyurethane self-extinguishing resin              |
| <b>Casing</b>                           | Aluminum case with bottomfixing M12 x 16                                 |
| <b>Dielectric Composition</b>           | Metalized Polypropylene  |
| <b>Terminals</b>                        | Optimized capacitor safety terminals with electric shock protection IP20 |
| <b>Discharge Resistors/Time</b>         | Discharge resistors fitted. Standard discharge time 60 seconds.          |
| <b>Switching Operations (maximum)</b>   | 18000 switchings per year  |
| <b>Life</b>                             | 3,00,000 hrs   |

\*at standard operating conditions

## LTXL: Ultra Heavy Duty Capacitors - Overall Dimensions

### Cylindrical Type

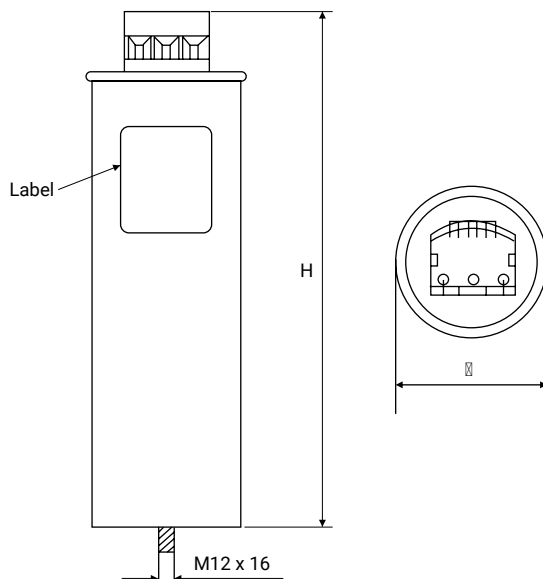

— ← WASHER DIN 6798 A M12

□ ← SCREW DIN 936 M12 ZNC

| Sr. No. | Voltage | Power Rating (kVar) |      | Capacitance (μF) | Rated Current (A) | Dimensions in mm |     | Cat. No.   |
|---------|---------|---------------------|------|------------------|-------------------|------------------|-----|------------|
|         |         | 50Hz                | 60Hz |                  |                   | H                | D   |            |
| 1       | 440 V   | 5                   | 6    | 82.21            | 6.56              | 395              | 70  | LTCCU305B2 |
| 2       | 440 V   | 7.5                 | 9    | 123.31           | 9.84              | 395              | 85  | LTCCU307B2 |
| 3       | 440 V   | 8.33                | 10   | 136.96           | 10.93             | 395              | 85  | LTCCU308B2 |
| 4       | 440 V   | 10                  | 12   | 164.42           | 13.12             | 395              | 100 | LTCCU310B2 |
| 5       | 440 V   | 12.5                | 15   | 205.52           | 16.40             | 395              | 100 | LTCCU312B2 |
| 6       | 440 V   | 15                  | 18   | 246.62           | 19.68             | 400              | 120 | LTCCU315B2 |
| 7       | 440 V   | 20                  | 24   | 328.83           | 26.24             | 400              | 120 | LTCCU320B2 |
| 8       | 440 V   | 25                  | 30   | 411.04           | 32.80             | 400              | 136 | LTCCU325B2 |
| 9       | 480 V   | 7.5                 | 9    | 103.62           | 9.02              | 395              | 85  | LTCCU307C2 |
| 10      | 480 V   | 8.33                | 10   | 115.08           | 10.02             | 395              | 100 | LTCCU308C2 |
| 11      | 480 V   | 10                  | 12   | 138.16           | 12.03             | 395              | 100 | LTCCU310C2 |
| 12      | 480 V   | 12.5                | 15   | 172.69           | 15.04             | 400              | 120 | LTCCU312C2 |
| 13      | 480 V   | 15                  | 18   | 207.23           | 18.04             | 400              | 120 | LTCCU315C2 |
| 14      | 480 V   | 20                  | 24   | 276.31           | 24.06             | 400              | 136 | LTCCU320C2 |
| 15      | 525 V   | 7.5                 | 9    | 86.61            | 8.25              | 395              | 100 | LTCCU307M2 |
| 16      | 525 V   | 10                  | 12   | 115.49           | 11.00             | 395              | 100 | LTCCU310M2 |
| 17      | 525 V   | 12.5                | 15   | 144.36           | 13.75             | 400              | 120 | LTCCU312M2 |
| 18      | 525 V   | 15                  | 18   | 173.23           | 16.50             | 400              | 120 | LTCCU315M2 |
| 19      | 525 V   | 20                  | 24   | 230.97           | 21.99             | 400              | 136 | LTCCU320M2 |

# LTXL: Ultra Heavy Duty Box Capacitors

The LTXL range of capacitors are designed for Ultra heavy duty applications and can withstand heavy load fluctuations, high inrush current and harmonics.

## Applications

- › Applications such as welding, steel rolling, etc., with heavy load fluctuations and high thermal loading
- › Systems with high harmonic distortion levels
- › Systems with high inrush current

## Features

- › Long life expectancy (upto 300000 hrs)
- › Maximum inrush current withstand capability (upto 500 times  $I_R$ )
- › Low power loss (0.35 W / kVAr)
- › Protection with internal fuse

The life of a capacitor largely depends upon its operating temperature. LTXL box type capacitors use advanced APP technology. By employing thicker aluminum foil, thicker hazy polypropylene film and special impregnates, LTXL box type capacitor is able to operate at lower temperatures and hence achieve a longer life. These capacitors are thus able to withstand stringent operating conditions. The higher surface area and special epoxy based coating also ensures better heat dissipation. The capacitor is designed to operate at case temperature up to 70°C.

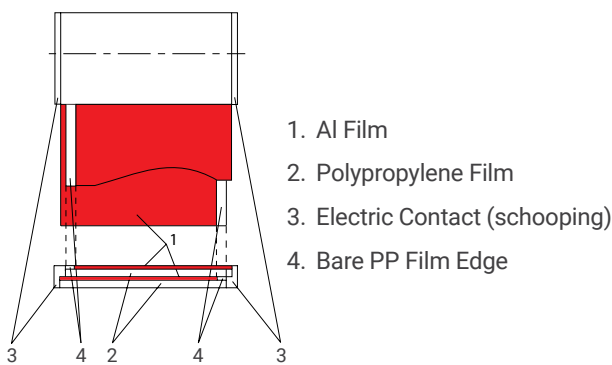

Design of LT Capacitor

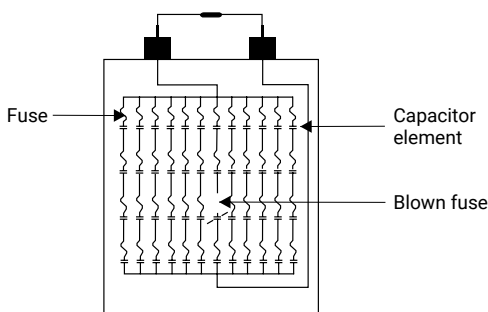

In LTXL box, polypropylene films and two Al films are grouped together as shown in the figure. The wave-cut and heavy edge metalized films are then rolled to form a capacitor element. Many such capacitor elements are pressed and stacked together and are internally connected in parallel. Depending upon the rating of the capacitor, the number of stacks differ. These stacks are placed inside a case and are vacuum impregnated with non-PCB, biodegradable oil (PXE).

Each capacitor element is protected by an internal fuse as shown in the figure. If there is an internal short circuit in any of the capacitor element, the fuse of that corresponding capacitor element blows.

For Selection and Application details please refer page no. 112

## Technical Details

|   |   |
|---|---|
|   | <b>Ultra Heavy Duty</b>   |
|   | <b>Box</b>  |
| <b>Series</b>                           | LTBCU   |
| <b>Range</b>                            | 5 - 50 kVAr   |
| <b>Standards</b>                        | IS 13585 (Part 1)-2012, IEC 60931-1 1996                            |
| <b>Rated frequency</b>                  | 50 Hz   |
| <b>Rated Voltage</b>                    | 440 / 480 / 525 V   |
| <b>Over Voltage</b>                     | +10% (8h/24h), +15% (30m/24h), +20% (5m/24hrs), +30% (1m/24hrs)     |
| <b>Overcurrent</b>                      | 3 x In  |
| <b>Peak Inrush Current</b>              | 500 x In  |
| <b>Operating Losses (Dielectric)</b>    | ≤ 0.2 W / kVAr  |
| <b>Operating Losses (Total)</b>         | ≤ 0.5 W / kVAr  |
| <b>Tolerance on capacitance</b>         | -5 / +10% as per IS   |
| <b>Test Voltage (Terminal-Terminal)</b> | 2.15 times rated voltage for 10 sec                                 |
| <b>Test voltage (Terminal-Casing)</b>   | 3 kV (AC) for 1 minute  |
| <b>Degree of protection</b>             | IP20, Indoor mounting   |
| <b>Ambient Temperature</b>              | -25 / D (Case temperature 70°C)                                     |
| <b>Cooling</b>                          | Natural or forced air cooling                                       |
| <b>Permissible Relative Humidity</b>    | Max 95%   |
| <b>Maximum Operating Altitude</b>       | 4000 m above sea level  |
| <b>Mounting</b>                         | Upright   |
| <b>Safety Features</b>                  | Internal fuse   |
| <b>Impregnation</b>                     | Non-PCB PXE oil   |
| <b>Casing</b>                           | MS sheet metal with special black Epoxy coating                     |
| <b>Dielectric Composition</b>           | Biaxially oriented polypropylene film with aluminium foil electrode |
| <b>Terminals</b>                        | Ceramic bushing   |
| <b>Discharge Resistors/Time</b>         | Discharge resistors fitted, Standard discharge time 60 seconds      |
| <b>Switching Operations (maximum)</b>   | 20000 Switchings per year   |
| <b>Life</b>                             | 3,00,000 hrs  |

\*at standard operating conditions

# LTXL: Ultra Heavy Duty Capacitors - Overall Dimensions

## Box Type

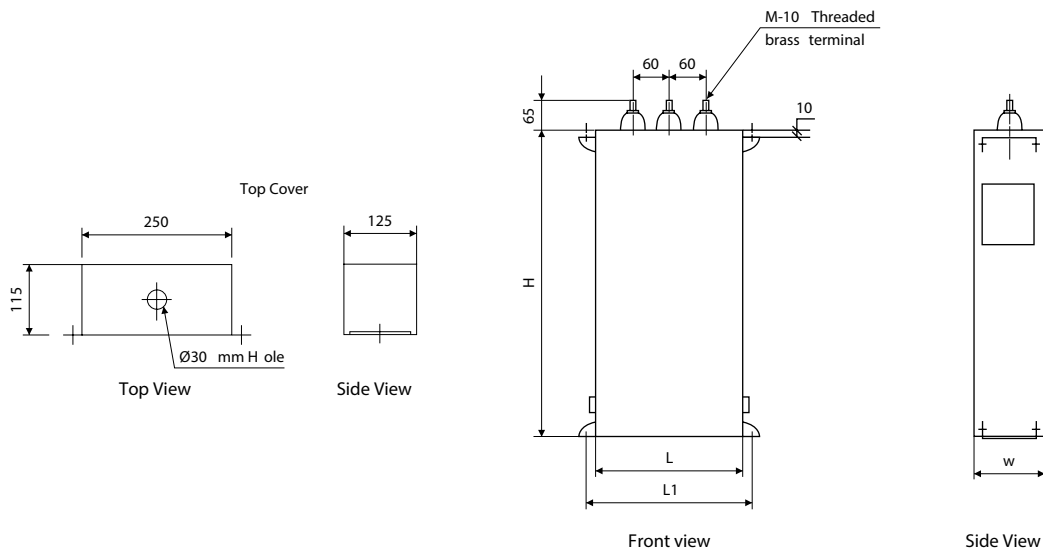

| Sr. No. | Voltage | Power Rating (kVAR) |      | Capacitance (µF) | Rated Current (A) | Dimensions in mm |     |     | Mounting Slot in mm | Cat. No.   |
|---------|---------|---------------------|------|------------------|-------------------|------------------|-----|-----|---------------------|------------|
|         |         | 50Hz                | 60Hz |                  |                   | L1               | W   | H   |                     |            |
| 1       | 440 V   | 5                   | 6    | 82.21            | 6.56              | 265              | 115 | 220 | 10X15               | LTBCU305B2 |
| 2       | 440 V   | 7.5                 | 9    | 123.31           | 9.84              | 265              | 115 | 255 | 10X15               | LTBCU307B2 |
| 3       | 440 V   | 8.33                | 10   | 136.96           | 10.93             | 265              | 115 | 255 | 10X15               | LTBCU308B2 |
| 4       | 440 V   | 10                  | 12   | 164.42           | 13.12             | 265              | 115 | 280 | 10X15               | LTBCU310B2 |
| 5       | 440 V   | 12.5                | 15   | 205.52           | 16.40             | 265              | 115 | 305 | 10X15               | LTBCU312B2 |
| 6       | 440 V   | 15                  | 18   | 246.62           | 19.68             | 265              | 115 | 330 | 10X15               | LTBCU315B2 |
| 7       | 440 V   | 20                  | 24   | 328.83           | 26.24             | 265              | 115 | 380 | 10X15               | LTBCU320B2 |
| 8       | 440 V   | 25                  | 30   | 411.04           | 32.80             | 265              | 115 | 430 | 10X15               | LTBCU325B2 |
| 9       | 440 V   | 30                  | 36   | 493.25           | 39.37             | 265              | 115 | 480 | 10X15               | LTBCU330B2 |
| 10      | 440 V   | 50                  | 60   | 822.08           | 65.61             | 265              | 115 | 680 | 10X15               | LTBCU350B2 |
| 11      | 480 V   | 7.5                 | 9    | 103.62           | 9.02              | 265              | 115 | 255 | 10X15               | LTBCU307C2 |
| 12      | 480 V   | 10                  | 12   | 138.16           | 12.03             | 265              | 115 | 255 | 10X15               | LTBCU310C2 |
| 13      | 480 V   | 12.5                | 15   | 172.69           | 15.04             | 265              | 115 | 280 | 10X15               | LTBCU312C2 |
| 14      | 480 V   | 15                  | 18   | 207.23           | 18.04             | 265              | 115 | 305 | 10X15               | LTBCU315C2 |
| 15      | 480 V   | 20                  | 24   | 276.31           | 24.06             | 265              | 115 | 355 | 10X15               | LTBCU320C2 |
| 16      | 480 V   | 25                  | 30   | 345.39           | 30.07             | 265              | 115 | 405 | 10X15               | LTBCU325C2 |
| 17      | 480 V   | 30                  | 36   | 414.47           | 36.09             | 265              | 115 | 430 | 10X15               | LTBCU330C2 |
| 18      | 525 V   | 7.5                 | 9    | 86.61            | 8.25              | 365              | 115 | 220 | 10X15               | LTBCU307M2 |
| 20      | 525 V   | 12.5                | 15   | 144.36           | 13.75             | 365              | 115 | 255 | 10X15               | LTBCU312M2 |
| 21      | 525 V   | 15                  | 18   | 173.23           | 16.50             | 365              | 115 | 280 | 10X15               | LTBCU315M2 |
| 22      | 525 V   | 20                  | 24   | 230.97           | 21.99             | 365              | 115 | 305 | 10X15               | LTBCU320M2 |
| 23      | 525 V   | 25                  | 30   | 288.72           | 27.49             | 365              | 115 | 355 | 10X15               | LTBCU325M2 |
| 24      | 525 V   | 30                  | 36   | 346.46           | 32.99             | 365              | 115 | 380 | 10X15               | LTBCU330M2 |
| 25      | 525 V   | 33.1                | 40   | 382.26           | 36.40             | 365              | 115 | 430 | 10X15               | LTBCU333M2 |

# Harmonics

Harmonics is defined as a component of periodic wave (or a signal) whose frequency is integral multiple of the fundamental frequency. Non linear loads such as rectifiers, inverters, variable speed drives, furnaces, etc. create harmonics.

These currents consist of a fundamental frequency component rated at 50 Hz, plus a series of overlapping currents, with frequencies that are multiples of the fundamental frequency. The result is deformation of the current (and, as a consequence, voltage) that has a series of associated secondary effects.

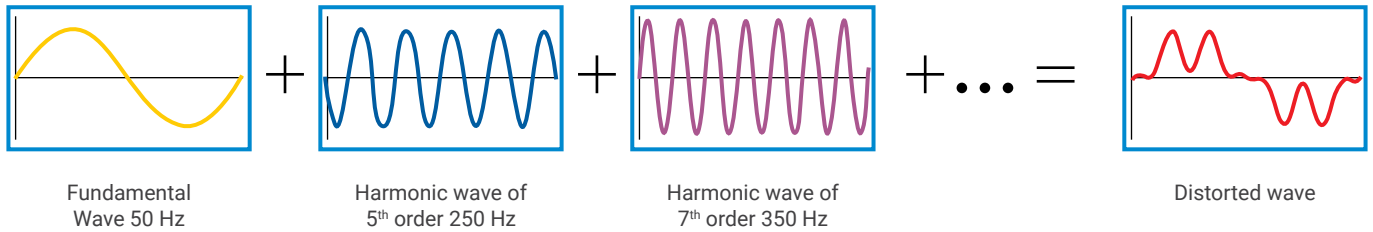

## Types of Harmonic Loads

| Type of Load   | Wave Shape | Harmonic Spectrum THD - I |
|--|------------|---------------------------|
| <ul style="list-style-type: none"> <li>&gt; 6 Pulse and 12 Pulse drive* (VFD &amp; UPS)</li> <li>&gt; Three-phase / Single-phase rectifiers</li> <li>&gt; Arc / Induction furnace</li> </ul> |            |                           |
| <ul style="list-style-type: none"> <li>&gt; Discharge lamps / CFL</li> <li>&gt; Single-phase converters</li> <li>&gt; Computer, IT loads</li> <li>&gt; SMPs</li> <li>&gt; TVs</li> </ul>     |            |                           |

\*Higher the number of pulses, lesser is the harmonic distortion

## III Effects of Harmonics

| Type of Equipment                     | Effect of Harmonics   |
|---------------------------------------|---|
| Rotating Machines                     | Increased power losses, over heating due to skin effect as higher frequency current flows on cable periphery increasing cable resistance, pulsating torque due to negative phase sequence harmonics |
| Transformer, Switchgear, Power Cables | Over-heating, increased power consumption   |
| Protective Relays                     | Mal-operation, nuisance tripping  |
| Power Electronics                     | Mal-operation, failure  |
| Power Capacitors                      | High currents & failure due to overload   |

The above malfunctions are not always felt immediately after the system is installed, but the effects may be felt in the long term and are difficult to distinguish from the natural ageing of equipment. Hence it is important to have some basic knowledge about harmonics and find solutions For the same.

# Harmonic Amplification

Harmonic amplification is an undesired increase in the magnitude of harmonics beyond the level that is being generated in the system. This in turn amplifies the ill effects of the harmonics. This section briefs how the amplification happens in the network and solutions to avoid this amplification.

Capacitive impedance  $X_c = \frac{1}{2\pi fc}$  -----> Eq 1

Hence the capacitor offers lower impedance for high frequency (250 Hz, 350 Hz, 550 Hz and so on). This results in increase in the magnitude of harmonic currents. This can be practically seen by measuring harmonics at a particular location in the electrical network with and without power factor correction capacitors (APFC panels).

Following are the snapshots of harmonic measurement done at the main incomer, with and without capacitors.

Power capacitors are added to the network for improving the power factor. The addition of capacitors results in reduction of system impedance. Capacitive impedance is inversely proportional to frequency (as shown in the figure 1).

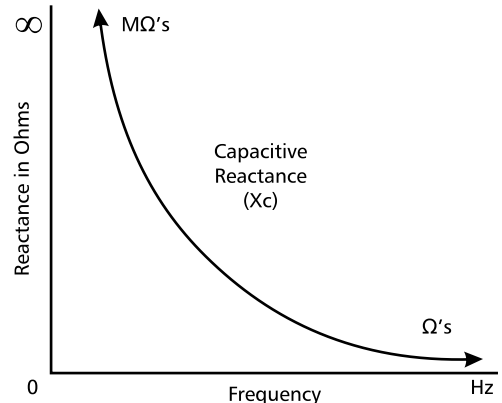
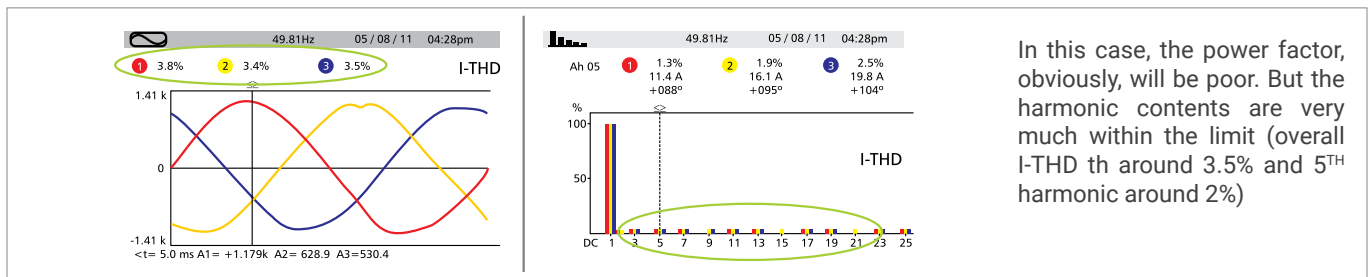

Figure 1

Figure 2: Measurement with APFC Panel OFF



In this case, the power factor, obviously, will be poor. But the harmonic contents are very much within the limit (overall I-THD th around 3.5% and 5<sup>TH</sup> harmonic around 2%)

Figure 3: Measurement with APFC Panel ON

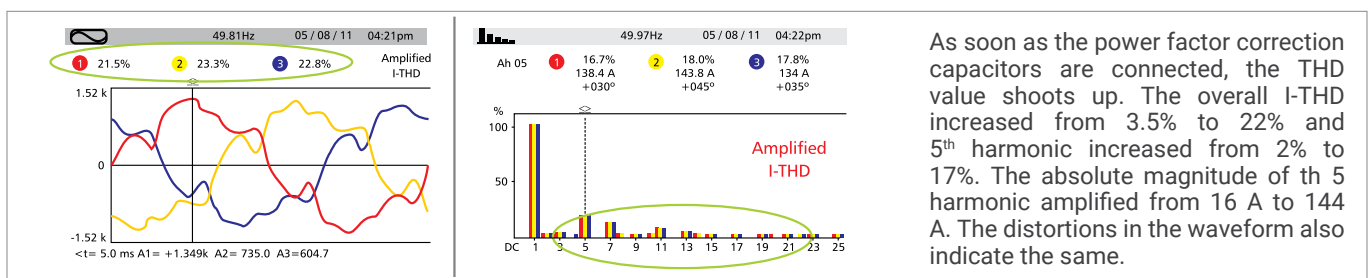

As soon as the power factor correction capacitors are connected, the THD value shoots up. The overall I-THD increased from 3.5% to 22% and 5<sup>th</sup> harmonic increased from 2% to 17%. The absolute magnitude of th 5 harmonic amplified from 16 A to 144 A. The distortions in the waveform also indicate the same.

In the above equation (1), for the same set of harmonic frequencies, on adding more capacitors for PF improvement, the capacitive impedance ( $X_c$ ) will drop further. Again this will result in amplification of the harmonics. If the power factor goes

to leading, the amplification will be worse. The unnecessary amplification of harmonics damages power capacitors and over heats switchgear, cables and busbars.

**The solutions to prevent harmonic amplification are:**

- › By connecting a series inductor, so as to form a detuned filter (series LC), the impedance increases, when the frequency increases (as  $X_L = 2\pi fL$ ). The impedance will be high for high frequency harmonics and no L amplification will happen. Hence, the THD (with reactor + capacitor) will be less than or equal to the earlier THD levels with no capacitors
- › By strictly avoiding leading power factor, the excess addition of capacitors can be prevented and hence the amplification because of this can also be avoided. The optimum power factor of 0.97 to 0.99 should be maintained always

# Harmonic Resonance

Many industries may not generate high harmonics. Sometimes harmonic resonance occurring between power capacitors and transformers causes very high magnification of harmonics. This causes increased rate of failures and over-heating of electrical equipments. This section briefs about the basics of harmonic resonance, a practical case study and solution to avoid resonance.

In a system with inductive ( $X_L$ ) and capacitive ( $X_C$ ) impedances, resonance can happen at one particular frequency (resonant frequency,  $F_R$ ). At this point  $X_L$  is equal to  $X_C$  and the net impedance is very low. Hence, at resonance point, the magnitude of the current (with frequency  $F_R$ ) will be maximum and only inherent resistance in the network would limit the current.

In practical network, the resonance is possible because of one of the following reasons:

- › Parallel resonance within a given electrical system, involving internally generated harmonics (in the load) and resonance between local capacitors and the predominantly inductive supply (transformers)
- › Series resonance involving external harmonics (in the supply system) and resonance between capacitors within electrical system
- › Interactive resonance between different harmonics filters within a given electrical network

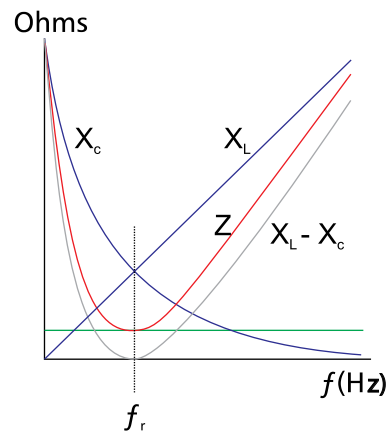

Typically, the inductance ( $L$ , of the transformer) in the system remains almost constant, but the capacitance ( $C$ ) is varied (in steps) as per the requirement to maintain higher power factor.

So, when the capacitance increases the resonant frequency ( $F_R$ ) drops, as  $F_R$  is inversely proportional to square root of capacitance.

$$\text{Resonant frequency } F_R = \frac{1}{2\pi \sqrt{LC}}$$

The lower resonant frequency is dangerous, as it may match with any of the predominant harmonics and cause more damage. Let us see a practical case study of resonance happening between variable PFC capacitors ( $C$ ) and transformer.

Consider an industry with 1000 kVA transformer of  $\%Z = 5.67\%$  and 750 kVAr APFC panel. The resonant frequency can be calculated from the formula:

$$\text{Resonant frequency} = F_s \times \sqrt{\frac{\text{kVA}_{sc}}{\text{kVAr}}}$$

Where  $F_s$  is the System frequency = 50 Hz

$$\text{kVA}_{sc} \text{ is the short circuit power of the transformer } \frac{\text{kVA}}{\%Z/100} = \frac{1000}{0.0567} = 17636 \text{ kVA}$$

kVAr is the power rating of the capacitor connected under the transformer for power factor correction.

## Case 1: When 145 kVAr is Connected to the System,

$$\text{Resonant frequency} = 50 \times \sqrt{\frac{17636}{145}} = 550 \text{ Hz}$$

This frequency exactly matches with 11<sup>th</sup> harmonic (550 Hz) and results in resonance. Following is the harmonics measurement that depicts the 11<sup>th</sup> harmonic resonance, where

it increases from less than 5% to 25%. This huge amplification will damage the capacitor and other equipments.

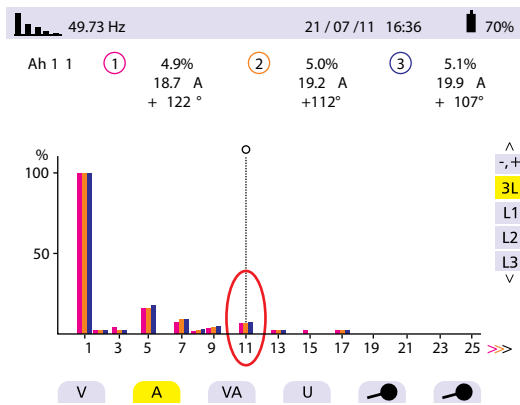

Figure 1: Measurement with APFC Panel OFF

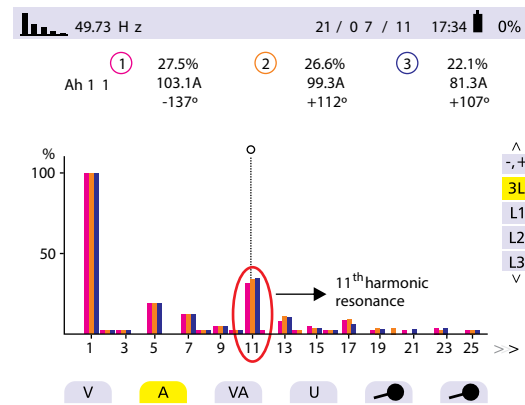

Figure 2: Measurement with APFC Panel ON

### Case 2: When 250 kVAr of Capacitor is Switched on in the Same Industry,

$$\text{Resonant frequency} = 50 \times \sqrt{\frac{17636}{250}} = 420\text{Hz}$$

In this case, no resonance will happen; hence the amplification level will be less than the case1. If harmonics study is carried

at this particular moment, the system would reveal relatively lesser harmonics level (%I-THD)

### Case 3: When 700 kVAr is Connected to the System,

$$\text{Resonant frequency} = 50 \times \sqrt{\frac{17636}{700}} = 250\text{Hz}$$

Once again, this frequency perfectly matches with 5<sup>th</sup> harmonic. Typically 5<sup>th</sup> harmonic is the least order harmonic with higher magnitude (6 pulse drives). Resonance at this harmonic order would result in even worse damage than the case 1.

From the above cases it is evident that any peculiar problem like frequent failure of capacitors, nuisance tripping of MCCBs, frequent blowing of fuses and over-heating of busbars is, may be because of harmonic resonance. Resonance or worst case THD may not be revealed at the moment of harmonic measurement or troubleshooting. Hence at times, finding the root cause of any such failures is very difficult.

Solution for harmonic resonance is to detune, by using a reactor in series with each capacitor. This detuned filter will forcefully create one resonant frequency, so that the combination offers higher impedance for high frequency harmonics. For example, installation of 7% reactor with each capacitor in APFC panel, will create tuning frequency at 189 Hz. Hence, resonance at harmonic frequencies (5<sup>th</sup> harmonics and above) can be avoided. Moreover, all the harmonics having frequency above 189 Hz (i.e., from 5<sup>th</sup> harmonics onwards) will lie in inductive region, where the impedance increases when the frequency increases ( $X_L = 2\pi fL$ ). One important point to note is that all the capacitors in the industry must have similar series inductor; else the overall tuning frequency may not be at 189 Hz.

# Interpretation of Total Harmonic Distortion (THD)

It's a known fact that harmonics cause over loading of power capacitors and consequently reduce the life of power capacitors. Normally lot of emphasis is given only to %THD for assessing the harmonics level while the frequency spectrum (5<sup>th</sup>, 7<sup>th</sup>, 11<sup>th</sup>, 13<sup>th</sup> and so on) of the harmonics are not given due importance.

The over-current (and hence the stress on the capacitors) will not only depend on the %THD value but also on the magnitude of individual harmonics, which can be clearly seen in the frequency spectrum. Following calculations prove the above statement.

## Case 1:

### Assumptions:

- ›  $V_{THD} : 25\%$
- › Harmonic frequencies considered: 5<sup>th</sup> (250 Hz), 7<sup>th</sup> (350 Hz)
- ›  $V_5 = 20\%V$  and  $V_7 = 15\%V_1$
- › All other harmonic frequencies are negligible
- › The capacitors are delta connected hence will not provide a path for the third harmonic to flow

### Important Formulae:

$$X_C = \frac{1}{(2 \pi f C)}$$

where X is the capacitive reactance, f is the frequency, C is the capacitance  $I_c = V_c / X_c$ , where  $I_c$  is the capacitive current,  $V_c$  is the voltage across the capacitor and  $X_c$  is the capacitive reactance

$$V_{THD} = \sqrt{\sum (V_i^2)} / V_1, \text{ where } i=3 \text{ to } 99$$

### Calculations:

Using the superposition theorem, we can calculate the current contribution of individual harmonic voltages.

$$I_5 = V_5 / X_{c5} = 0.2V_1 / [1/(2 \times \pi \times 5 \times f \times C)] = 0.2 \times 5 \times V_1 / X_{c1} = 1 \times V_1 / X_{c1} = I_1$$

Similarly,

$$I_7 = 1.05I_1$$

The total current I will be a vector sum of  $I_1$ ,  $I_5$  and  $I_7$

$$\text{Thus } I = \sqrt{\left( I_1^2 + I_5^2 + I_7^2 \right)} = \sqrt{\left( 1 + 1 + 1.1025 \times I_1^2 \right)}$$

$$\text{Net current, } I = 1.8 I_1 \text{ -----> (1)}$$

## Case 2:

### Assumptions:

- >  $V_{\text{THD}} : 25\%$
- > Harmonic frequencies considered: 5<sup>th</sup> (250 Hz), 7<sup>th</sup> (350 Hz), 11<sup>th</sup> (550 Hz), 13<sup>th</sup> (650 Hz)
- >  $V_5 = 18\%V_1$ ,  $V_7 = 15\%V_1$ ,  $V_{11} = 8\%V_1$  and  $V_{13} = 4\%V_1$

### Calculations:

$$I_5 = V_5 / X_{C5} = 0.18V_1 / [1/(2 \times \pi \times 5 \times X \times f \times C)] = 0.18 \times 5 \times V_1 / X_{C1} = 0.9 \times V_1 / X_{C1} = 0.9I_1$$

Similarly,

$$I_7 = 1.05I_1, I_{11} = 0.88I_1 \text{ and } I_{13} = 0.52I_1$$

The total current  $I$  will be a vector sum of  $I_1$ ,  $I_5$ ,  $I_7$ ,  $I_{11}$  and  $I_{13}$

$$\text{Thus } I = \sqrt{I_1^2 + I_5^2 + I_7^2 + I_{11}^2 + I_{13}^2} = \sqrt{(1^2 + 0.9^2 + 1.05^2 + 0.88^2 + 0.52^2)} \times I_1$$

$$\text{Net current, } I = 2 I_1 \text{ -----} \rightarrow (2)$$

Thus, in the above two cases, even the THD value remains same (25%), the net rms current (ref. Eq 1 and Eq 2) value is different depending upon the spectral values.

Hence THD value and detailed information of the frequency spectrum are necessary to predict the capacitor overcurrent. Harmonics study is the best way to get the frequency spectrum details and hence the exact over current value can be calculated.

# Understanding Current & Voltage Harmonics

Current and voltage harmonics are often used interchangeably. At most places, only harmonics is quoted and whether the

values pertain to current or voltage is not mentioned. The differentiation can be done on the basis of their origin.

## Understanding Total Harmonic Distortion

The current and voltage harmonics in a system are often expressed as Total Harmonic Distortion (THD). The total harmonic distortion, or THD, of a quantity is a measurement of

the harmonic distortion present and is the ratio of all harmonic components to the fundamental component. It is given by the formula as under:

$$THD_Y = \frac{\sqrt{\sum_{h=2}^{\infty} Y_h^2}}{Y_1}$$

Where,  $Y_1$  is the rms value of fundamental  
 $Y_h$  is the rms value of  $h^{th}$  harmonic

Hence, current THD is the ratio of the root-mean-square value of the harmonic currents to the fundamental current.

$$I_{THD} = \frac{\sqrt{\sum_{h=2}^{\infty} I_h^2}}{I_1}$$

## Where do Current & Voltage Harmonics Originate?

Harmonics always originate as current harmonics and voltage harmonics are the results of current harmonics. Current harmonics originate because of the presence of non-linear loads like variable speed drives, inverters, UPS, television sets, PCs, semiconductors circuits, welding sets, arc furnaces in the

system. They act as harmonic current sources. The resulting current waveform can be quite complex depending on the type of load and its interaction with other components of the system.

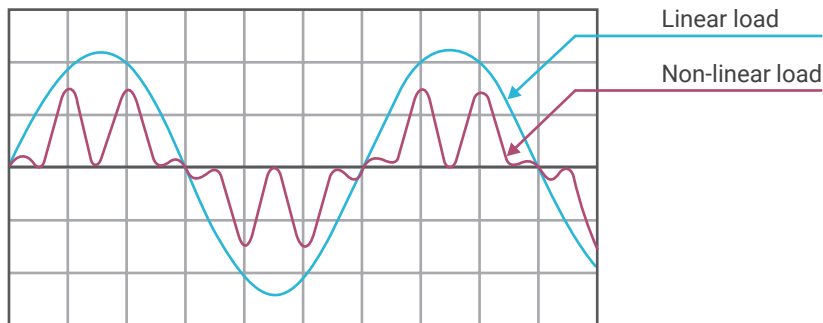
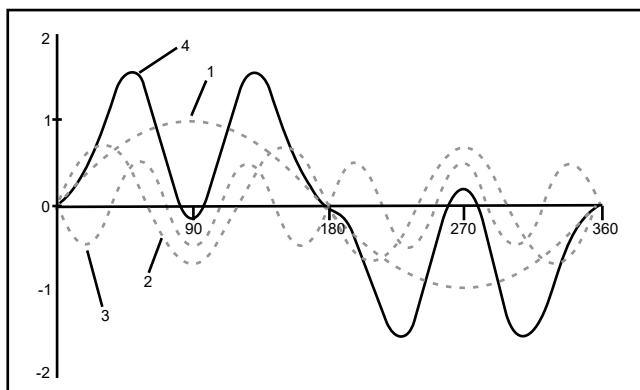

Fig 1: Linear & Non-Linear Loads

The distorted current waveforms can be represented as the sum of current waveform of fundamental frequency and of its multiples (harmonics):



$$f(t) = \sum_{h=1}^{\infty} (C_h \sin(h\omega t + \phi_h))$$

Where,

$c_h$  - Magnitude of  $n^{th}$  order harmonics

$\phi_h$  - Phase angle of  $n^{th}$  order harmonics

Fig 2: Current waveform as sum of fundamental frequency component and its multiples

Voltage harmonics do not originate directly from non-linear loads. The current harmonics (distorted waveform) flow through system impedance (source and line impedances) and cause harmonic voltage drop across the impedances. This will

distort the supply voltage waveform. Thus voltage harmonics are generated. Long cable runs, high impedance transformers, etc. contribute to higher source impedance and hence, higher voltage harmonics.

**A typical power system has the following impedances as indicated in the line diagram:**

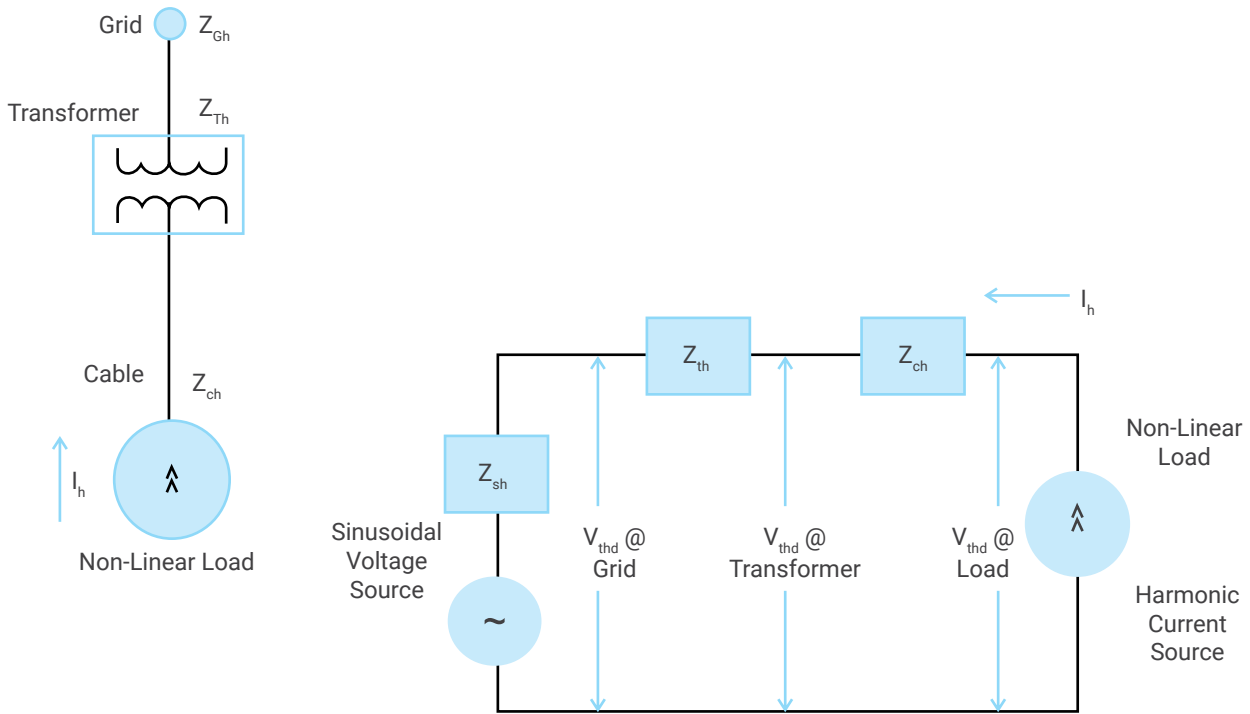

In the above diagram,

$V_h = h^{\text{th}}$  harmonic voltage

$I_h = h^{\text{th}}$  harmonic current

$Z_h =$  Impedance at  $h^{\text{th}}$  harmonic  $h$

$V_{\text{thd}} =$  Voltage total harmonic distortion

At load,  $V_h = I_h \times (Z_{\text{ch}} + Z_{\text{Th}} + Z_{\text{Gh}})$

At transformer,  $V_h = I_h \times (Z_{\text{Th}} + Z_{\text{Gh}})$

At grid,  $V_h = I_h \times (Z_{\text{gh}})$

Usually, grid impedances are very low and hence, the harmonic voltage distortions are also low there. However, they may be unacceptably higher on the load side as they are subjected to full system impedance there. Hence, it becomes important where the harmonics measurements are done.

An industry, say industry A, that has large non-linear loads will generate huge current harmonics in its system. A nearby industry, say industry B, connected to the same grid may not have non-linear loads, yet, it may be subjected to high voltage harmonics. These voltage harmonics are the result of high current harmonics of industry A and impedance of grid &

transformer. Thus, industry B despite small current harmonics, has high voltage harmonics. However, if industry B goes for power factor correction, then, due to the presence of capacitors, current harmonics may also appear in the system, magnifying voltage harmonics further.

### How do Current & Voltage Harmonics Affect the System?

Current harmonics increase the rms current flowing in the circuit and thereby, increase the power losses. Current harmonics affect the entire distribution all the way down to the loads. They may cause increased eddy current and hysteresis losses in motor and transformers resulting in over-heating, overloading in neutral conductors, nuisance tripping of circuit breakers, over-stressing of power factor correction capacitors, interference with communication etc. They can even lead to over-heating and saturation of reactors.

Voltage harmonics affect the entire system irrespective of the type of load. They affect sensitive equipment throughout the facility like those that work on zero-voltage crossing as they introduce voltage distortions.

## Understanding IEEE 519 Guidelines

The purpose of harmonic limits in a system is to limit the harmonic injection from individual customers to the grid so that they do not cause unacceptable voltage distortion in the grid. IEEE 519 specifies the harmonic limits on Total Demand Distortion (TDD) and not Total Harmonic Distortion (THD). TDD represents the amount of harmonics with respect to the maximum load current over a considerable period of time (not the maximum demand current), whereas, THD represents the harmonics content with respect to the actual load current at the time of measurement.

It is important to note here that a small load current may have a high THD value but may not be significant threat to the system as the magnitude of harmonics is quite low. This is quite common during light load conditions.

TDD limits are based on the ratio of system's short circuit current to load current ( $I_{sc} / I_L$ ). This is used to differentiate a system and its impact on voltage distortion of the entire power system. The short circuit capacity is a measure of the impedance of the system. Higher the system impedance, lower will be the short circuit capacity and vice versa.

### The Guidelines IEEE 519-2014 at PCC Level are as under:

| Current distortion limits for General Distribution systems (120V Through 69 kV) |        |         |         |         |         |        |
|---|--------|---------|---------|---------|---------|--------|
| Maximum Harmonic Current Distortion in % $I_L$                                  |        |         |         |         |         |        |
| Individual Harmonic Order (Odd Harmonics)                                       |        |         |         |         |         |        |
| $I_{sc} / I_L$  | 3≤h<11 | 11≤h<17 | 17≤h<23 | 23 h<35 | 35≤h≤50 | TDD    |
| <20   | 4.00%  | 2.00%   | 1.50%   | 0.60%   | 0.30%   | 5.00%  |
| 20-50   | 7.00%  | 3.50%   | 2.50%   | 1.00%   | 0.50%   | 8.00%  |
| 50-100  | 10.00% | 4.50%   | 4.00%   | 1.50%   | 0.70%   | 12.00% |
| 100-1000  | 12.00% | 5.50%   | 5.00%   | 2.00%   | 1.00%   | 15.00% |
| >1000   | 15.00% | 7.00%   | 6.00%   | 2.50%   | 1.40%   | 20.00% |

where

$I_{sc}$  = maximum short-circuit current at PCC [Can be calculated as MVA/(%Z x V)]  
 $I_L$  = maximum demand load current (fundamental frequency component) at PCC

Systems with higher  $I_{sc} / I_L$  have smaller impedances and thus they contribute less in the overall voltage distortion of the power system to which they are connected. Thus, the TDD limits become less stringent for systems with higher  $I_{sc} / I_L$

values. In other words, higher the rating of transformer used for the same amount of load, higher will be the allowable current distortion limits.

| Voltage distortion limits  |                               |           |
|----------------------------|-------------------------------|-----------|
| Bus Voltage at PCC         | Individual Voltage Distortion | $V_{THD}$ |
| $V \leq 1.0$ kV            | 5.00%                         | 8.00%     |
| 1 kV $\leq V \leq 69$ kV   | 3.00%                         | 5.00%     |
| 69 kV $\leq V \leq 161$ kV | 1.50%                         | 2.50%     |
| > 161 kV                   | 1.00%                         | 1.50%     |

The limits on voltage are set at 8% for total harmonic distortion and 5% of fundamental for any single harmonic at PCC level. Harmonics levels above this may lead to erratic functioning of equipment. In critical applications like hospitals and airports,

the limits are more stringent ( less than 3%  $V_{THD}$  ) as erroneous operation may have severe consequences. As discussed already, the harmonic voltage will be higher downstream in the system.

## Solutions for Current & Voltage Harmonics

| Current Harmonics ( $I_{THD}$ ) | Voltage Harmonics ( $V_{THD}$ ) | Recommended Solutions**   |
|---------------------------------|---------------------------------|---|
| High                            | Low ( $\leq 5\%$ )              | Detuned Harmonic Filter with (SHD / LTXL )480 V Capacitors and/or Active Harmonic Filter  |
| High                            | High ( $>5\%$ )                 | Detuned Harmonic Filter (High V-THD Withstand*) with 525V (SHD/LTXL Cyl) Capacitors and/or Active Harmonic Filter   |
| Low                             | High ( $>5\%$ )                 | Grid may be polluted with imported voltage harmonics. It may not be possible to reduce them at the load side. Check with utility to rectify. However, Power factor correction can still be achieved with Detuned Harmonic Filter (High V-THD Withstand*) along with 525V capacitors |

\*\*These are typical solutions. However the actual solution may vary depending up on the actual harmonic content in the system.

\* For High V-THD applications, please contact E&A for customized solutions.

# Triplen Harmonic Mitigation

Triplen harmonics have frequencies in odd multiples of 3, i.e., 3<sup>rd</sup> harmonic (150 Hz), 9<sup>th</sup> harmonic (450 Hz), 15<sup>th</sup> harmonic (750 Hz) and so on. These harmonics have some peculiar

characteristics, which make them very difficult to handle and mitigate. This section explains about the basics, sources, effects and mitigation techniques of triplen harmonics.

## Sources of Triplen Harmonics

Triplen harmonics are usually generated by single phase non-linear loads that share a common neutral. Some of them are,

- › SMPS in computers, televisions, etc.,
- › CFL lamps
- › Electronic dimmers and so on

These types of loads are common in IT parks, office, hospital and other commercial buildings. Following are the typical current harmonic spectra of SMPS and CFL lamps, where third harmonic is predominantly high.

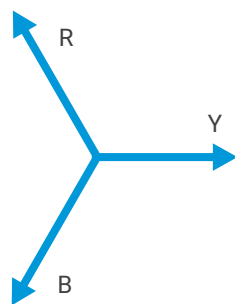

Positive sequence

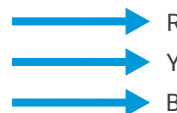

Zero sequence

Neutral current is the vector sum of all the three phase (120° phase displaced) and the sum is zero, if the loads are balanced in all the three phase. But the presence of triplen harmonics

will result in the flow of neutral current, even if the loads are balanced. This phenomenon is explained below:

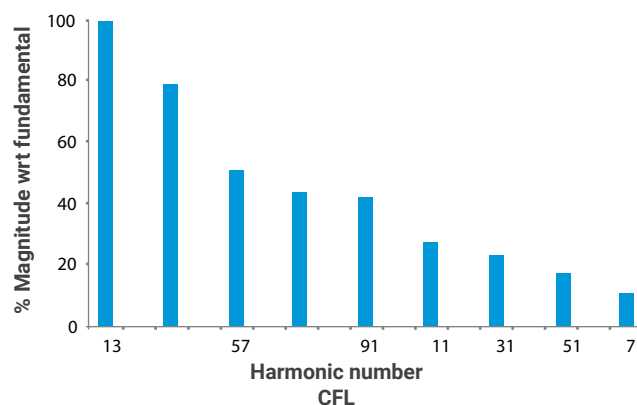
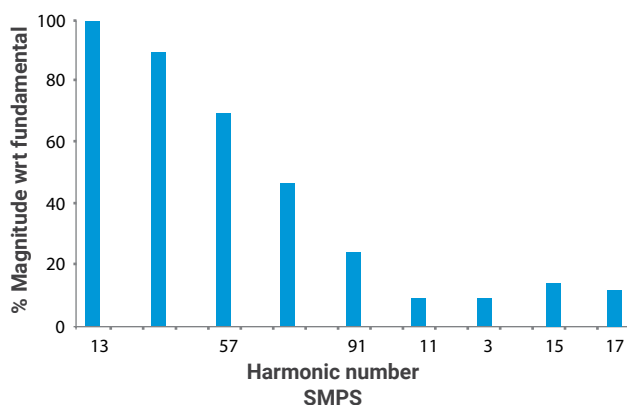

All the triplen harmonics are zero sequence in nature and they are exactly in-phase in all the three phases, where as the

fundamental component (50 Hz), has positive phase sequence, displaced by 120° between the three phases

The accumulated neutral current, because of the additive triplen current, can go up to 200% of the phase current

## Three Phase System

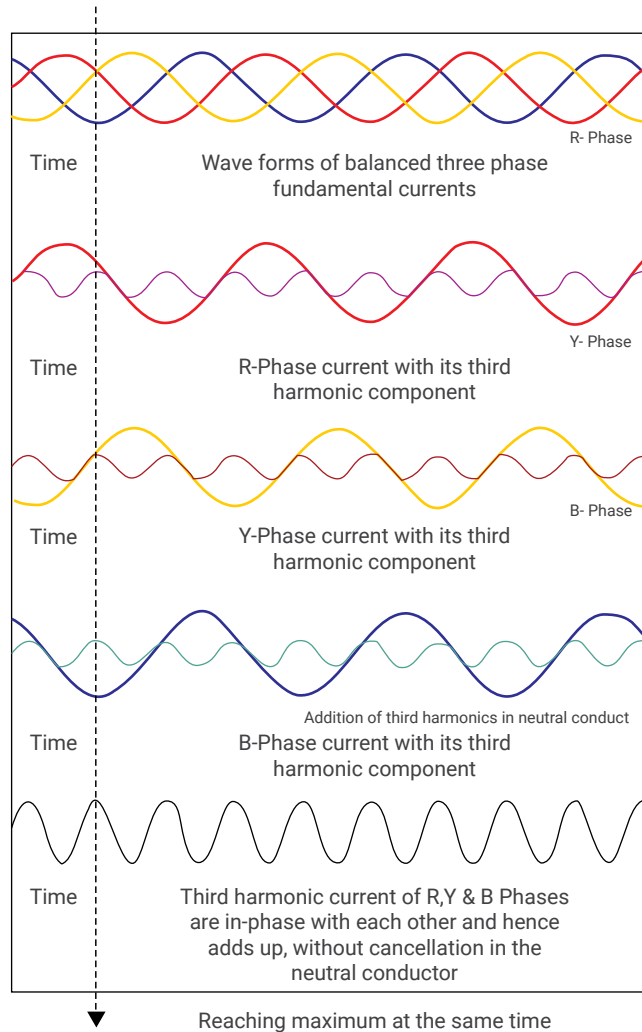

## III Effects of Triplen Harmonics

- › The harmonics accumulate in neutral and cause hot neutral or neutral burning due to neutral over-loading. Thus, we need to use a higher sized cable for neutral
- › Distribution transformer over heating
- › Busbars and cable overheating due to skin effect
- › Eddy current losses (as eddy current is proportional to square of the frequency)
- › Reduced life of electrical equipments like transformers, power capacitors, switchgear, etc.

## Triplen Harmonic Mitigation

Most commonly used passive filter for triplen harmonics is 14% detuned filter. This filter has the tuning frequency of 133 Hz, which is below the 3<sup>rd</sup> harmonic (150 Hz). This filter is very effective in averting the harmonic amplification of 3rd harmonics & above and thereby protecting power capacitors and other equipments. But detuned filter does not eliminate the harmonics completely. In order to achieve that, active harmonic filters with three-phase four-wire configuration should be used.

# Harmonic Mitigation

## Benefits of Harmonics Mitigation

### › Reduction in operating expenses

Harmonic mitigation contributes to reduced power losses in transformers, cables, switchgear. Harmonic mitigation helps in reducing the energy losses

### › Reduction in capital expenditure

Harmonic mitigation reduces the r.m.s. value of the current and it eliminates the need to oversize transformers and hence switchgear, cables and busbars

### › Improved business performance

Harmonics are responsible for increased line currents, resulting in additional power losses and increased temperature in transformers, cables, motors, capacitors. The consequence may be the unwanted tripping of circuit breakers or protection relays. This might cause significant financial losses linked to a process interruption

## Solutions for Harmonic Mitigation

For any electrical system, which is expected to be harmonics rich, it is recommended to study the harmonics level, analyze and then a proper solution should be employed.

The different solutions employed are as follows:

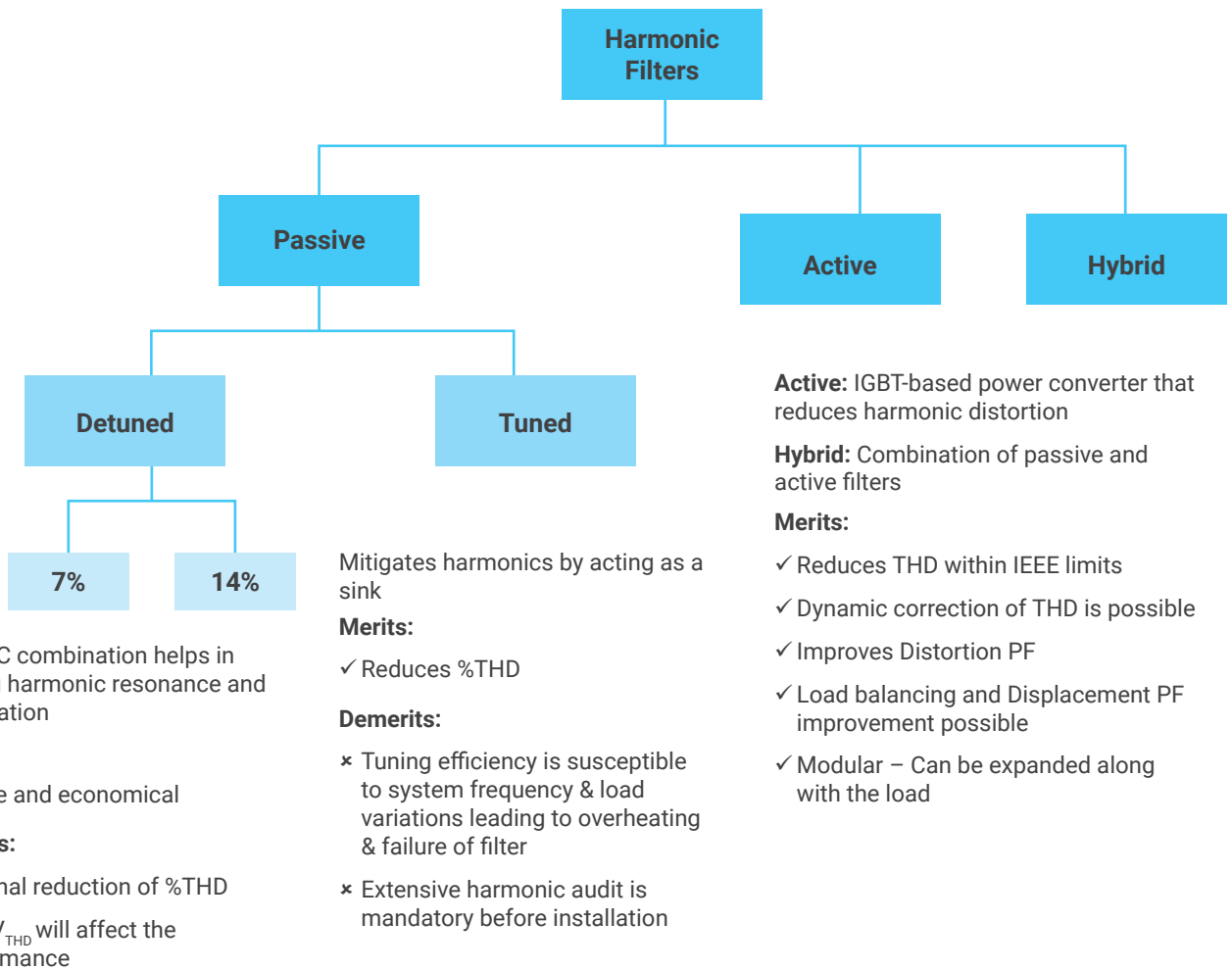

# Detuned Filters

Detuned Filters are a combination of series inductors and power factor correction capacitors that are meant to:

- › Prevent resonance
- › Prevent harmonic amplification
- › Protect power factor correction capacitors from overload

Typically a detuned filter has a series connected capacitor and reactor. The capacitor terminal voltage varies with respect to the tuning factor (%p) of the reactor. Tuning factor (%p) is the ratio of inductive impedance to the capacitive impedance ( $X_L / X_C$ ). Common tuning factors of detuned filters are 7% and 14%.

A tuning factor of 7% implies  $X_L / X_C = 0.07$ .

The tuning frequency using tuning factor can be calculated as:

Every series LC combination behaves capacitive below its tuning frequency [ $f_{res} = 1 / (2\pi \sqrt{LC})$ ] and inductive above. The inductive element of the detuned filter is selected such that the tuning frequency of the filter is significantly lower than the lowest order harmonic frequency present in the system. The filter is thus 'detuned'. The ratio of inductive reactance ( $X_L$ ) and capacitive reactance ( $X_C$ ) is known as the tuning factor.

$$f_t = \frac{f_s}{\sqrt{p/100}} \quad \text{Where,}$$

$f_s$  = Supply Frequency = 50 Hz  
For tuning factor of 7%,  $f_t = 189$  Hz.

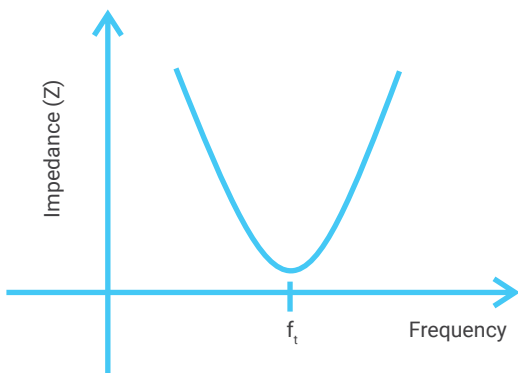

As can be seen from the above graph, for all frequencies above the tuning frequency ( $f_t$ ), the combination will provide increasing impedance. The combination will not provide a low impedance path for harmonics that the capacitor did earlier, thus preventing harmonic amplification. Further as the tuning frequency of the combination is lower than the lowest order harmonic in the system, there is no question of resonance. At 50 Hz the combination behaves capacitive and power factor correction is achieved.

The voltage that appears across the terminals of a capacitor increases the moment you connect an inductor in series with it. This can be illustrated by the below phasor:

$V_s$  : System Voltage;  $V_c$  : Voltage across the capacitor;  $V_L$  : Voltage across the inductor;  $I$  : current.

As can be seen  $V_c > V_s$  by an amount  $V_L$ . Thus if reactors are to be added to an existing APFC panel, the capacitors will have to be replaced with those capable of withstanding higher voltages. More over, the output of the capacitors will have to compensate for the reactive power that will be consumed by the reactor.

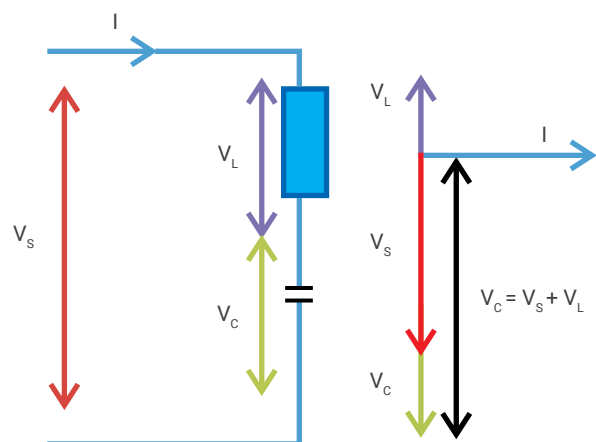

Secondly reactors are a major source of heat. The existing panel may not have sufficient space or cooling arrangement to handle the heat generated by the newly installed reactors. For these reasons, it is not advisable to add detuned reactors to existing APFC panels.

Hence, it is difficult to solve harmonics related problems, once the power factor correcting capacitors are installed. It is thus important to incorporate harmonic mitigation techniques in the system design stage itself.

## Selection of Capacitor - Reactor Combination for Detuned Harmonics Filters

Typically a detuned filter has a series connected capacitor and reactor. The capacitor terminal voltage varies with respect to the tuning factor (%p) of the reactor. Tuning factor (%p) is the ratio of inductive impedance to the capacitive impedance ( $X_L / X_C$ ). Common tuning factors of detuned filters are 7% and 14%.

The voltage that appears across the terminals of a capacitor increases the moment an inductor is connected in series.

The actual amount of voltage increase can be calculated using the following formula:

$$V_c = \frac{V_s}{(1 - \frac{\%p}{100})}$$

› For example, the capacitor terminal voltage with 7% detuned reactor shall be calculated using the above formula:

$$V_c = \frac{440}{(1 - \frac{7}{100})} = 473 \text{ V}$$

Hence the rated voltage of the capacitor should be selected as 480 V when used along with 7% reactor. Sometimes, the voltage variations, as per the electricity board voltage limits, may cause the supply voltage to exceed 480 V. Also, due to

harmonics, both peak and rms voltage may go beyond 480 V. In such cases, a 525 V capacitor should be used along with 7% detuned reactor. Selection for both 480 V and 525 V capacitor with 7% reactor is given in the table.

› When 14% reactor is used along with the capacitor, the capacitor terminal voltage,

$$V_c = \frac{440}{(1 - \frac{14}{100})} = 512 \text{ V}$$

Here the capacitor should be rated for 525 V when used along with 14% reactor.

## Selection of capacitors for detuned harmonic filter application

| Step Size & Reactor rating (440 V) | With 7% detuned reactor                   |                   |                   | With 14% detuned reactor   |                   |
|------------------------------------|---|-------------------|-------------------|--|-------------------|
|                                    | Capacitor Series                          | Capacitor (480 V) | Capacitor (525 V) | Capacitor Series   | Capacitor (525 V) |
| 1                                  | LTCCF, LTCCH, LTCCR                       | 1.2               | 1.3               | LTCCF, LTCCH, LTCCR  | 1.3               |
| 2                                  | LTCCF, LTCCH, LTCCR                       | 2.2               | 2.6               | LTCCF, LTCCH, LTCCR  | 2.6               |
| 3                                  | LTCCF, LTCCH, LTCCR                       | 3.3               | 3.9               | LTCCF, LTCCH, LTCCR  | 3.9               |
| 4                                  | LTCCF, LTCCH                              | 4.4               | 5.3               | LTCCF, LTCCH   | 5.3               |
|                                    | LTCCR                                     |                   | 5                 | LTCCR  | 5                 |
| 5                                  | LTCCF, LTCCH, LTCCR, LT BCH, LTBCP        | 5.5               | 6.6               | LTCCF, LTCCH, LTCCR, LT BCH, LTBCP                               | 6.6               |
|                                    | LTCCN, LTCCU, LTBCU                       | 7.5               | 7.5               | LTCCN, LTCCU, LTBCU  | 7.5               |
| 10                                 | LTCCD, LTCCH, LTCCR, LTBCD, LT BCH, LTBCP | 11.1              | 13.2              | LTCCD, LTCCH, LTCCR, LTBCD, LT BCH, LTBCP                        | 13.2              |
|                                    | LTCCN, LTCCU, LTBCU                       | 12.5              | 12.5              | LTCCN, LTCCU, LTBCU  | 12.5              |
| 12.5                               | LTCCN, LTCCR, LTCCU, LT BCH, LTBCU        | 15                | 15                | LTCCN, LTCCR, LTCCU, LT BCH, LTBCU                               | 15                |
|                                    | LTCCD, LTCCH, LTBCD, LTBCP                | 13.8              | 16.6              | LTCCD, LTCCH, LTBCD, LTBCP                                       | 16.6              |
| 15                                 | LTCCN, LTCCR, LTCCU, LT BCH, LTBCU        | 20                | 20                | "LTCCD, LTCCN, LTCCH, LTCCR, LTCCU, LTBCD, LT BCH, LTBCP, LTBCU" | 20                |
|                                    | LTCCD, LTCCH, LTBCD, LTBCP                | 16.6              |                   |  |                   |
| 20                                 | LTCCN, LTCCR, LT BCH, LTBCU               | 25                | 25                | LTCCN, LTCCR, LT BCH, LTBCU                                      | 25                |
|                                    | LTCCD, LTCCH, LTBCD, LTBCP                | 22.1              | 26.5              | LTCCD, LTCCH, LTBCD, LTBCP                                       | 26.5              |
|                                    | LTCCU                                     | 7.5 + 15          | 2 x 12.5          | LTCCU  | 2x12.5            |
| 25                                 | LTCCD, LTCCH, LTCCR, LTBCD, LT BCH, LTBCP | 27.7              | 33.1              | "LTCCD, LTCCN, LTCCH, LTCCR, LTBCD, LT BCH, LTBCP, LTBCU"        | 30                |
|                                    | LTBCU, LTCCN                              | 30                |                   |  |                   |
|                                    | LTCCU                                     | 12.5 + 15         | 15 + 20           | LTCCU  | (10+20)           |
| 50                                 | LTCCD, LTCCH, LTCCR, LTBCD, LT BCH        | 2 x 27.7          | 2 x 33.1          | "LTCCD, LTCCN, LTCCH, LTCCR, LTBCD, LT BCH, LTBCP, LTBCU"        | 2 x 30            |
|                                    | LTBCU, LTCCN                              | 2 x 30            |                   |  |                   |
|                                    | LTCCU                                     | 2 x (12.5 + 15)   | 2 x (15 + 20)     | LTCCU  | 3 x 20            |
|                                    | LTBCP                                     | 55.3              | 66.2              |  |                   |
| 75                                 | LTCCD, LTCCH, LTCCR, LTBCD, LT BCH        | 3 x 27.7          | 3 x 33.1          | "LTCCD, LTCCN, LTCCH, LTCCR, LTBCD, LT BCH, LTBCP, LTBCU"        | 3 x 30            |
|                                    | LTBCU, LTCCN                              | 3 x 30            |                   |  |                   |
|                                    | LTCCU                                     | 3 x (12.5 + 15)   | 3 x (15 + 20)     | LTCCU  | (4 x 20) + 10     |
|                                    | LTBCP                                     | 27.7 + 55.3       | 33.1 + 66.2       |  |                   |
| 100                                | LTCCD, LTCCH, LTCCR, LTBCD, LT BCH, LTBCP | 4 x 27.7          | 4 x 33.1          | "LTCCD, LTCCN, LTCCH, LTCCR, LTBCD, LT BCH, LTBCP, LTBCU"        | 4 x 30            |
|                                    | LTBCU, LTCCN                              | 4 x 30            |                   |  |                   |
|                                    | LTCCU                                     | 4 x (12.5 + 15)   | 4 x (15 + 20)     | LTCCU  | 6 x 20            |
|                                    | LTBCP                                     | 2 x 55.3          | 2 x 66.2          |  |                   |

\* kVAr selection is based on minimum size required and higher standard rating available

# Importance of Using The Right Detuned Reactor

Electrical networks often contain significant levels of harmonic distortion, which has led the large majority of manufacturers of automatic capacitor banks to unanimously include detuned filter units in their offerings. In this section, we will try to explain the impact of different detuned filters and the consequences of a poor choice, as well as the recommendation for avoiding these possible risks.

## The Importance of Tuning Frequency in Capacitor Banks

There is no such unanimity in the choice of the tuning frequency of the detuned filter offered as standard. In case the network has predominant 3rd order harmonics (150 Hz in 50 Hz networks), the use of detuned filters tuned at 134 Hz is more common (over voltage factor of  $p = 14\%$ ). However, a large majority of installations require capacitor bank fitted with detuned filters appropriate for 5th order harmonics (250 Hz in

50 Hz networks) or higher, which are normally produced by the more usual harmonic current sources, such as, drives, AC/DC rectifiers, induction ovens, etc. In such cases, there

are two options available, that corresponding to an over voltage factor of  $p = 7\%$  (tuning frequency of 189 Hz in 50 Hz networks) and  $p = 5.67\%$  (tuning frequency of 210 Hz in 50 Hz networks). It may seem from the above that the choice of a value of  $p = 7\%$  or  $p = 5.67\%$  might be indifferent and that both should give the same result when they are connected to the electrical network, but this is not strictly true.

## Detuned Filters and Their Effect on Installations

To follow the arguments of this, we will briefly go through the operating principle of detuned filters.

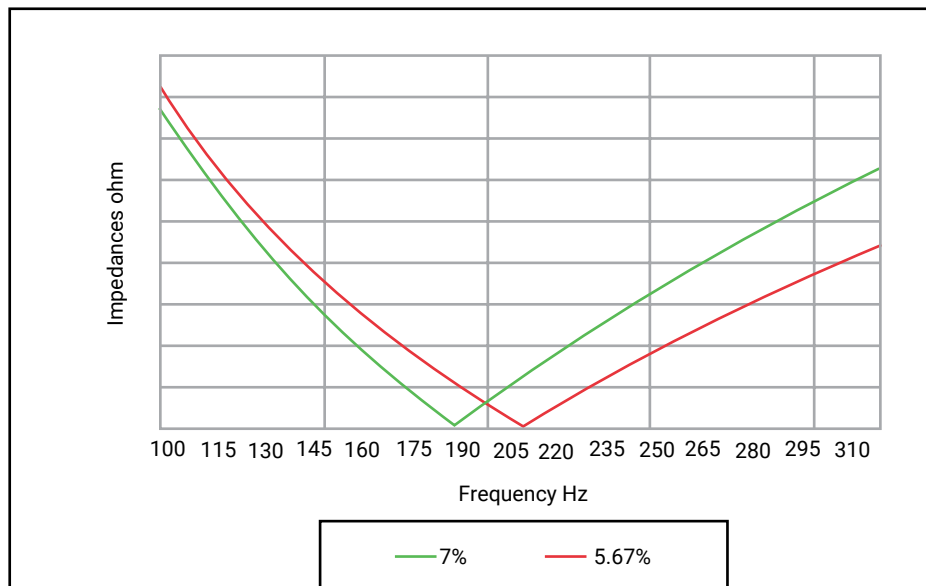

Fig. 1 Impedance-frequency graph of a detuned filter with  $p = 7\%$  (189 Hz) and  $p = 5.67\%$  (210 Hz)

Observing the impedance-frequency graph at rated current of a standard reactor-capacitor unit with  $p = 7\%$  (green line in Fig. 1), we see that it offers least impedance at 189 Hz, whereas that corresponding to  $p = 5.67\%$  (red line in Fig. 1) offers the least impedance at 210 Hz. In both cases, the impedance gradually increases on either side of it. The impedance is capacitive at frequencies under 189 Hz for 7% and 210 Hz for 5.67% respectively, and inductive at higher frequencies. It is

this inductive character with harmonic frequencies of the 5th order or higher that prevents the possibility of a resonance phenomenon being produced at any of those frequencies. However, another key parameter for the correct operation of the detuned filter is the value of impedance at the different harmonic frequencies. Therefore, at said impedance-frequency in Fig. 1 the impedance difference of each tuning can clearly be seen at a harmonic frequency of 250 Hz.

### What is The Main consequence of difference in Impedance Difference Shown By Both Tunings?

For  $p = 5.67\%$ , the value of the impedance is around half of the value for  $p = 7\%$ . Hence its ability to filter of 5th Harmonic and above is only half that of a 7% detuned filter.

The result will be that the absorption of harmonic currents by the capacitor will be higher for  $p = 5.67\%$  than for  $p = 7\%$  as it is providing less impedance to the harmonic frequency.

### Other Effects on The Filtering Tuning

One basic point is the fact that if, to start with, a reactor with  $p = 5.67\%$  is going to have a larger harmonic current consumption, then the reactor and the associated capacitor, must be designed

to withstand the overload to which they are to be subjected on the level of intensity and temperature. However, in the particular case of a similarly-designed reactor with  $p = 7\%$ , the result is a smaller and lighter reactor, and a lower cost. In short, in case of reactor with  $p = 5.67\%$ , there is a risk that the capacitor bank might have to withstand higher levels of harmonic overloading, which would inevitably cause faster wear than in case of a capacitor with filter of  $p = 7\%$ .

The other essential point to be considered, which is the most important, is the influence of the capacitor capacity in tuning the reactor-capacitor series group according to the formula for tuning frequency:

$$f_{\text{res}} = \frac{1}{2\pi\sqrt{LC}}$$

A decrease in the capacitor capacity will result in an increase in the unit's resonance frequency. Capacitors are elements that lose capacity with time either due to their conditions of use (voltage, temperature, connection operation rate, etc.), or due to the natural deterioration of the polypropylene of their dielectrics. A same loss of capacity in a  $p = 5.67\%$  filter and in one of  $p = 7\%$ , means that the first will come much closer to the 5<sup>th</sup> order frequency than the second, and the closer it comes, the greater harmonic current absorption it will present, the greater overloading it will suffer, leading to greater deterioration.

In other words, the safety margin given with this loss of capacity is considerably higher in a filter with  $p = 7\%$

### Conclusions for The Correct Choice of A Reactor

The conclusion in this case is clear, and is the unequivocal recommendation of the use of filters with  $p = 7\%$  instead of  $p = 5.67\%$  in all installations where they have to be applied due to the level of harmonic distortion.

The purpose of this recommendation is none other than to reduce the obvious risk that a loss of capacitor capacity could cause as a result of overcurrent in the capacitor bank much earlier. Thus, 7% detuned reactors allow a longer reaction time through pertinent maintenance actions and the application of corrective measures before the damage is definitive and, therefore, avert worse economic conditions.

# Linearity of Reactor

An industry whose load includes a high proportion of non-linear load (harmonic generating loads), with poor power factor, requires capacitor with de-tuned filter. This performs the function of power factor improvement while preventing harmonic amplification.

Normally, the inductance of the series reactor (of de-tuned filter) connected is chosen such that the tuning frequency of the de-tuned filter is 10% below the lowest harmonic frequency with considerable current/voltage amplitude. Therefore, resonance does not happen in the system and reactor offers high impedance for higher frequency harmonics.

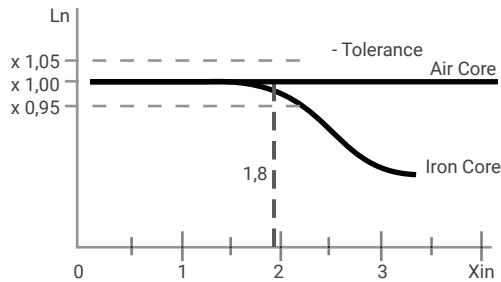

Normally, 7% detuned reactors are designed considering typical industrial loads such as drives that have the following harmonic voltages:  $V_3 = 0.5\% V_N$ ,  $V_5 = 6\% V_N$ ,  $V_7 = 5\% V_N$  and so on. However, if the individual harmonic voltages increase, the following phenomenon happens:

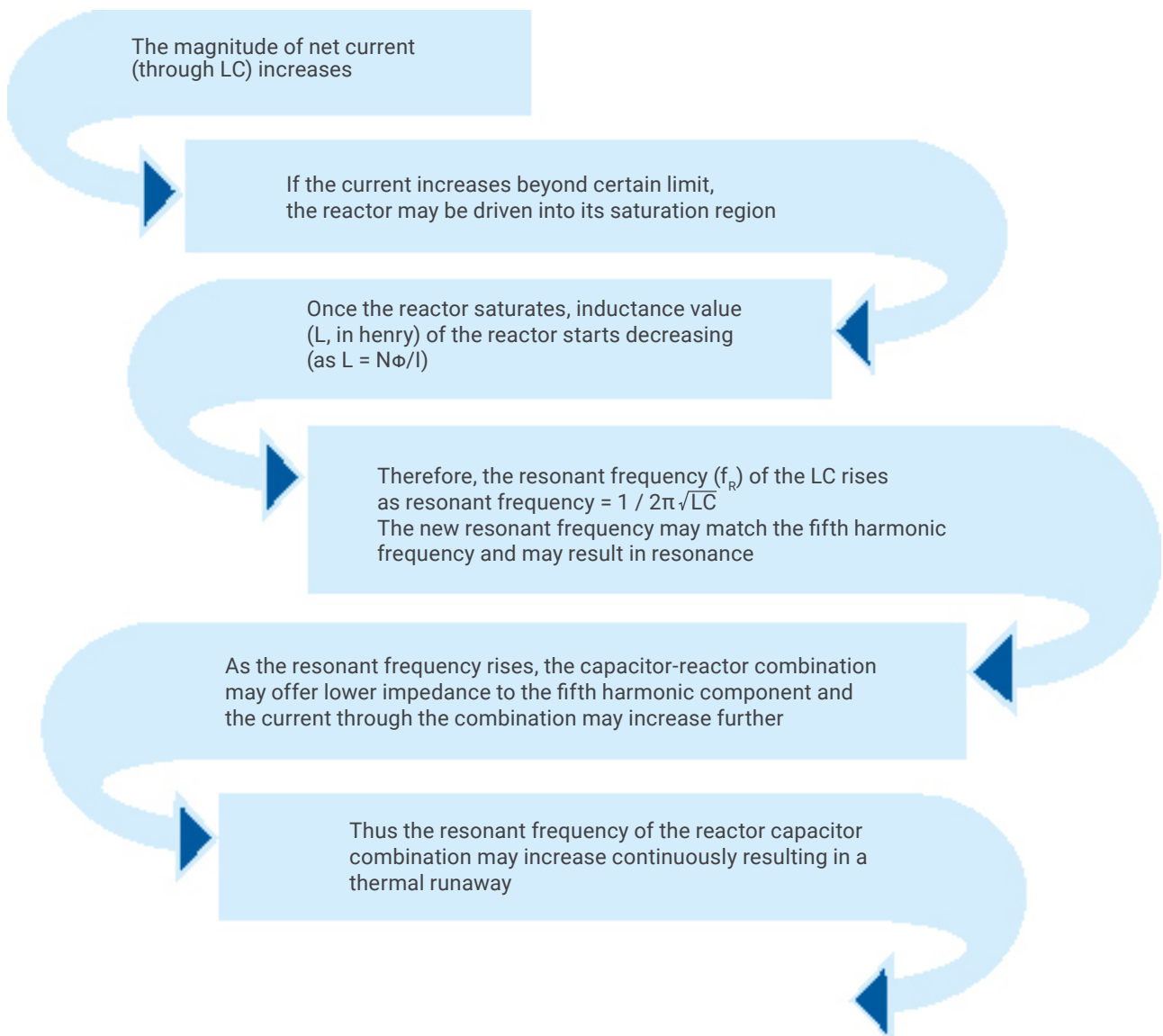

Normally, reactors are designed with predefined linearity. A reactor having a higher linearity does not saturate for higher harmonic currents and prevents the system from a thermal run away as described above.

# Impact of Q-Factor on Performance of Detuned Reactors

The quality factor or Q-Factor is a dimensionless parameter that characterizes a resonator's bandwidth relative to its center frequency. It also describes the damping nature of a resonant circuit. Higher Q indicates a lower rate of energy loss relative to the stored energy of the oscillator; i.e., the oscillations die out more slowly. For example, a pendulum suspended from a high-quality bearing, oscillating in air, has a high Q, while a pendulum immersed in oil has a low one. Oscillators with high quality factors have low damping making them ring longer.

Theoretically, an inductor would have pure inductance only, whereas in reality they have some resistance. This resistance causes energy loss and acts as performance limiting factors for the inductor. Quality Factor helps in defining that performance of the inductor. The Q-Factor is the ratio of Inductive impedance to DC Resistance of detuned reactor.

$$Q\text{-Factor} = \frac{2 \pi fL}{R}$$

**Where,**

f = Frequency; L = Inductance; R = Resistance

Thus, we can calculate the Q-Factor, just by knowing the power factor of the circuit.

$$Q\text{-Factor} = \frac{|\sin \phi|}{|\cos \phi|} = \frac{\sqrt{1-PF^2}}{PF} = \sqrt{\frac{1}{PF^2} - 1}$$

or just the tangent of the phase angle

$$Q \text{ factor} = |\tan \phi|$$

**Effects of Q-factor on filter performance:**

**1. Losses:**

Reactor with high Q-factor has lower power losses. Higher Q-factor implies lower DC resistance value which results in lower  $i^2R$  losses (conductor loss). It can also be explained by below formula:

$$\text{Power Loss} = \frac{\text{Total Power (kVA)}}{Q \text{ factor}}$$

Let us compare the performance of two detuned values: reactors with different Q-factors based on tested

| Detuned reactor - 50 kVA - 7% Tuning factor   |       |      |
|---|-------|------|
|   | 1     | 2    |
| L (mH)  | 0.92  | 0.93 |
| DC Resistance (mΩ)  | 8.97  | 5.01 |
| Q-factor (a)  | 32.2  | 58.3 |
| kVA of reactor (b)<br>(Vr*Ir) + (Vy*Iy) + (Vb*Ib)<br>(V: Voltage drop across the reactor, I: Rated current) | 3845  | 3726 |
| Ohmic power Losses (Watts) (b/a)  | 119.3 | 63.9 |
| Difference (Watts)  | 55.4  |      |

Thus, by choosing the detuned reactor with high Q-factor we can minimise the power loss (conductor loss). The reduction in reactor loss can be as high as 1.5 W/kVA. Consequently,

heat generation (temperature rise) in Power Factor correction panels will also come down.

**2.Impedance offered by reactors:**

A detuned reactor with higher Q-factor has sharper impedance curve. Hence it offers more impedance to higher harmonic frequencies.

Let us study the same based on tested values:

| 50 kVAr Capacitor - 7% Detuned reactor feeder |      |      |
|---|------|------|
|   | Z1   | Z2   |
| Reactor Voltage                               | 440  |      |
| Reactor kVAr                                  | 50   | 50   |
| Q-factor                                      | 32.2 | 58.3 |

As can be seen in the graph, reactor with higher Q-factor offers almost double impedance than the reactor with lower Q-factor for higher order harmonics. All other parameters of both the

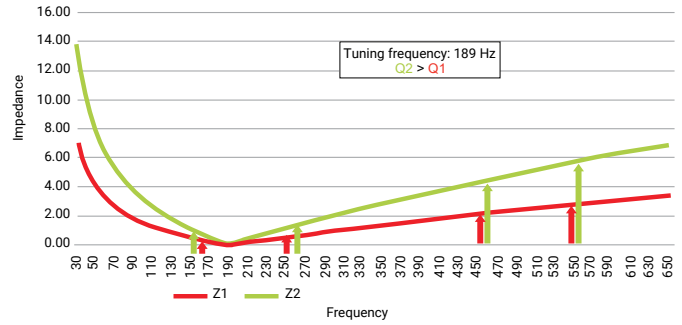

reactors like the inductance, linearity, etc are same, except the Q-factor. The higher impedance results in better reduction of harmonic amplification & resonance

**How to achieve a high Q-factor?**

To achieve good Quality factor, the detuned reactor should have minimum DC resistance as possible.

$$\text{Resistance} = \frac{\rho l}{A}$$

Where, r = Resistivity, l = Length, A = Area of cross-section

1. Resistance is directly proportional to resistivity. Conductor with lower resistivity (copper coil) can be chosen for winding of detuned reactors to get low DC resistance, thereby high Q-factor.

**Conclusion:**

Choosing the detuned reactors with good Q-factor (Quality factor) can help to control harmonic amplification even more effectively. In addition to this, reactors with good linearity limit and proper thermal design of panels will help in bringing the best out of the detuned reactors. While selecting detuned

2. For a relatively higher resistivity materials like Aluminium, the cross-sectional area of the windings to be increased to decrease the effective resistance.

In this study, we have seen the Q-factor of two 50 kVAr 7% reactors one with Q-factor of 32 and other with Q-factor of 58. Practically, Q-factor as high as 58 is easily achievable (refer the above table). But considering other practical factors, any Q-factor value above 35 is preferable

reactors, along with other specification / parameters like Linearity, Power Loss, Insulation class, etc., it is understood from this section that Q-factor should also be given equal importance.

# Reactors - Harmonic Filters

The increasing use of modern power electronic apparatus (drives, uninterruptible power supplies, etc) produces nonlinear current and thus influences and loads the network with harmonics (line pollution).

The capacitance of the power capacitor forms a resonant circuit in conjunction with the feeding transformer. Experience shows that the self-resonant frequency of this circuit is typically between 250 and 500 Hz, i.e. in the region of the 5th and 7th harmonics. Such a resonance can lead to the following undesirable effects:

- › Overloading of capacitors
- › Overloading of transformers and transmission equipment
- › Interference with metering and control systems, computers and electrical gear
- › Resonance elevation, i.e. amplification of harmonics
- › Voltage distortion

These resonance phenomena can be avoided by connecting capacitors in series with filter reactors in the PFC system. These so called "detuned" PFC systems are scaled in a way that the self-resonant frequency is below the lowest line harmonic and the detuned PFC system is purely inductive as seen by harmonics above this frequency. For the base line frequency (50 or 60 Hz usually), the detuned system on the other hand acts purely capacitive, thus correcting the reactive power.



## Features

- › Copper and Aluminium wound reactors
- › Very low operating losses
- › High linearity - 1.8 times the rated current
- › Low noise
- › Auto-thermal cutoff\*\*

| Reactor Tuning Factor | Tuning Frequency | Application (Harmonic Orders)               | Typical Loads   |
|-----------------------|------------------|---|---|
| 7%                    | 189 Hz           | 5 <sup>th</sup> harmonic (250 Hz) and above | 6 pulse drives (AC / DC), 3 phase UPS, frequency converters |
| 14%                   | 133 Hz           | 3 <sup>rd</sup> harmonic (150 Hz) and above | Single phase UPS, CFL lamps, SMPS, dimmers                  |

## Technical Details (Copper and Aluminium)

| Tuning Factor                                  | 7%   | 14%   |
|--|--|---|
| Tuning Frequency                               | 189 Hz   | 134 Hz  |
| Winding  | Copper / Aluminium   |   |
| Standards                                      | IEC 60076-6:2007, IS 5553                                    |   |
| Rated Voltage (V)                              | 440 V  |   |
| Rated Frequency (F)                            | 50 Hz  |   |
| Max Permissible Operating Voltage              | 1.05 Un Continuously, 1.1 Un for 8 hours 1.3 In Continuously |   |
| Max Permissible Operating Current (Irms)       | 1.3 In Continuously  |   |
| Max Permissible Saturation Current (Linearity) | 180% x In  |   |
| Duty Cycle                                     | 100%   |   |
| Ambient Temperature                            | 40 °C  |   |
| Insulation Class                               | Class H  |   |
| Protection                                     | Thermal Switch (NC contact)**                                |   |
| Power Losses (W)                               | Copper Wound   | Aluminium Wound   |
|  | ~ 4 W/kVAr (upto 10 kVAr)<br>~ 3 W/kVAr (above 10 kVAr)      | ~ 5 W/kVAr (upto 10 kVAr)<br>~ 4 W/kVAr (above 10 kVAr) |
| Q-Factor                                       | >35  |   |
| Harmonics Limit                                | V3 = 0.5% VR (duty cycle = 100%)                             |   |
|  | V5 = 6.0% VR (duty cycle = 100%)                             |   |
|  | V7 = 5.0% VR (duty cycle = 100%)                             |   |
|  | V11 = 3.5% VR (duty cycle = 100%)                            |   |
|  | V13 = 3.0% VR (duty cycle = 100%)                            |   |

## 7% & 14% Detuned Reactor (Copper) 440 V - Overall Dimensions

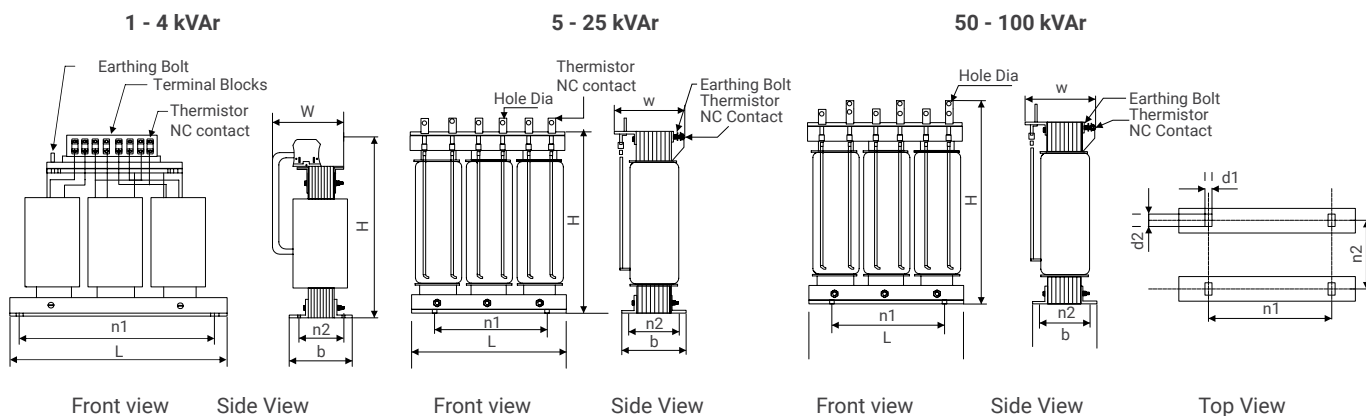

| Tuning factor | kVAr | Cat. No.   | Rated Current (A) | I rms (A) | Inductance (mH) | Terminal Hole | L   | H     | W     | n1  | n2    | b     | d1 | d2 | Weight (kg) |
|---------------|------|------------|-------------------|-----------|-----------------|---------------|-----|-------|-------|-----|-------|-------|----|----|-------------|
|               |      |            |                   |           |                 |               |     |       |       |     |       |       |    |    |             |
| 7%            | 1    | LTFR0701B2 | 1.3               | 1.69      | 46.5            | 6             | 170 | 135±5 | 75±5  | 160 | 55±5  | 71±5  | 6  | 12 | 3           |
| 7%            | 2    | LTFR0702B2 | 2.6               | 3.38      | 23.2            | 6             | 170 | 135±5 | 80±5  | 160 | 60±5  | 76±5  | 6  | 12 | 3.5         |
| 7%            | 3    | LTFR0703B2 | 3.9               | 5.07      | 15.5            | 6             | 170 | 135±5 | 90±5  | 160 | 70±5  | 86±5  | 6  | 12 | 4           |
| 7%            | 4    | LTFR0704B2 | 5.3               | 6.89      | 11.63           | 6             | 170 | 135±5 | 105±5 | 160 | 85±5  | 101±5 | 6  | 12 | 5.5         |
| 7%            | 5    | LTFR0705B2 | 6.6               | 8.58      | 9.28            | 6             | 215 | 175   | 135±5 | 120 | 76±3  | 106±3 | 12 | 20 | 8           |
| 7%            | 10   | LTFR0710B2 | 13.2              | 17.16     | 4.64            | 6             | 215 | 175   | 150±5 | 120 | 91±3  | 121±3 | 12 | 20 | 11.5        |
| 7%            | 12.5 | LTFR0712B2 | 16.5              | 21.45     | 3.72            | 6             | 215 | 175   | 155±5 | 120 | 96±3  | 126±3 | 12 | 20 | 12.5        |
| 7%            | 15   | LTFR0715B2 | 19.8              | 25.74     | 3.09            | 6             | 215 | 175   | 155±5 | 120 | 96±3  | 126±3 | 12 | 20 | 12.5        |
| 7%            | 20   | LTFR0720B2 | 26.4              | 34.32     | 2.32            | 6             | 240 | 220   | 150±5 | 120 | 86±3  | 116±3 | 12 | 20 | 16          |
| 7%            | 25   | LTFR0725B2 | 33                | 42.9      | 1.85            | 6             | 240 | 220   | 155±5 | 120 | 91±3  | 121±3 | 12 | 20 | 17          |
| 7%            | 50   | LTFR0750B2 | 66                | 85.8      | 0.927           | 8             | 300 | 280±5 | 185±5 | 150 | 116±3 | 146±3 | 12 | 20 | 36          |
| 7%            | 75   | LTFR0775B2 | 99                | 128.7     | 0.62            | 8             | 300 | 280±5 | 220±5 | 150 | 151±3 | 181±3 | 12 | 20 | 50          |
| 7%            | 100  | LTFR0700B2 | 132               | 171.6     | 0.464           | 10            | 330 | 315±5 | 220±5 | 240 | 165±3 | 200±3 | 12 | 20 | 56          |
| 14%           | 1    | LTFR1401B2 | 1.3               | 1.69      | 100.3           | 6             | 170 | 135±5 | 80±5  | 160 | 60±5  | 75±3  | 6  | 12 | 3.5         |
| 14%           | 2    | LTFR1402B2 | 2.6               | 3.38      | 50.15           | 6             | 170 | 135±5 | 105±5 | 160 | 85±5  | 101±5 | 6  | 12 | 5.5         |
| 14%           | 3    | LTFR1403B2 | 3.9               | 5.07      | 33.43           | 6             | 215 | 175±5 | 135±5 | 120 | 76±5  | 106±5 | 12 | 20 | 7.5         |
| 14%           | 4    | LTFR1404B2 | 5.3               | 6.89      | 25.08           | 6             | 215 | 175±5 | 135±5 | 120 | 106±5 | 121±5 | 12 | 20 | 10          |
| 14%           | 5    | LTFR1405B2 | 6.6               | 8.58      | 20.06           | 6             | 215 | 175   | 165±5 | 120 | 96±3  | 130±3 | 12 | 20 | 12.3        |
| 14%           | 10   | LTFR1410B2 | 13.2              | 17.16     | 10.03           | 6             | 240 | 225   | 155±5 | 120 | 95±3  | 122±3 | 12 | 20 | 17          |
| 14%           | 12.5 | LTFR1412B2 | 16.5              | 21.45     | 8.024           | 6             | 240 | 225   | 155±5 | 120 | 95±3  | 122±3 | 12 | 20 | 19          |
| 14%           | 15   | LTFR1415B2 | 19.8              | 25.74     | 6.68            | 6             | 240 | 225   | 173±5 | 120 | 111±3 | 141±3 | 12 | 20 | 23          |
| 14%           | 20   | LTFR1420B2 | 26.4              | 34.32     | 5.012           | 6             | 240 | 225   | 178±5 | 120 | 116±3 | 146±3 | 12 | 20 | 27          |
| 14%           | 25   | LTFR1425B2 | 33                | 42.9      | 4.012           | 6             | 300 | 255   | 190±5 | 150 | 112±3 | 145±3 | 12 | 20 | 34          |
| 14%           | 50   | LTFR1450B2 | 66                | 85.28     | 2.006           | 8             | 330 | 305±5 | 220±5 | 240 | 160±3 | 190±3 | 12 | 20 | 54.5        |
| 14%           | 75   | LTFR1475B2 | 99                | 128.7     | 1.34            | 8             | 340 | 320±5 | 220±5 | 240 | 175±3 | 225±3 | 12 | 20 | 69          |
| 14%           | 100  | LTFR1400B2 | 132               | 171.6     | 1.003           | 10            | 400 | 375±5 | 220±5 | 200 | 170±3 | 205±3 | 12 | 20 | 95          |

## 7% & 14% Detuned Reactor (Aluminium) 440 V - Overall Dimensions

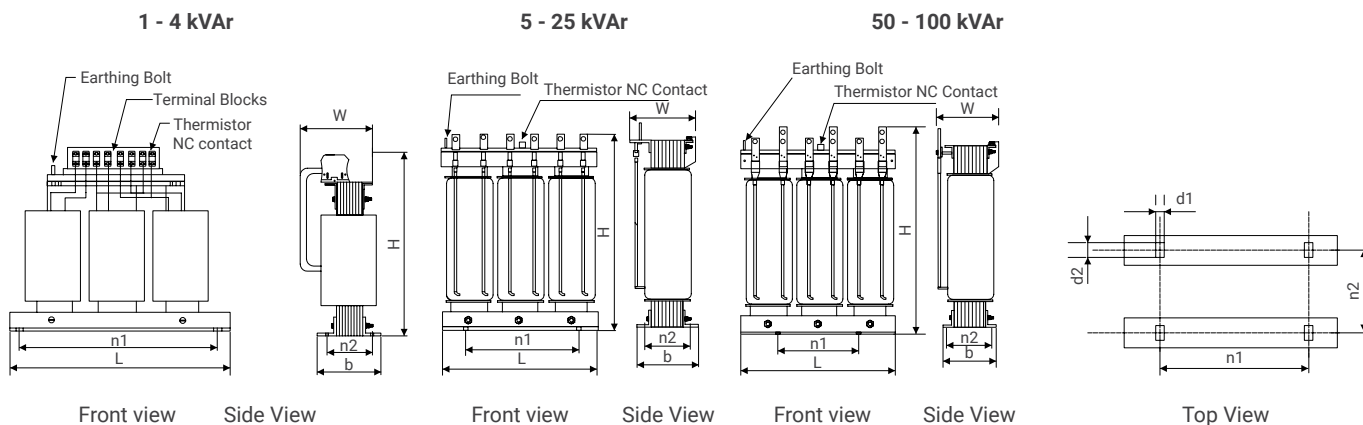

| Tuning factor | kVAr | Cat. No.   | Rated Current (A) | I rms (A) | Inductance (mH) | Terminal Hole | L   | H     | W     | n1  | n2    | b     | d1 | d2 | Weight (kg) |
|---------------|------|------------|-------------------|-----------|-----------------|---------------|-----|-------|-------|-----|-------|-------|----|----|-------------|
|               |      |            |                   |           |                 |               |     |       |       |     |       |       |    |    |             |
| 7%            | 1    | LTAL0701B2 | 1.3               | 1.69      | 46.5            | 6             | 215 | 160±5 | 65±5  | 200 | 48±3  | 71±5  | 8  | 15 | 3.8         |
| 7%            | 2    | LTAL0702B2 | 2.6               | 3.38      | 23.2            | 6             | 215 | 160±5 | 93±5  | 200 | 61±5  | 84±5  | 8  | 15 | 5.2         |
| 7%            | 3    | LTAL0703B2 | 3.9               | 5.07      | 15.5            | 6             | 215 | 160±5 | 113±5 | 200 | 74±5  | 97±5  | 8  | 15 | 6.68        |
| 7%            | 4    | LTAL0704B2 | 5.3               | 6.89      | 11.63           | 6             | 215 | 175±5 | 70±5  | 200 | 60±5  | 83±3  | 8  | 15 | 6.5         |
| 7%            | 5    | LTAL0705B2 | 6.6               | 8.58      | 9.28            | 6             | 215 | 175   | 130±5 | 203 | 80±3  | 95±3  | 8  | 12 | 7           |
| 7%            | 10   | LTAL0710B2 | 13.2              | 17.16     | 4.64            | 6             | 215 | 175   | 155±5 | 203 | 92±3  | 108±3 | 8  | 12 | 9           |
| 7%            | 12.5 | LTAL0712B2 | 16.5              | 21.45     | 3.72            | 6             | 215 | 175   | 160±5 | 203 | 105±3 | 123±3 | 8  | 12 | 11          |
| 7%            | 15   | LTAL0715B2 | 19.8              | 27.45     | 3.09            | 6             | 215 | 175   | 196±5 | 203 | 130±3 | 150±3 | 8  | 12 | 14          |
| 7%            | 20   | LTAL0720B2 | 26.4              | 34.32     | 2.32            | 6             | 250 | 225   | 155±5 | 150 | 110±3 | 135±3 | 12 | 20 | 18          |
| 7%            | 25   | LTAL0725B2 | 33                | 42.9      | 1.85            | 6             | 270 | 260   | 170±5 | 150 | 108±3 | 140±1 | 12 | 20 | 21          |
| 7%            | 50   | LTAL0750B2 | 66                | 85.8      | 0.92            | 8             | 270 | 375   | 210±5 | 150 | 108±3 | 140±3 | 12 | 20 | 32          |
| 7%            | 75   | LTAL0775B2 | 99                | 128.7     | 0.62            | 8             | 270 | 375   | 210±5 | 150 | 108±3 | 140±3 | 12 | 20 | 49          |
| 7%            | 100  | LTAL0700B2 | 132               | 171.6     | 0.46            | 10            | 370 | 325   | 200±5 | 180 | 135±3 | 175±3 | 12 | 20 | 48          |
| 14%           | 1    | LTAL1401B2 | 1.3               | 1.69      | 11.3            | 6             | 215 | 160±5 | 70±5  | 200 | 60±5  | 83±5  | 8  | 15 | 5.5         |
| 14%           | 2    | LTAL1402B2 | 2.6               | 3.38      | 50.12           | 6             | 215 | 175±5 | 70±5  | 200 | 60±5  | 83±5  | 8  | 15 | 5.5         |
| 14%           | 3    | LTAL1403B2 | 3.9               | 5.07      | 25.08           | 6             | 215 | 175±5 | 80±5  | 200 | 60±5  | 95±5  | 8  | 15 | 6.5         |
| 14%           | 4    | LTAL1404B2 | 5.3               | 6.89      | 0.62            | 6             | 215 | 175±5 | 90±5  | 200 | 92±5  | 108±5 | 8  | 15 | 8.5         |
| 14%           | 5    | LTAL1405B2 | 6.6               | 8.58      | 20.06           | 6             | 215 | 180   | 155±5 | 200 | 90±3  | 108±5 | 12 | 20 | 10          |
| 14%           | 10   | LTAL1410B2 | 13.2              | 17.16     | 10.03           | 6             | 250 | 225   | 185±5 | 150 | 110±3 | 135±3 | 12 | 20 | 18          |
| 14%           | 12.5 | LTAL1412B2 | 16.5              | 21.45     | 8.024           | 6             | 250 | 255   | 170±5 | 150 | 110±3 | 123±3 | 12 | 20 | 18          |
| 14%           | 15   | LTAL1415B2 | 19.8              | 25.74     | 6.68            | 6             | 270 | 260   | 170±5 | 150 | 130±3 | 160±3 | 12 | 20 | 26          |
| 14%           | 20   | LTAL1420B2 | 26.4              | 34.32     | 5.015           | 6             | 270 | 260   | 195±5 | 150 | 150±3 | 180±3 | 12 | 20 | 31          |
| 14%           | 25   | LTAL1425B2 | 33                | 42.9      | 4.012           | 6             | 270 | 360   | 175±5 | 150 | 110±3 | 135±3 | 12 | 20 | 34          |
| 14%           | 50   | LTAL1450B2 | 66                | 85.8      | 2.006           | 8             | 370 | 305   | 230±5 | 180 | 135±3 | 175±3 | 12 | 20 | 47          |
| 14%           | 75   | LTAL1475B2 | 99                | 128.7     | 1.24            | 8             | 370 | 305   | 270±5 | 180 | 180±3 | 215±3 | 12 | 20 | 68          |
| 14%           | 100  | LTAL1400B2 | 132               | 171.6     | 1.003           | 10            | 350 | 410   | 260±5 | 205 | 180±3 | 205±3 | 12 | 20 | 82          |

# Active Harmonic Filter (AHF)

## Basics of AHF

The increasing use of energy saving power electronics based loads (adjustable speed drives, switch mode power supplies, etc.) to improve system efficiency and controllability, is increasing the concern for harmonic distortion levels in end use facilities and on the overall power system. Active filter is the apt device for reducing harmonic levels in industrial and commercial facilities to meet IEEE 519 guidelines. The concept of active filter, what many try to explain is, it senses harmonics and generates 180° phase shifted harmonics that cancels out the unwanted harmonics. This section, specifically describes the basic operation of active filters in a little more detailed way.

### Principle of Operation

An active harmonic filter is based on the following principle:

$$I_{FILTER} = I_{MAIN} - I_{LOAD}$$

It detects the difference between the ideal current sine wave ( $I_{MAIN}$ ) and the actual current which has been deformed by harmonics ( $I_{LOAD}$ ). It, then, injects this difference ( $I_{FILTER}$ ), which is the negative of the harmonic currents present in the load current, into the system on a real-time basis. This cancels out the high frequency harmonics and results in almost pure sine wave.

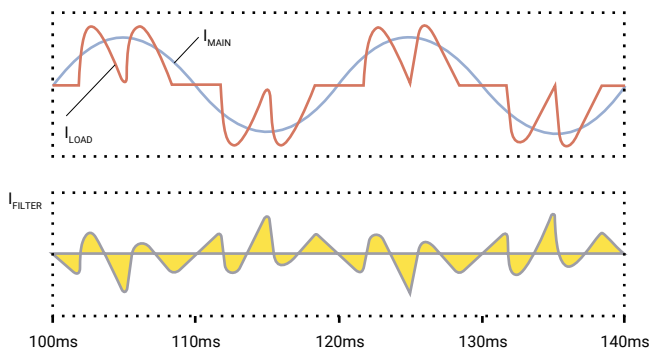

Wave Shapes of The Currents -  $I_{MAIN}$ ,  $I_{LOAD}$  &  $I_{FILTER}$

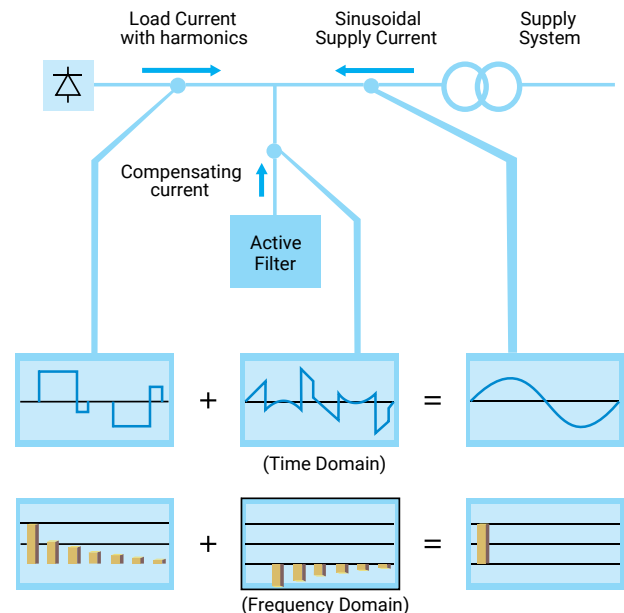

Line Diagram of Active Harmonic Filter

The use of active harmonic filters helps in reducing harmonics as can be seen under:

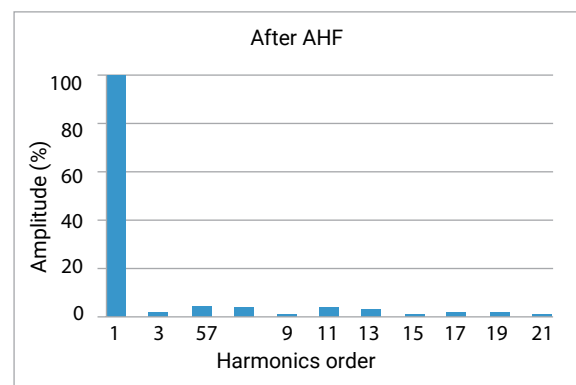
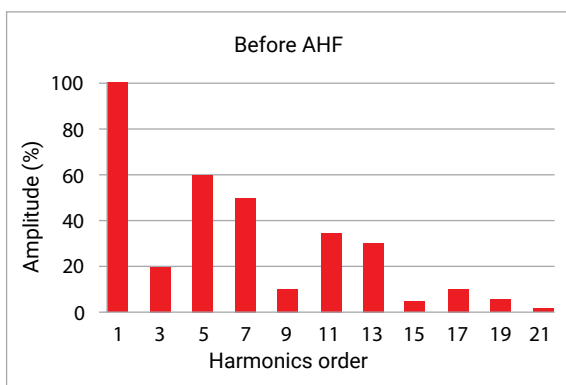

Frequency Spectrum of Current Before and After Active Harmonic Filtering

Some of the areas where active harmonic filters can be used are:

- › In areas with critical loads like automobile industry, precision equipment manufacturing etc., the harmonic load may vary frequently. This may have immediate adverse impacts like poor quality of manufactured products and equipment failures leading to huge monetary losses. Active filters prove to be suitable as they provide real-time reduction of THD
- › Certain segments like textile industry, having huge VFD loads suffer from high harmonics. Due to this, the use of detuned

filters may not be adequate, resulting in frequent capacitor failures and overheating or saturation of reactors. Only active harmonic filters provide necessary solutions in such cases

- › Active harmonic filters have an added advantage of providing unsymmetrical reactive power compensation and also, provide load balancing
- › Even usage of 14% reactor may not be sufficient to reduce neutral overloading due to triple-N harmonics. However, 3 phase, 4 wire active filter helps in achieving the same more effectively

## AHF - Concepts & Connections

The active filter uses power electronic switching to generate harmonic currents that cancel the harmonic currents from a nonlinear load. The active filter configuration is based on a Pulse-Width Modulated (PWM\*\*) voltage source inverter that interfaces to the system through an Interface Filter as shown in Figure 1. In this configuration, the filter is connected

in parallel with the load being compensated. Therefore, the active filter with this configuration is often referred to as shunt active filter. Figure 1 illustrates the concept of the harmonic current cancellation so that the current being supplied from the source is sinusoidal.

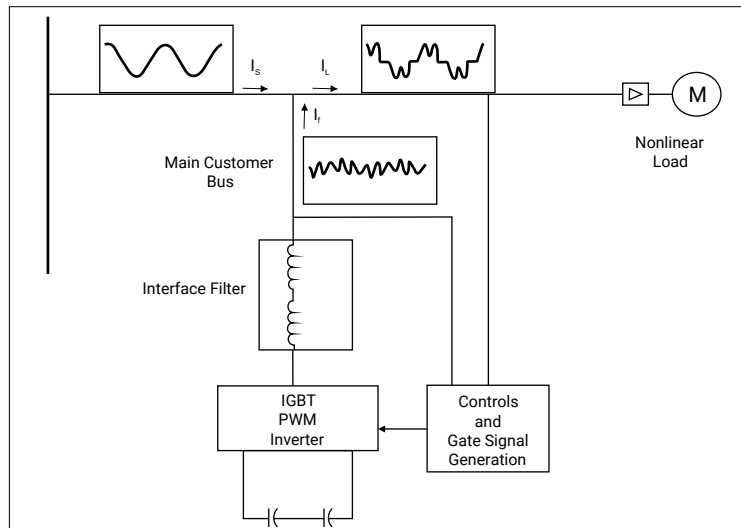

Figure 1

\*\*Pulse Width Modulation is a technique used to generate the effect of any wave-form by varying the width of the DC pulse. The width (duty cycle) is varied by employing faster switching devices (IGBT with switching frequency in kHz). Higher the switching frequency, better will be the intended wave-form but higher will be the power losses.

The voltage source inverter used in the active filter makes the harmonic control possible. This inverter uses DC capacitors as the supply and can switch at a high frequency to generate

a signal which will cancel the harmonics from the nonlinear load. One leg of the inverter is shown in Figure 2 to illustrate the configuration.

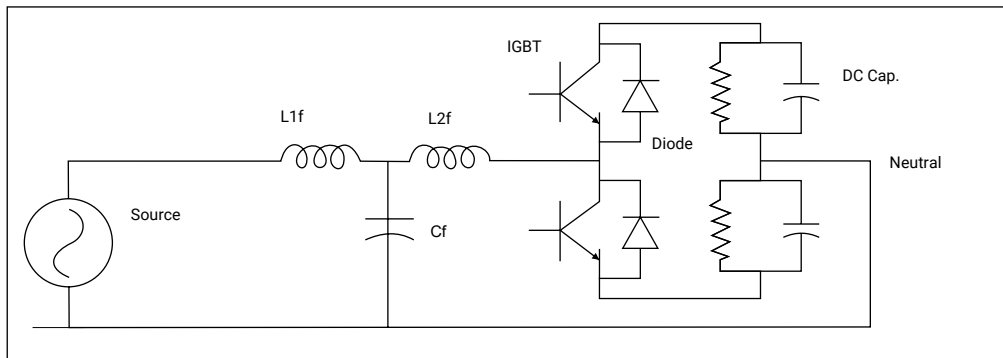

Figure 2

The current waveform for cancelling harmonics is achieved with the voltage source inverter and an interfacing filter. The filter consists of a relatively large isolation inductance to convert the voltage signal created by the inverter to a current signal for cancelling harmonics. The rest of the filter provides smoothing and isolation for high frequency components. The desired current waveform is obtained by accurately controlling the switching of the IGBTs in the inverter. Control of the current

wave shape is limited by the switching frequency of the inverter and by the available driving voltage across the interfacing inductance.

The active filter does not need to provide any real power to cancel harmonic currents from the load. The harmonic currents to be cancelled show up as reactive power.

## Connections & CT installations of AHF

For the stable operation of active harmonic filter and for the expected reduction of harmonics, the physical connection & location of power cables & CTs plays a critical role. Let us understand the connections through the below two cases.

**Case 1:** In case any industry faces severe problems due to harmonics like over-heating of equipments, failure of power capacitors, frequent card failures, etc., it is advisable to arrest the harmonics right at the source. The connection shall be as below:

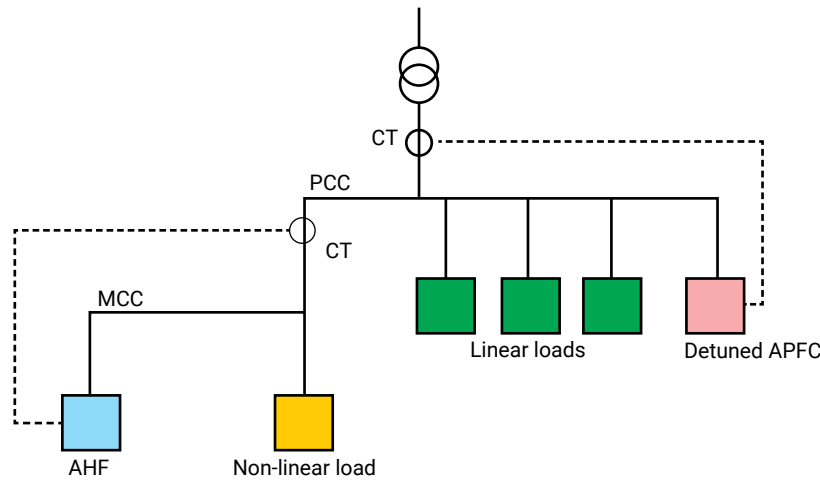

Make sure that the APFC panels are detuned and are connected in the upstream of the AHF. Detuning of APFC panel helps in optimising the AHF rating, as detuning avoids the harmonic amplification. Connecting AHF below the APFC avoids the AHF being overloaded due to unwanted harmonic resonances. Also make sure that the CT of AHF shall be connected below the CT of APFC panel.

**Case 2:** If almost all the main feeders from PCC generates high harmonics, ideally each feeder shall be compensated with individual AHF. But this will increase the installation cost and requires more space. Also managing all the AHF will be difficult. In such cases, a common AHF can be connected for harmonics compensation, as shown below:

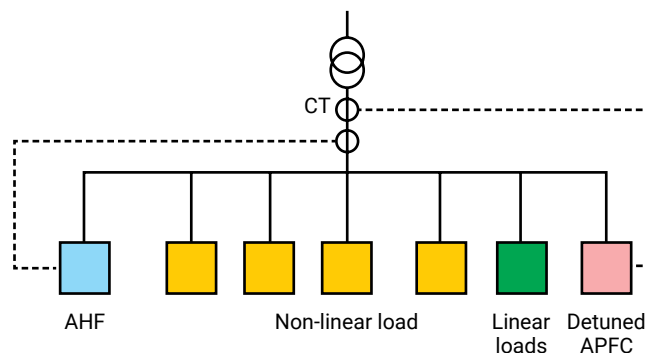

Also make sure that the APFC panels are detuned and the AHF CT shall be below the CT of detuned APFC panels. This method is also simple enough, especially for industries where harmonics need to be reduced at the HT side, in order to meet utility regulations (like Tamil Nadu Electricity Board).

In some rare cases, there may be multiple sources, like two or more synchronised transformers. In such cases, individual CTs shall be connected to each sources and the common signal can be given to AHF through a summation CT.

## Open loop connection Vs closed loop connection

The open loop or closed loop connection is indicated by the location, where harmonics are measured by the

In **open loop connection**, CT is installed close to load, as indicated in the given figure. AHF senses the harmonics that are being generated by the load and generates the compensating harmonics based on that data. Advantage of this connection is faster harmonic compensation. But a drawback in this connection is, the AHF won't get any feedback from the system and does not know whether the harmonics compensation is happening properly or not. Also, as no feedback exists, the resulting line current may typically contain error components that are not detected by the control system. This connection works better when AHF is connected close to the load and not at PCC / main incomer.

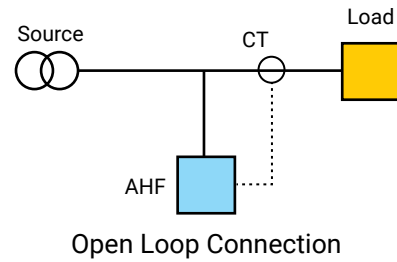

In **closed loop connection** the CT is installed close to source. Here, CT actually measures the compensated current. In other words, AHF senses the difference between load current and the AHF compensating current. If CT senses any harmonics, corrective action is taken by the AHF, till CT senses close to sine wave. In this method of connection, the AHF gets system feedback and any measurement or other inaccuracies can be automatically cancelled out. Even though, closed loop connection is not as fast as open loop, closed loop ensures better harmonics compensation. This type of connection works better, anywhere in the system, than the open loop.

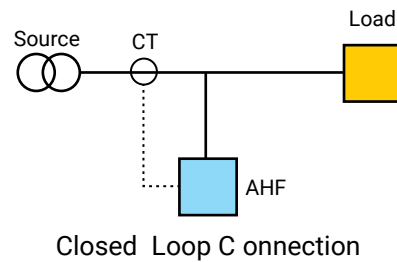

## Selection / Sizing of Nominal Current of AHF

Active harmonic filter is rated in Amperes. The current rating is decided on the basis of harmonic content (THD) in the system which can be obtained from harmonic study. The required

nominal current can be obtained by multiplying the initial current of harmonics measured in the load by a safety factor ( $SF_h$ ) of 20%. In other words,

$$I_{\text{filter}} (\text{AHF}) = 1.2 \times I_{\text{load}} \times \% \text{THD} (I)$$

Where,

- $I_{\text{filter}} (\text{AHF})$  : Nominal Current of Active Filter (A)
- $I_{\text{load}}$  : Maximum Load Current (A)
- $\% \text{THD}(I)$  : Load Current Harmonic Distortion (%)

Majority of the energy saving devices are non-linear in nature. Consequently, the problem of harmonics has become inevitable. Advanced devices like active harmonic filter

provide an ideal solution to this problem. These filters help in maintaining a stable and healthy power system thereby increasing productivity and efficiency.

## Function

Active Harmonic filters are the most ideal solution for power quality problems caused, in either industrial or commercial

facilities, for harmonic filtering, phase balancing and reactive power compensation.



### › Harmonic Filtering:

The filters reduce harmonics up to the 50th order (2500 Hz) reducing distortion power factor. Selection of specific harmonic order for filtering helps in optimizing filtering efficiency.

3 Phase 4 Wire filter configuration ensures reduction in neutral current that can reach up to 200% of rated value due to triple-N harmonics.

| THD TOTAL |      |       |
|-----------|------|-------|
|           | LOAD | MAINS |
| L1        | 21%  | 5%    |
| L2        | 18%  | 5%    |
| L3        | 19%  | 5%    |

### › Phase Unbalance Correction:

This function ensures balanced current on the supply side in 3 Phase 4 Wire filter configuration.

| VOLTAGE & CURRENT |         |         |       |
|-------------------|---------|---------|-------|
|                   | VOLTAGE | CURRENT |       |
|                   |         | LOAD    | MAINS |
| L1                | 232 V   | 199 A   | 220 A |
| L2                | 231 V   | 206 A   | 221 A |
| L3                | 231 V   | 255 A   | 221 A |
| FREQUENCY         |         | 50 Hz   |       |

### Phase Balancing

### › Power Factor Correction:

This filter ensures close to unity displacement power factor for both lagging (inductive) and leading (capacitive) current systems. With improvement in both distortion and displacement power factor, true power factor is also improved.

| POWER MAINS |         |           |           |      |
|-------------|---------|-----------|-----------|------|
|             | P       | Q         | S         | PF   |
| L1          | 41.6 kW | 5.92 kVAr | 42.02 kVA | 0.99 |
| L2          | 38.9 kW | 5.52 kVAr | 39.29 kVA | 0.99 |
| L3          | 231 V   | 6.80 kVAr | 48.48 kVA | 0.99 |

### Reactive Power Compensation

| Features  | Advantages   | Benefits  |
|---|--|---|
| Employs floating Point 32 bit Digital Signal Processor                                    | High accuracy & high attenuation up to 96% of individual harmonics | Effective harmonic Mitigation as per IEEE - 519                                     |
| Programmable selective harmonic elimination   |  |   |
| Multiple Units can be connected in parallel   | Modularity & expandability   | Reduced Mean Time to Repair; Filter can be expanded as per future load requirements |
| Employs high speed IGBTs in power circuit   | Faster response to change in THD and very high speed of operation  | THD can be maintained even in case of very frequently changing load                 |
| Provision of Alarms   | Easy diagnosis of fault conditions                                 | Safety to devices and operators   |
| 7" TFT touch screen HMI   | Easy configuration and parameter monitoring                        | Ease of installation and maintenance, User-friendly                                 |
| Ethernet based communication  | Remote monitoring  | Ease of monitoring  |
| Configuration in both open loop (load side sensing) and closed loop (source side sensing) | Faster response & higher attenuation of harmonics                  | Flexibility of configuration  |

The active filter is ideal in any application that has a large variation of loads, a wide spectrum of harmonics that must be compensated. Non-linear loads that are heavily distributed in the form of small network loads, so that it is not possible to use individual passive filters.

The most common applications are:

- › Variable frequency drives
- › Computer loads
- › UPS
- › CFL Lamps



In other words, its application is in any industry where large non-linear loads are present with high THD. Such high THD are prevalent in the following industries:

- › Automotive Industry
- › Textile Industry
- › Cement Industry
- › Data Centres
- › Paper Mills
- › Oil & Gas Exploration
- › Wind Turbines
- › Sugar Plants
- › Water Treatment
- › Building & Infrastructure
- › Pharmaceutical Industry
- › Granite & Stone Polishing

## Connection Diagram

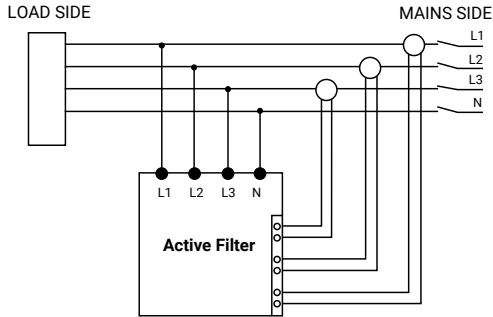

**Close Loop Connection**

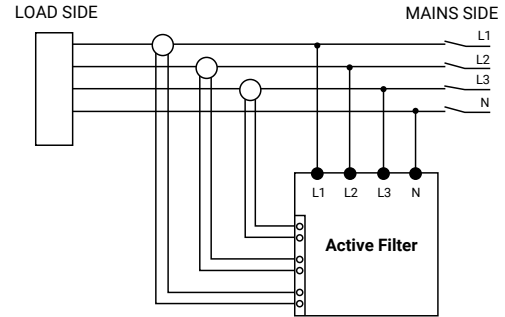

**Open Loop Connection**

## Technical Specifications

|  |   |         |      |       |       |              |         |       |       |       |       |       |       |        |  |
|--|---|---------|------|-------|-------|--------------|---------|-------|-------|-------|-------|-------|-------|--------|--|
| Model  | AHF - 3W/4W   |         |      |       |       |              |         |       |       |       |       |       |       |        |  |
| <b>INPUT</b>   |   |         |      |       |       |              |         |       |       |       |       |       |       |        |  |
| Input Voltage, Max/Min.  | 400 V AC +10%/-15%  |         |      |       |       |              |         |       |       |       |       |       |       |        |  |
| Current Rating   | 30 A  | 60 A    | 75 A | 100 A | 125 A | 150 A        | 200 A   | 250 A | 300 A | 400 A | 500 A | 600 A | 750 A | 1000 A |  |
| Frequency  | 50Hz,+/-5%  |         |      |       |       |              |         |       |       |       |       |       |       |        |  |
| Wiring configuration   | 3P3W/3P4W   |         |      |       |       |              |         |       |       |       | 3P3W  |       |       |        |  |
| <b>FILTER</b>  |   |         |      |       |       |              |         |       |       |       |       |       |       |        |  |
| Harmonic Range (2nd to 50th order)   | 2 <sup>nd</sup> to 50 <sup>th</sup> order   |         |      |       |       |              |         |       |       |       |       |       |       |        |  |
| Harmonic Selection (All/other selection)   | Any 20 can be selected at a time  |         |      |       |       |              |         |       |       |       |       |       |       |        |  |
| Harmonic Attenuation Ratio in %  | Up to 96% at rated current  |         |      |       |       |              |         |       |       |       |       |       |       |        |  |
| Response time  | < 1 ms  |         |      |       |       |              |         |       |       |       |       |       |       |        |  |
| Function Selection (Harmonic filtering, Power factor correction, Load balancing) | Harmonic filtering, Power factor correction, Load balancing   |         |      |       |       |              |         |       |       |       |       |       |       |        |  |
| Overload (peak value)  | 125% for 10 msec  |         |      |       |       |              |         |       |       |       |       |       |       |        |  |
| Interface (Communication)  | RS 485 MODBUS/MODBUS TCP/IP   |         |      |       |       |              |         |       |       |       |       |       |       |        |  |
| <b>PHYSICAL CHARACTERISTICS</b>  |   |         |      |       |       |              |         |       |       |       |       |       |       |        |  |
| Protection Class   | IP20, (IP40/IP42 Optional)  |         |      |       |       |              |         |       |       |       |       |       |       |        |  |
| Cooling  | Forced air  |         |      |       |       |              |         |       |       |       |       |       |       |        |  |
| Cable entry  | Bottom  |         |      |       |       | Top & Bottom |         |       |       |       |       |       |       |        |  |
| <b>ENVIRONMENTAL</b>   |   |         |      |       |       |              |         |       |       |       |       |       |       |        |  |
| Ambient Temperature  | 0 to 40° C  |         |      |       |       |              |         |       |       |       |       |       |       |        |  |
| Relative Humidity  | 95% (Non condensing)  |         |      |       |       |              |         |       |       |       |       |       |       |        |  |
| Maximum operating altitude without de-rating                                     | 1000 m  |         |      |       |       |              |         |       |       |       |       |       |       |        |  |
| Acoustic noise at 1m from Panel front (Ref ISO3746)                              | < 65 db   | < 68 db |      |       |       |              | < 70 db |       |       |       |       |       |       |        |  |
| <b>USER INTERFACE</b>  |   |         |      |       |       |              |         |       |       |       |       |       |       |        |  |
| User Parameter Setting   | TFT touch screen HMI  |         |      |       |       |              |         |       |       |       |       |       |       |        |  |
| <b>PROTECTION AND STANDARDS</b>  |   |         |      |       |       |              |         |       |       |       |       |       |       |        |  |
| Protections  | MCCB & fast acting semiconductor fuses  |         |      |       |       |              |         |       |       |       |       |       |       |        |  |
| Alarms   | DC over voltage, Over load trip, Over temperature alarm & trip, Over current, No synchronisation, Mains abnormal, DC under voltage, Active filter trip, Wrong phase, No faults, Fast DC overvoltage, Inductor over temperature trip |         |      |       |       |              |         |       |       |       |       |       |       |        |  |
| Reference Design Standard  | IEC 60146   |         |      |       |       |              |         |       |       |       |       |       |       |        |  |
| Safety Standard  | EN 50178  |         |      |       |       |              |         |       |       |       |       |       |       |        |  |
| Electromagnetic Compatibility  | EN 55011, IEC EN 50081-2, IEC 61000-4-2, IEC 61000-4-3, IEC 61000-4-4, IEC 61000-4-5, IEC 61000-4-6, IEC 61000-6-2  |         |      |       |       |              |         |       |       |       |       |       |       |        |  |

## Expandability & modularity

Expandability: Modules of 125, 150 & 250 A can be added in the below AHFs without replacing the existing panel

| AHF Rating | Module Rating | No. of Modules | Expandable to | Additional Module Rating | Additional No of Modules. |
|------------|---------------|----------------|---------------|--------------------------|---------------------------|
| 250        | 125           | 2              | 500           | 125                      | 2                         |
| 300        | 150           | 2              | 600           | 150                      | 2                         |
| 500        | 250           | 2              | 1000          | 250                      | 2                         |

**2. Paralleling:** The available rating of the filter can be increased by connecting number of units in parallel considering future load demands. A single CT can be used for connecting upto 4 units in parallel. Additional CTs must be installed if more than 4 AHFs are to be used in parallel configuration. Paralleling is possible in AHFs with the same rating of modules.

**3. Replaceability:** If any module becomes faulty during operation, it can be replaced by another module of similar rating without affecting the operation of the rest of the filter. This reduces the downtime of AHF.

## Overall Dimensions

### AHF - 3P3W & 3P4W 30/60/75/100/125/150

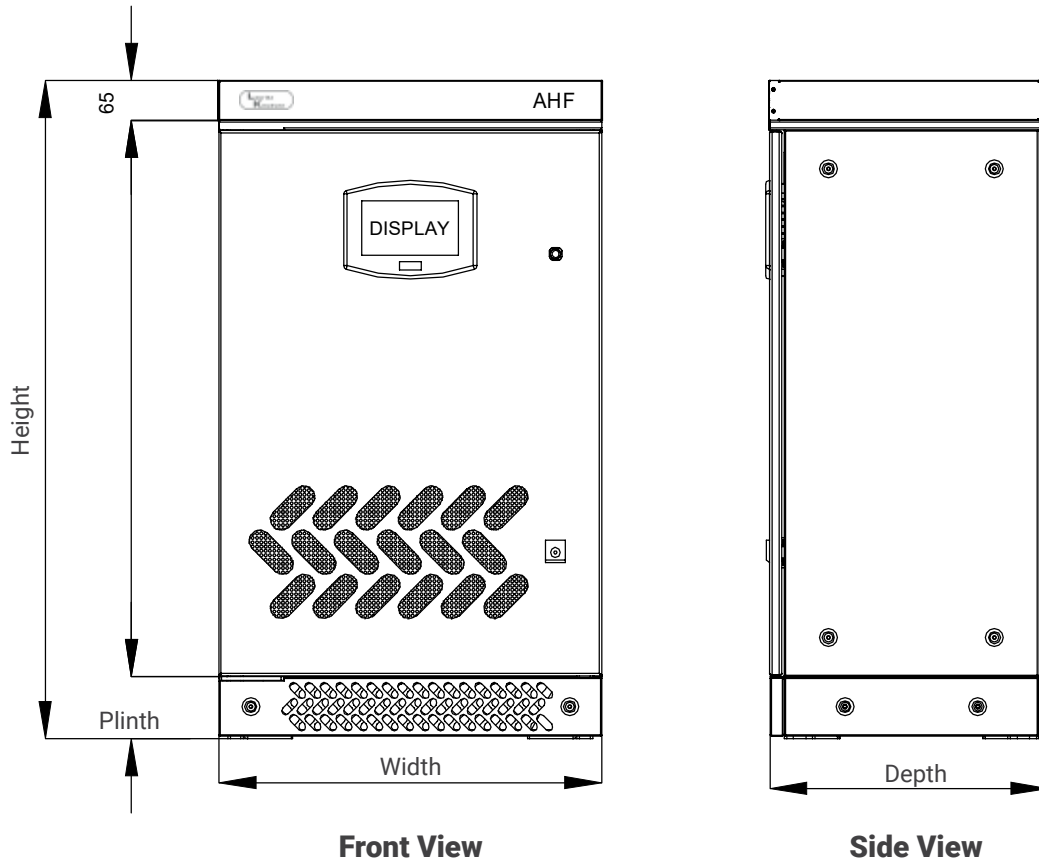

Front View

Side View

| 3 Ph 3 Wire / 4 Wire, 400 V Active Filter |                |  |                |       |        |        |
|---|----------------|--|----------------|-------|--------|--------|
| CAT No.                                   | Model No.      | Cable Size - Copper Single Core Flexible | Dimension (mm) |       |        |        |
|   |                |  | Width          | Depth | Height | Plinth |
| AHF030431D2                               | AHF - 3W- 30A  | 4 X 10 sq.mm (RYBN)                      | 620            | 450   | 1065   | 100    |
| AHF030441D2                               | AHF - 4W- 30A  | 6 X 10 sq.mm (RYB3N)                     |                |       |        |        |
| AHF060431D2                               | AHF - 3W- 60A  | 4 X 25 sq.mm (RYBN)                      | 620            | 450   | 1065   | 100    |
| AHF060441D2                               | AHF - 4W- 60A  | 6 X 25 sq.mm (RYB3N)                     |                |       |        |        |
| AHF075431D2                               | AHF - 3W- 75A  | 4 X 35 sq.mm (RYBN)                      | 620            | 450   | 1065   | 100    |
| AHF075441D2                               | AHF - 4W- 75A  | 6 X 35 sq.mm (RYB3N)                     |                |       |        |        |
| AHF100431D2                               | AHF - 3W- 100A | 4 X 50 sq.mm (RYBN)                      | 620            | 450   | 1065   | 100    |
| AHF100441D2                               | AHF - 4W- 100A | 6 X 50 sq.mm (RYB3N)                     |                |       |        |        |
| AHF125433D2                               | AHF - 3W- 125A | 4 X 70 sq.mm (RYBN)                      | 620            | 450   | 1165   | 100    |
| AHF125443D2                               | AHF - 4W- 125A | 6 X 70 sq.mm (RYB3N)                     |                |       |        |        |
| AHF150433D2                               | AHF - 3W- 150A | 4 X 70 sq.mm (RYBN)                      | 620            | 450   | 1165   | 100    |
| AHF150443D2                               | AHF - 4W- 150A | 6 X 70 sq.mm (RYB3N)                     |                |       |        |        |

## Overall Dimensions

AHF - 3P 3W & 4W 200/250/300/400 & AHF- 3P3W 500/600/750/1000

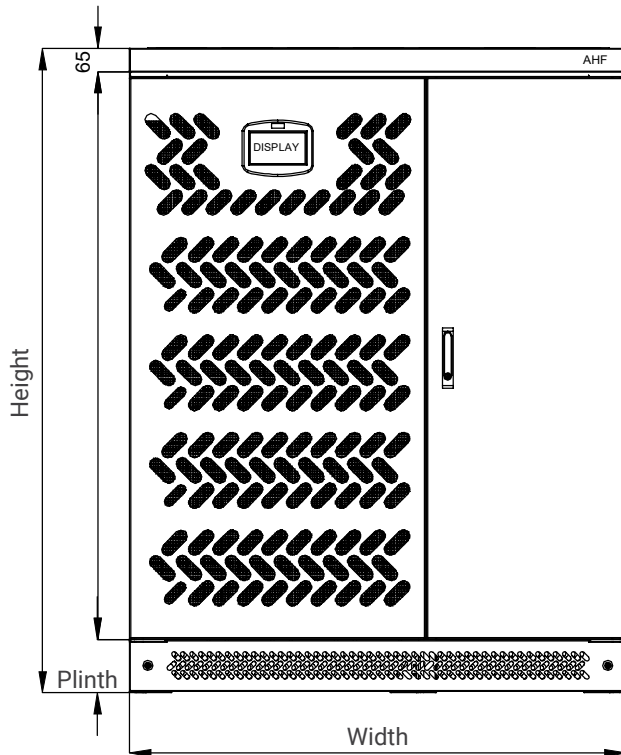

Front View

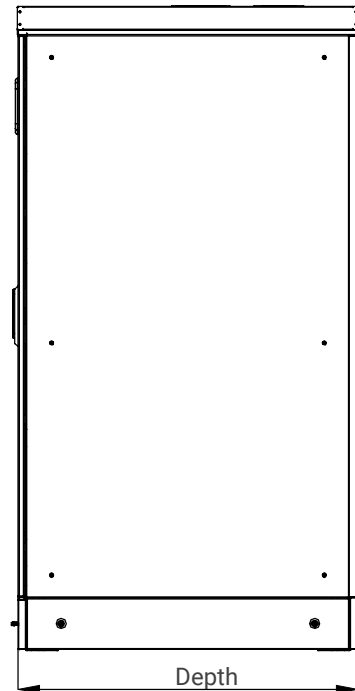

Side View

| 3 Ph 3 Wire / 4 Wire, 400 V Active Filter |                 |  |                |       |        |        |
|---|-----------------|--|----------------|-------|--------|--------|
| CAT No.                                   | Model No.       | Cable Size - Copper Single Core Flexible | Dimension (mm) |       |        |        |
|   |                 |  | Width          | Depth | Height | Plinth |
| AHF200433D2                               | AHF - 3W- 200A  | 4 X 70 sq.mm (RYBN)                      | 1000           | 850   | 1665   | 150    |
| AHF200443D2                               | AHF - 4W- 200A  | 6 X 70 sq.mm (RYB3N)                     |                |       |        |        |
| AHF250433D2                               | AHF - 3W- 250A  | 4 X 120 sq.mm (RYBN)                     | 1000           | 850   | 1665   | 150    |
| AHF250443D2                               | AHF - 4W- 250A  | 6 X 120 sq.mm (RYB3N)                    |                |       |        |        |
| AHF300433D2                               | AHF - 3W- 300A  | 4 X 120 sq.mm (RYBN)                     | 1000           | 850   | 1665   | 150    |
| AHF300443D2                               | AHF - 4W- 300A  | 6 X 120 sq.mm (RYB3N)                    |                |       |        |        |
| AHF400433D2                               | AHF - 3W- 400A  | 4 X (2 X 70) sq.mm (RYBN)                | 1000           | 850   | 1665   | 150    |
| AHF400443D2                               | AHF - 4W- 400A  | 6 X (2 X 70) sq.mm (RYB3N)               |                |       |        |        |
| AHF500433D2                               | AHF - 3W- 500A  | 4 X (2 X 100) sq.mm (RYBN)               | 1000           | 850   | 1665   | 150    |
| AHF600433D2                               | AHF - 3W- 600A  | 4 X (2 X 120) sq.mm (RYBN)               | 1000           | 850   | 1665   | 150    |
| AHF750433D2                               | AHF - 3W- 750A  | 4 X (2 X 140) sq.mm (RYBN)               | 1400           | 960   | 1665   | 150    |
| AHF000433D2                               | AHF - 3W- 1000A | 4 X (2 X 140) sq.mm (RYBN)               | 1400           | 960   | 1665   | 150    |

# Power Factor Perfected, Harmonics Mitigated

## ASVG & AHF

Experience the next generation of power quality solutions. Our Advanced Static VAR Generator (ASVG) & Active Harmonic Filter (AHF) Modules dynamically corrects power factor for varying loads and mitigates harmonic in the system, resulting in improved system performance and a longer equipment lifespan. ASVG & AHF Modules compatibility with Hybrid controller enables true hybrid solutions, offering greater control and flexibility.



Ultra-High Speed  
compensation using IGBT



Dynamic Stepless Power  
Factor Correction



Harmonic  
Mitigation

### ACTIVE HARMONIC FILTER - MODULE

#### Features

- › Reduces THD within IEEE - 519 limits
- › Harmonic Mitigation, Dynamic Stepless PF correction & Load balancing
- › Advanced 3 Level Inverter topology
- › Harmonic Mitigation up to 51st Order
- › Fast response time of 50  $\mu$ sec
- › Lower thermal losses
- › Scalable architecture for future expansion
- › Communicable – Inbuilt MODBUS RS485 Protocol
- › Wall mount/ Rack Mount Modules
- › True Hybrid Solution Compatibility

# AHF Modules

Conventional Active Harmonic Filter systems are typically implemented as large panels connected in parallel with the load. While these systems offer effective harmonic mitigation, their physical footprint can be a limiting factor in installations with restricted space availability. To address this challenge, AHF Modules have been engineered as compact, scalable components that can be incorporated within various electrical distribution panels. These modules maintain the full functionality of traditional AHF systems while offering a significantly reduced form factor. Their modular architecture helps to build more tailored and space-efficient solutions.



## Features and Customer Benefits

| Feature   | Advantage  | Benefits   |
|---|--|--|
| 3 Level inverter Topology   | less ripple in output waveform                       | lower losses there by higher efficiency  |
| Any number of units of different ratings can be connected in parallel                     | Modularity & expandability                           | Total Capacity can be expanded as per future load requirements                                 |
| 4.3"/ 7" TFT touch screen HMI   | Easy configuration and parameter monitoring          | Real time monitoring of essential Power Quality parameters                                     |
| Configuration in both open loop (load side sensing) and closed loop (source side sensing) | Flexibility in CT connection                         | CT can be mount on any side, which reduces the complexity in Ct installation                   |
| Smaller Footprint   | Easy to handle & install                             | Require less space and easy to integrate with APFC/RTPFC or any other OEM panel.               |
| CT polarity Change from HMI   | CT Polarity & Phase sequence can be changed from HMI | Faster Installation & Commissioning.   |
| Withstand high Voltage harmonic environment   | Withstand up to 15% VTHD                             | Withstand in High Harmonic network.  |
| Inbuilt Semiconductor fuse and SPD  | Better module Protection                             | Offer better protection to module and reduces repair & replacement Cost.                       |
| Hybrid Controller   | Integration with existing/new APFC & RTPFC           | Single controller, capable of controlling both Passive as well as Active part of hybrid system |

## Technical Specifications

| Sr.No.                           | INPUT  |  |        |         |
|----------------------------------|--|--|--------|---------|
| 1                                | System input   | 3Ph 3Wire/4 Wire   |        |         |
| 2                                | Input Voltage  | 415 V<br>3P4W (+10%, -25%)<br>3P3W (+15%, -25%)                            |        |         |
| 3                                | Ratings  | 30 AMP   | 50 AMP | 100 AMP |
| 4                                | Frequency  | 50Hz,+/-5%   |        |         |
| <b>FILTER</b>                    |  |  |        |         |
| 5                                | Harmonic Mitigation Range  | 2nd to 51st Order  |        |         |
| 6                                | Inverter technology (Three level/two level topology, IGBT )                      | Three level  |        |         |
| 7                                | Efficiency   | > 97%  |        |         |
| 8                                | Response time  | < 50µs   |        |         |
| 9                                | Correction Time  | < 1 Power Cycle  |        |         |
| 10                               | Function Selection (Harmonic filtering, Power factor correction, Load balancing) | Harmonic Mitigation, PF Correction & Unbalance correction                  |        |         |
| 11                               | Current Transformer  | Sec 5 A, Class 1, 15VA rating  |        |         |
| <b>PHYSICAL CHARACTERISTICS</b>  |  |  |        |         |
| 12                               | Design (Modular/Non Modular)   | Modular  |        |         |
| 13                               | Mounting   | Wall mount/ Rack type  |        |         |
| 14                               | Protection Class   | IP20   |        |         |
| 15                               | Cooling  | Forced air   |        |         |
| <b>ENVIRONMENTAL</b>             |  |  |        |         |
| 16                               | Ambient Temperature  | -10 to 45 Deg C  |        |         |
| 17                               | Relative Humidity  | 95% (Noncondensing)  |        |         |
| 18                               | Maximum operating altitude without de-rating                                     | < 2000 m   |        |         |
| 19                               | Noise Level  | <65dB  |        |         |
| <b>USER INTERFACE</b>            |  |  |        |         |
| 20                               | HMI  | Wall Mount - Inbuilt 4.3 Inch<br>Rack Mount - External 7-inch HMI Required |        |         |
| 21                               | Hybrid controller  | Yes, Optional (with Transistor / Relay)                                    |        |         |
| 22                               | Interface (Communication)  | MODBUS-RTU   |        |         |
| <b>PROTECTIONS AND STANDARDS</b> |  |  |        |         |
| 23                               | Protections  | Fast acting semiconductor fuses & SPD                                      |        |         |
| 24                               | Overvoltage & undervoltage protection  | Available  |        |         |
| 25                               | Overheating protection   | Available  |        |         |
| 26                               | Overcompensation protection  | Available  |        |         |
| 27                               | Inverter Bridge inverse protection   | Available  |        |         |
| 28                               | Safety Standard  | EN 50178:1997/ IEC 50178:1997  |        |         |

## AHF Module Dimensions

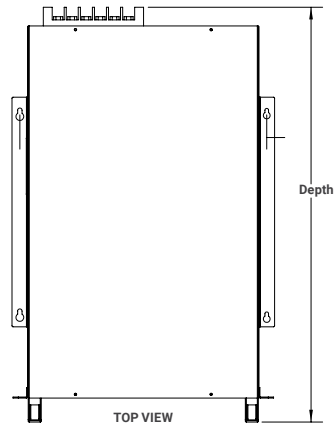
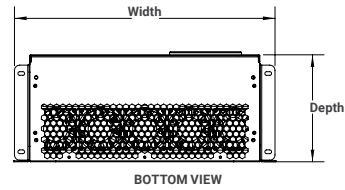
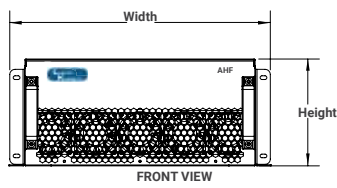

Rack Mount Module

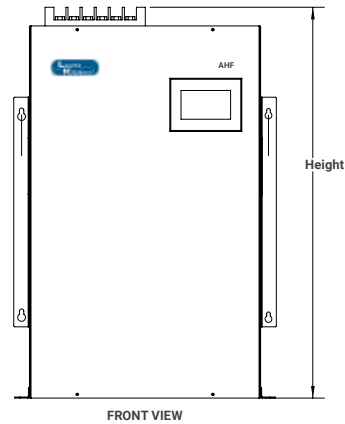

Wall Mount Module

| 3 Ph 3 Wire / 4 Wire, 415V AHF Module |                          |  |                |       |        |
|---------------------------------------|--------------------------|--|----------------|-------|--------|
| CAT No.                               | Model No.                | Cable Size - Copper Single Core Flexible | Dimension (mm) |       |        |
|                                       |                          |  | Width          | Depth | Height |
| AHF0030H3WD2                          | AHF - 3W- 30 KVAR, Wall  | 3 X 16 sq.mm (RYB)                       | 500            | 212   | 559    |
| AHF0030H4WD2                          | AHF - 4W- 30 KVAR, Wall  | 4 X 16 sq.mm (RYBN)                      |                |       |        |
| AHF0030N3RD2                          | AHF - 3W- 30 KVAR, Rack  | 3 X 16 sq.mm (RYB)                       | 500            | 605   | 212    |
| AHF0030N4RD2                          | AHF - 4W- 30 KVAR, Rack  | 4 X 16 sq.mm (RYBN)                      |                |       |        |
| AHF0050H3WD2                          | AHF - 3W- 50 KVAR, Wall  | 3 X 35 sq.mm (RYB)                       | 500            | 200   | 666    |
| AHF0050H4WD2                          | AHF - 4W- 50 KVAR, Wall  | 4 X 35 sq.mm (RYBN)                      |                |       |        |
| AHF0050N3RD2                          | AHF - 3W- 50 KVAR, Rack  | 3 X 35 sq.mm (RYB)                       | 500            | 712   | 200    |
| AHF0050N4RD2                          | AHF - 4W- 50 KVAR, Rack  | 4 X 35 sq.mm (RYBN)                      |                |       |        |
| AHF0100H3WD2                          | AHF - 3W- 100 KVAR, Wall | 3 X 70 sq.mm (RYB)                       | 500            | 204   | 749    |
| AHF0100H4WD2                          | AHF - 4W- 100 KVAR, Wall | 4 X 70 sq.mm (RYBN)                      |                |       |        |
| AHF0100N3RD2                          | AHF - 3W- 100 KVAR, Rack | 3 X 70 sq.mm (RYB)                       | 500            | 795   | 204    |
| AHF0100N4RD2                          | AHF - 4W- 100 KVAR, Rack | 4 X 70 sq.mm (RYBN)                      |                |       |        |

# Harmonics and its Impacts on Power Factor

## Defining Power Factor

Power factor is usually identified as the cosine of angle between the voltage sine wave and the current sine wave. For a better understanding, it can be seen as the efficiency of electricity consumption. Similar to the efficiency of a machine, it can be defined as the ratio of output power rendered by the machine to the machine input power. Hence, it is the ratio of True power (kW) to Apparent Power (kVA).

$$\text{Power factor (PF)} = \frac{\text{kW}}{\text{kVA}}$$

However, it is not the only power factor present in the system. Depending on which value of voltage and current we consider, there are different types of power factors:

- Displacement PF
- Distortion PF
- True PF

## Types of Power Factor

**1. Displacement PF** – The power factor which is due to the phase shift between voltage and current at the fundamental frequency is known as displacement power factor.

$$\text{Displacement PF} = \frac{P}{V_1 I_1}$$

**2. Distortion PF** – The power factor which includes the effect of harmonics present in the system is called distortion power factor.

$$\text{Distortion PF} = \frac{1}{\sqrt{1 + \%i\text{THD}^2}}$$

**3. True PF** – It is defined as the ratio of average power to apparent power. Both the above power factors together combine to form the True power factor.

True PF = Displacement PF x Distortion PF

$$\text{True PF} = \frac{P}{V_{\text{rms}} I_{\text{rms}}}$$

## Different types, different implications

Understanding the various types of power factor is very important because all three have different implications.

When we talk about power factor correction by means of capacitors, we are referring to improvement of only the displacement power factor, which consequently improves the true power factor. Capacitors act like an alternate source of reactive power and hence by decreasing the inductiveness of the system, they reduce the lag between the current and voltage phase, thus improving the power factor. But it is important to note that these voltage and current waves are with respect to the fundamental component i.e. 50 Hz. There might be some cases where even after installing capacitors at site, the power factor doesn't improve. Here distortion power factor comes into picture. Under normal load conditions,

$$\text{kVA} = \frac{\text{kW}}{\text{PF}}$$

Here, the system current is the rms current at 50 Hz.

For pure sinusoidal cases (systems without Harmonics),

$$\text{PF}_{\text{true}} = \text{PF}_{\text{disp}} = \text{COS}\phi$$

where  $\phi$  is the angle between voltage and current wave. In case of a system with Non Linear loads, when the system is polluted by harmonics, the rms current increases as seen by the following formula –

$$I = I_1 \sqrt{1 + i\text{THD}^2}$$

Increase in rms current consequently leads to increase in kVA demand. But the kW output of the system would remain the same.

$$\text{Following the formula } \text{kVA} = \frac{\text{kW}}{\text{PF}}$$

If kVA demand increases with kW remaining constant, power factor has to decrease. This decrease in power factor due to the presence of harmonics can be attributed to the 'distortion power factor'. Here true power factor becomes a product of displacement and distortion power factor. Hence, even if the displacement pf is corrected up to unity, the true pf will still remain low because of poor distortion PF.

Mathematically, distortion pf can be calculated as:

$$\text{PF}_{\text{dist}} = \frac{1}{\sqrt{1 + i\text{THD}^2}} = \frac{I_1}{I_{\text{rms}}}$$

where  $I_1$  is the rms value of the fundamental current and  $I_{\text{rms}}$  is the rms value of total current.

Harmonic levels are measured as Total Harmonic Distortion (THD). Higher THD implies lower distortion PF. The graph below depicts the impact of THD levels on the true power factor of non linear loads.

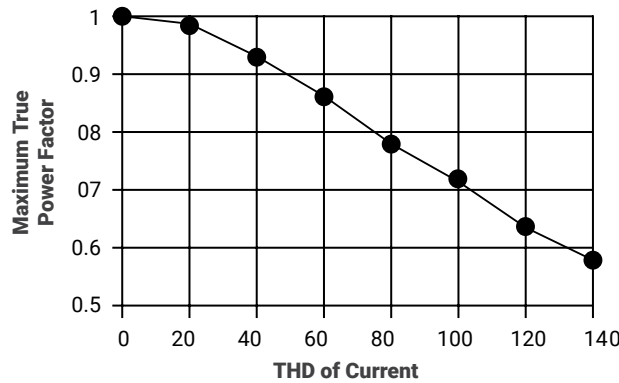

The following table shows how different types of power factor vary with THD.

| THD-I | Displacement pf<br>(assumed to be compensated<br>by equivalent Capacitors) | Distortion pf | True pf |
|-------|--|---------------|---------|
| 5%    | 0.999  | 0.999         | 0.998   |
| 30%   | 0.999  | 0.958         | 0.957   |
| 40%   | 0.999  | 0.929         | 0.928   |

Capacitors don't do any good in correcting distortion power factor. In harmonic rich environment, using capacitors can even be detrimental to the installation as it can lead to harmonic resonance and harmonic amplification. Hence, in such cases, we need to use detuned reactors along with capacitors to avoid amplification.

**The smart choice**

For improving true power factor, correction of both displacement and distortion power factor is required. Capacitors are the means for improving solely the displacement power factor. But we can't overlook the repercussions of using capacitors

APFC panels with detuned filters can effectively increase the displacement pf to unity. But the distortion pf will still remain low due to the presence of harmonics in the system. And hence, the true power factor will remain low, as seen in the above table. Thus, to improve distortion pf, Active Harmonic Filter should be used to mitigate harmonics.

alone in systems with high harmonics. In a harmonics rich environment, Active Harmonic Filter must be used to improve distortion pf. Hence, for power factor correction, hybrid filter (capacitor-reactor combination with AHF) is the smart choice.

# Impact of Harmonics on DG sets

## Difference between Diesel Generator Sets and Power Grid

The electrical grid is an enormous source of power and can be referred to as infinite bus. There are innumerable loads connected to the grid and a change in any of those loads accounts to only a small fraction of the total grid capacity. The effect of load changes are less on the grid, in terms of stability of supply voltage. It can be called a 'stiff' power source or having high inertia. Diesel generators (DG) sets, however, are used as a backup supply or even permanent power source in some systems. As any change in load connected to the DG set accounts for a considerable percentage of its total capacity, it can easily affect its output voltage. DG responds to any small change in current demand immediately, even at the expense of output voltage. It means DG set has low inertia and can be called 'soft' power source.

Another difference between grid and Diesel Generator sets is that DG sets have a very high source impedance that can be as high as 25-30%, as compared to transformer impedance of 3-5%. Hence, the short circuit breaking capacity of the Short Circuit Protection device (SCPD) used under the grid is higher as compared to SCPD used for loads connected with a DG set. It is important to note that harmonic distortion is a function of source impedance. As the steady state impedance in case of DG set is very high, presence of even small amount of I-THD creates large V-THD when it travels through the high impedance.

Let us consider an example with a total load current of 1000 A in which 700 A is the nonlinear current. Here, nonlinear loads are drives with harmonics of say 55%

$$I\text{-THD} = \frac{0.55 \times 700}{1000} \times 100 = 38.5\%$$

V-THD can be calculated considering transformer impedance of 5% in case of grid and DG impedance of 30% in case of Diesel Generator.

For the said % I-THD, approximate values of % V-THD are indicated as follows:

| Source (%Z)            | % I-THD | % V-THD |
|------------------------|---------|---------|
| Electricity Grid (5%)  | 38.5    | 1.92    |
| Diesel Generator (30%) | 38.5    | 11.5    |

Therefore, it can be clearly seen that due to higher source impedance in case of DG set, the same I-THD leads to a higher levels of V-THD.

Due to the differences in the two sources, DG sets behave differently in presence of harmonics. This section discusses about the impact of harmonics on Diesel Generators and the ways to mitigate the effects.

## Impact of harmonics on Diesel Generators

Some important effects in Diesel Generators in the presence of harmonics are:

### 1) Flat topping

As discussed at the outset, Diesel generator is a soft source, which means it cannot sustain sudden changes in load very well. Majority of the non-linear loads in industries are variable frequency drives (VFD), which consist of a rectifier, a DC bus and an inverter. The capacitors of VFD's DC bus pull the current when the incoming sine wave voltage is higher than the DC bus capacitor voltage, which happens near the peak of the incoming AC Voltage. When the total VFD loads account for a significant percentage of the genset capacity, such current drawn at the peaks will cause a sudden increase in demand from the DG. The DG being a "soft" source responds to this current demand immediately at the cost of output voltage. The voltage at DG output will drop. The AVR starts regulating and brings the voltage to the required level. But before the instant when voltage reaches the required level, the DG voltage is already clipped, this is called "flat topping". The voltage waveform occurs to be flat as seen in the following graphs:

### Lightly loaded generator

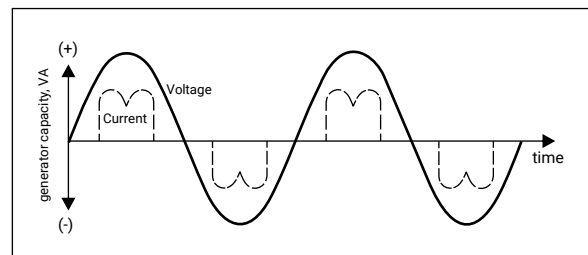

### Loaded generator

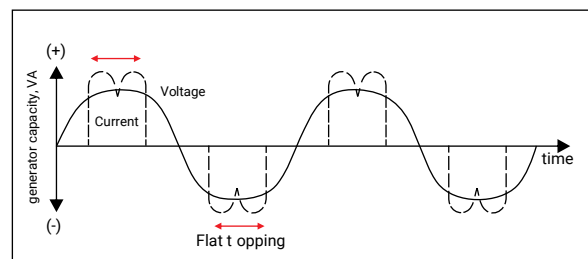

As can be seen from the graphs, flat topping of the voltage waveforms increases with the increase in generator loading. Flat topping can reduce the actual system peak to peak voltage to levels as low as 70% of the RMS voltage. This reduction creates an excessive flow of current through the system which can lead to burn out of machines.

## 2) Automatic Voltage Regulator malfunction

Presence of voltage distortions implies defective functioning of one of the most critical equipment for a generator, which is the Automatic Voltage Regulator (AVR). AVR senses any change in the voltage levels due to changes in load and adjusts the excitation of the generator accordingly to maintain the same level of voltage output. In the presence of nonlinear loads, distortion in voltage supply and flat topping adds additional burden to the Automatic Voltage regulator (AVR) of the genset as it tries to compensate the voltage drop by increasing the voltage. In the presence of harmonics, the AVR won't be able to sense the voltage changes accurately due to highly distorted voltage wave. As the excitation won't be as per the correct requirement, the output voltage of the generator would suffer which leads to instability.

## 3) Losses and overheating

Diesel Generator includes an IC Engine working as the prime mover for the generator. Engine generates a lot of heat, which gets amplified in the enclosed environment of the Genset. Hence, heating in Diesel Generators is a bigger issue as compared to heating in transformers. Harmonics being high in frequency cause high frequency flux change in the stator leading to heating of the stator core. Increased current in the system also lead to copper losses in the armature, which in turn lead to further overheating. High harmonic currents also lead to eddy current losses in the rotor. Increased losses of various kinds degenerates the machine efficiency and life. Other effects include skin effect and insulation failure.

## 4) Vibrations

Certain Harmonic currents which have a negative phase sequence, on interacting with the magnetic field generate torque in opposition to the machine rotating torque. A resultant pulsating torque is generated which leads to vibrations in the machine. It is detrimental to the machine life.

**Impact of Harmonics on sizing of Diesel Generators** Generator manufacturers recommend derating the Diesel Generator in presence of harmonics in such a way that the total non-linear loads under a genset should be less than 40% of its total capacity (as recommended by most genset manufacturers; may change from manufacturer to manufacturer). For better understanding, consider the following example.

**Case 1:** Suppose the DG rating is 1000 kVA Total current =  $(1000 \times \text{kVA}) / (\sqrt{3} \times V) = (1000 \times 100) / (\sqrt{3} \times 440) = 1312.16 \text{ A}$

Hence, total nonlinear current should be less than  $0.40 \times 1312.16 = 524.86 \text{ A}$

**Case 2:** If the nonlinear current increases in the system as a result of increased drive loads to say 700A

Then the DG should be sized as per current of  $(700 \times 100) / 40 = 1750 \text{ A}$

DG in this case should be rated at  $(\sqrt{3} \times V \times I) / 1000 = (\sqrt{3} \times 440 \times 1750) / 1000 = 1330 \text{ kVA}$

**Result:** In this case, increase in nonlinear loads has increased the size of the generator by 25%.

## Mitigation of Harmonics in Diesel Generators and PF correction

Derating the DG set is not a permanent solution. Increasing the DG size leads to increased costs and increased fuel consumption. This remedy is neither feasible nor economical.

To avoid malfunctioning of AVR under high harmonic levels, a harmonic filter can be incorporated in its sensing circuitry, but this option is quite expensive and doesn't deal with the presence of harmonics.

Many DG manufacturers do not recommend the use of capacitor banks with DG. Even when capacitor banks are used to maintain the power factor of 0.8, which is the optimum power factor for majority of DGs, presence of harmonics in the system will lead to premature failure of capacitors. Life of capacitors connected to DG set would be less than life obtained when they are connected to the grid for the same current harmonics level (this is due to higher voltage harmonics at the same given current harmonics).

In order to limit the levels of distortion, detuned filters can be used along with 525 V capacitors for preventing harmonic amplification. But as V-THD is high in this case, use of normal reactors is not recommended as there are high chances of reactor burnout. In such systems with high harmonic distortion, special reactors for high V-THD withstand should be used. Best solution for getting rid of the effects of harmonics in systems with DG is by eliminating the harmonics using an Active Harmonic Filter. Active filter senses the exact amount of harmonic levels in the system and eliminate their presence by pumping anti-harmonics.

It is important to note that as soon as we connect AHF near to the load, the load which was earlier seeing the high source impedance due to DG set will now see a very low impedance due to AHF. Hence, there would be high I-THD circulating between the AHF and the load. In such a case the sizing of the AHF needs to be done considering a higher safety factor. Sizing of AHF under a transformer is done with a safety factor of 20%, whereas for AHF under DG systems, a safety factor of 35% should be considered.

$$\text{AHF rating (A)} = 1.35 \times \text{load} \times \% \text{ I-THD}$$

In conclusion, where high V-THD and I-THD are expected, as in case of DG sets, Active Harmonic Filter would be the best solution. For cases which also aim at PF improvement, combination of 525 V MPP Capacitors and reactors with high V-THD withstand capability is recommended.



# Advance Static VAR Generator (ASVG)

Recently, a growing number of Utilities in India have been transitioning to the kVAh billing method. Furthermore, numerous Utilities provide incentives or rebates for improving Power Factor. Consumers desire Unity Power Factor to reduce their Electric bill costs. Usually, APFC panels using Contactor or Thyristor switches are utilized to achieve desired Power Factor. In some critical & special applications, the loads exhibit significant fluctuations (such as welding, inching, etc.). The unbalanced load also demands unbalanced Reactive Power. It will be difficult for the traditional APFC panel to respond to the highly fluctuating & unbalanced Reactive Power demand by the load. Static VAR Generator (SVG) can help in resolving such complex Reactive Power demands – be it fluctuating or unbalanced.

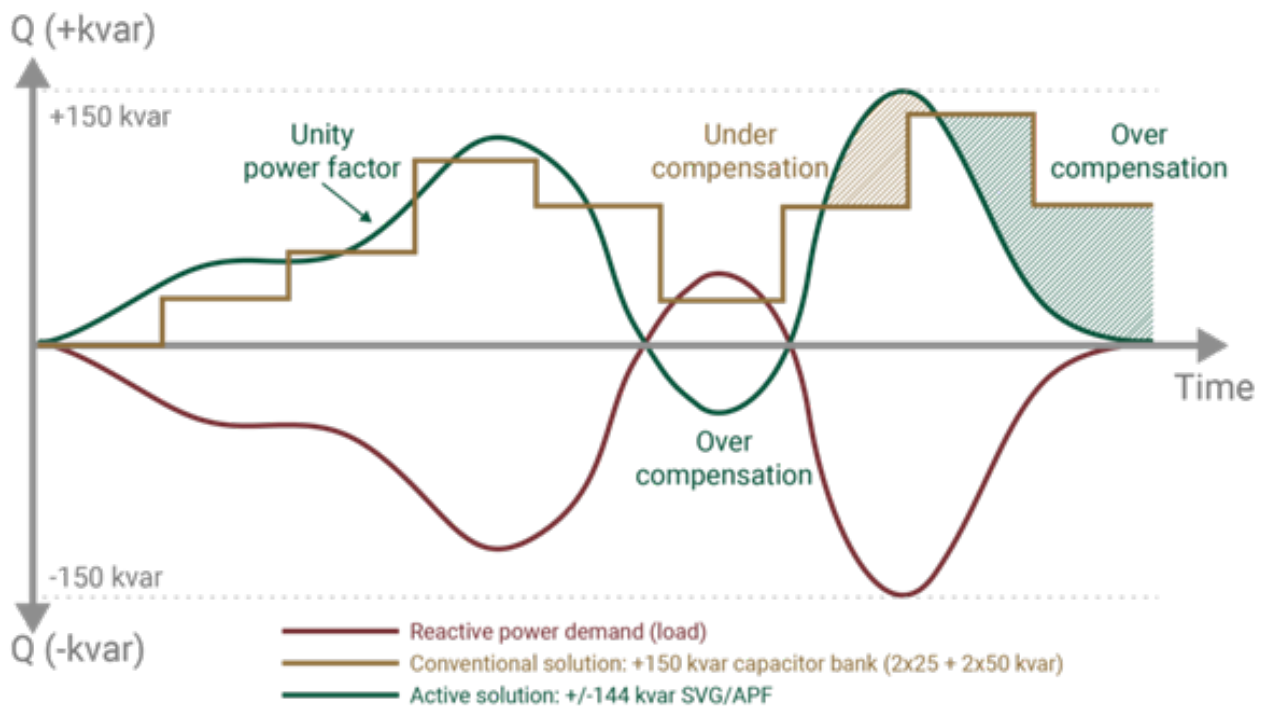

ASVG is IGBT based Active Power Factor Correction device, which can help in instantaneous, real-time step-less & unbalanced Power Factor correction along with mitigation of harmonics up to 15th order.

ASVG excels in maintaining the target PF accurately. The Reactive Power produced by the SVG (yellow graph) aligns with the load demand (green line) as depicted in the image above.

## Principle of Operation

The principle of operation of ASVG is very similar to Active Harmonic Filters – sensing the actual reactive power requirement

with CTs and the main DSP control card in the ASVG will decide how much counter reactive power is needed at that instant.

ASVG stands out for its ability to reduce lower order harmonics in addition to correcting power factor.

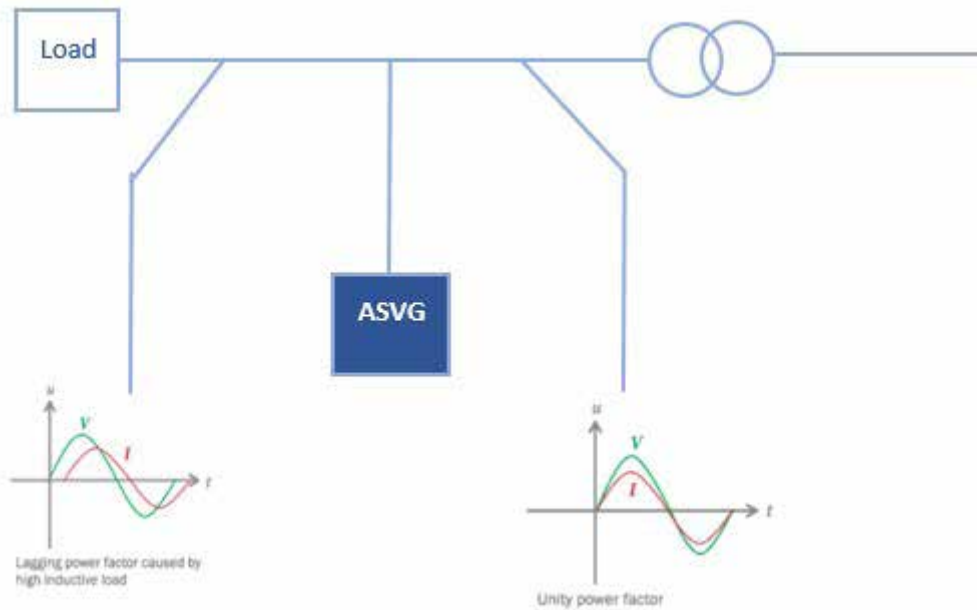

## Features

- › Instantaneous, precise & step-less power factor correction of both inductive (lagging) and capacitive (leading) loads
- › Available in 50 and 100 kVAr and up to 8 units of any size can be added-up in parallel.
- › Harmonics mitigation up to 15th order, including Triple-N harmonics.
- › Load balancing and unbalanced PF correction possible
- › 3-level NPC inverter topology reduces losses, noise, size and extends lifetime.
- › Overall response time < 1 cycle ensures accurate & instant PF correction
- › Harmonic resonance can be avoided
- › Hybrid ASVG - Capability of switching up to 18 contactors/ Thyristors of detuned filter capacitor bank steps.
- › Compact and modular design optimised for easy installation, commissioning, and maintenance.
- › Communication capability
- › Simple connection – both open loop and closed loop connections possible.

## Some of the areas where ASVG can be used are:

- › In Industries with requirement of fast correction of reactive power like welding machines, re rolling mills. This may have immediate adverse impacts like poor power factor there by higher unit consumption (KVAh). ASVG prove to be suitable as it provides real-time power factor correction and mitigation of predominant harmonic orders (Up to 15<sup>th</sup> order).
- › Certain segments with majority of single phase & two-phase loads causes Avg power factor to be on poor side, resulting in substantial loss due to increased KVAh consumption. ASVG is capable of providing unsymmetrical reactive power compensation and also, provide load balancing.
- › ASVG can be a standalone system or a part of hybrid system i.e. APFC/RTPFC + ASVG
- › The best part is the ASVG can work along with Traditional APFC/RTPFC panels in Hybrid mode, so that for base and less fluctuating loads, APFC/RTPFC will take care and for fluctuating / unbalanced loads & lower order harmonics, ASVG will compensate. This helps in perfect Hybrid Solution with optimal life cycle cost.

## Applications

- › Steel Industry
- › Mining & metal Industry
- › Automotive Industry
- › IT/ITES, Datacentres
- › Stone Crusher
- › Textile Industry
- › Chemical/petrochemical
- › Building Segment (Hospital, Hospitality)
- › Renewable energy
- › Process Industry

## Connections & CT installations of ASVG

For the stable operation of ASVG and for the expected improvement in PF & reduction of harmonics, the physical connection & location of power cables & CTs plays a critical role. Let us understand the connections through the below two cases.

**Case 1:** In case any industry faces severe problems due to not able to maintain the PF & harmonics levels in the facility, it is advisable to connect ASVG at Main Incomer to respond to faster correction requirement.

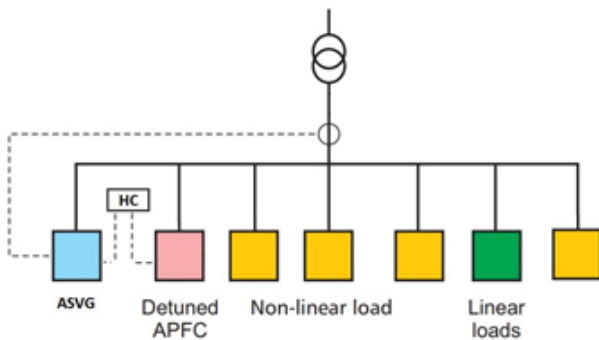

**Case 2:** To improve the power factor by compensating the transformer & cable losses, compensate the cable capacitance, a common ASVG can be connected for PF correction as shown below (HT Sensing):

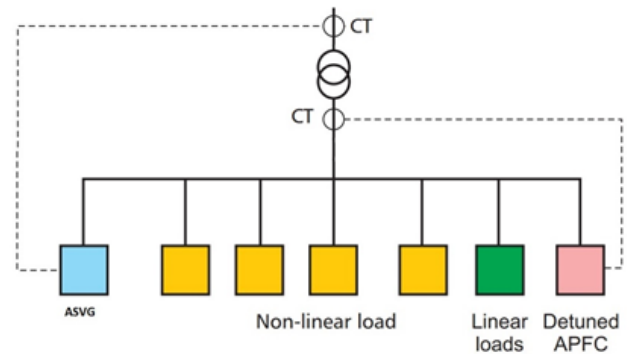

## Selection / Sizing of ASVG

ASVG is rated in KVAR. The KVAR rating is decided on the basis of requirement of Reactive Power (KVAR), Harmonic content (THD) & Unbalance in the system (UB) in the system which can be obtained from Power quality Analysis. The required KVAR can be obtained by following equation,

$$\text{KVAR} = (\sqrt{I_Q^2 + I_H^2 + I_B^2}) / 1.4$$

**Note:** 1kVar = 1.4 Amp at 415 V

Where,  
 $I_Q$  = Reactive Current  
 $I_H$  = Harmonic Current  
 $I_B$  = Unbalance Current

## Modularity & Expandability

- › **Paralleling:** The available rating of the ASVG can be increased by connecting any number of units in parallel considering future load demands. A single CT set can be used for connecting up to 8 units in parallel. Additional CTs must be installed if more than 8 Units are to be used in parallel configuration.

Paralleling is possible in ASVG with different ratings as well to achieve any desired rating.

- › **Replaceability:** If any module becomes faulty during operation, it can be replaced by another module of similar rating without affecting the operation of the rest of the capacity. This reduces the downtime of AHF.

For example, 350 KVAR ASVG, which has 3 numbers of 100 KVAR ASVG & 1 Number of 50 KVAR ASVG.

## Technical Specifications

| TECHNICAL SPECIFICATIONS OF ADVANCE STATIC VAR GENERATOR |   |   |                       |
|--|---|---|-----------------------|
| Sr. No.  | INPUT   |   |                       |
| 1  | Model   | ASVG - 4W/3W  |                       |
| 2  | Input Voltage   | 415 V<br>3P4W (+10%, -25%)<br>3P3W (+15%, -25%)   |                       |
| 4  | Ratings   | 30 KVAR   | 50 KVAR      100 KVAR |
| 5  | Frequency   | 50Hz,+/-5%  |                       |
| <b>FILTER</b>  |   |   |                       |
| 6  | Harmonic Range  | 3 <sup>rd</sup> to 15 <sup>th</sup> order   |                       |
| 7  | Inverter technology (Three level/<br>two level topology, IGBT ) | Three level   |                       |
| 8  | Power Efficiency  | > 97%   |                       |
| 9  | Response time   | < 50µs  |                       |
| 10   | Correction Time   | < 20 msec   |                       |
| 11   | Function Selection  | PF Correction, Harmonic Mitigation & Unbalance correction   |                       |
| 12   | Target PF range   | Adjustable from -1 to +1  |                       |
| 13   | Current Transformer   | Sec 5 A, Class 1, 15VA rating   |                       |
| <b>PHYSICAL CHARACTERISTICS</b>                          |   |   |                       |
| 14   | Design  | Modular   |                       |
| 15   | Mounting  | Wall mount/ Rack type   |                       |
| 16   | Protection Class  | IP20  |                       |
| 17   | Cooling   | Forced air  |                       |
| <b>ENVIRONMENTAL</b>                                     |   |   |                       |
| 18   | Ambient Temperature   | -10 to 45 Deg C   |                       |
| 19   | Relative Humidity   | 95% (Non condensing)  |                       |
| 20   | Maximum operating altitude<br>without de-rating                 | 2000 m  |                       |
| 21   | Noise Level   | <65dB   |                       |
| <b>USER INTERFACE</b>                                    |   |   |                       |
| 22   | HMI   | Wall Mount - Inbuilt 4.3 Inch<br>Rack Mount - External 7 inch HMI Required  |                       |
| 23   | Hybrid controller   | Yes, Optional (with Transistor / Relay)   |                       |
| 24   | Interface (Communication)                                       | MODBUS-RTU  |                       |
| <b>PROTECTIONS AND STANDARDS</b>                         |   |   |                       |
| 25   | Protections   | Fast acting semiconductor fuses   |                       |
| 26   | Alarms  | Over Current, Over Voltage, Over Temperature, IGBT Saturation, Grid Fault, Surge, DC Bus protection, EEPROM Fault, CT Detection fault |                       |
| 27   | Safety Standard   | EN 50178:1997/ IEC 50178:1997   |                       |
| 28   | Certifications  | EN 61000-6-2 (2005)/ EN55011, GROUP 1<br>Class A IEC 61000-6-2 (1999)/ CISPR11, GROUP1, Class A                                       |                       |

## Dimensions

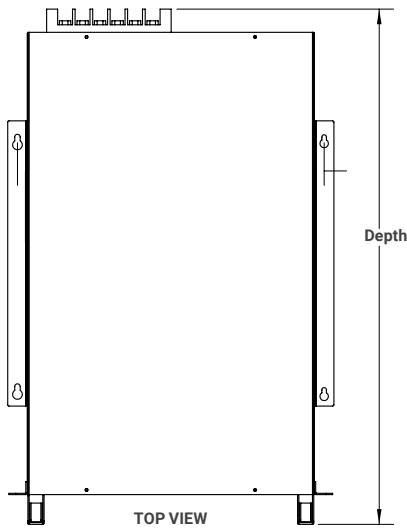
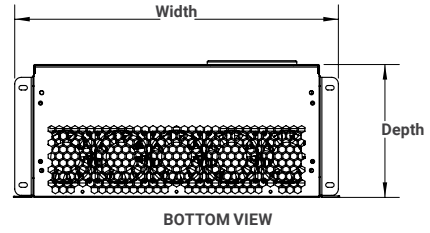
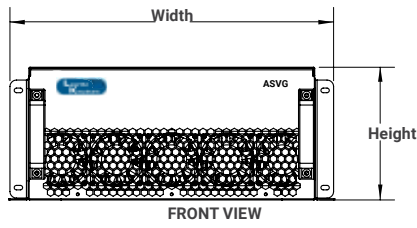

**Rack Mount Module**

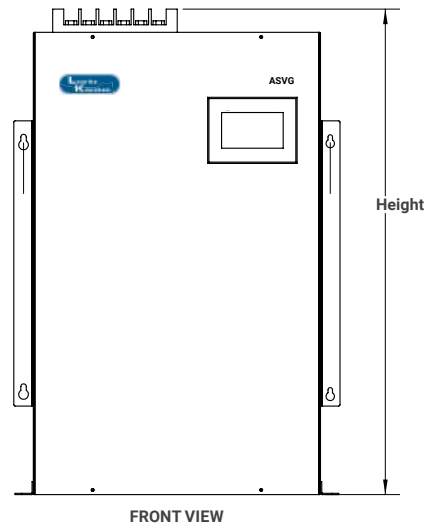

**Wall Mount Module**

| 3 Ph 3 Wire / 4 Wire, 415V Advanced Static VAR Generator |                           |  |                |       |        |
|--|---------------------------|--|----------------|-------|--------|
| CAT No.  | Model No.                 | Cable Size - Copper Single Core Flexible | Dimension (mm) |       |        |
|  |                           |  | Width          | Depth | Height |
| ASVG0030H3WD2  | ASVG - 3W- 30 KVAR, Wall  | 3 X 16 sq.mm (RYB)                       | 500            | 212   | 559    |
| ASVG0030H4WD2  | ASVG - 4W- 30 KVAR, Wall  | 4 X 16 sq.mm (RYBN)                      |                |       |        |
| ASVG0030N3RD2  | AS VG - 3W- 30 KVAR, Rack | 3 X 16 sq.mm (RYB)                       | 500            | 605   | 212    |
| ASVG0030N4RD2  | ASVG - 4W- 30 KVAR, Rack  | 4 X 16 sq.mm (RYBN)                      |                |       |        |
| ASVG0050H3WD2  | ASVG - 3W- 50 KVAR, Wall  | 3 X 35 sq.mm (RYB)                       | 500            | 200   | 666    |
| ASVG0050H4WD2  | ASVG - 4W- 50 KVAR, Wall  | 4 X 35 sq.mm (RYBN)                      |                |       |        |
| ASVG0050N3RD2  | ASVG - 3W- 50 KVAR, Rack  | 3 X 35 sq.mm (RYB)                       | 500            | 712   | 200    |
| ASVG0050N4RD2  | ASVG - 4W- 50 KVAR, Rack  | 4 X 35 sq.mm (RYBN)                      |                |       |        |
| ASVG0100H3WD2  | ASVG - 3W- 100 KVAR, Wall | 3 X 70 sq.mm (RYB)                       | 500            | 204   | 749    |
| ASVG0100H4WD2  | ASVG - 4W- 100 KVAR, Wall | 4 X 70 sq.mm (RYBN)                      |                |       |        |
| ASVG0100N3RD2  | ASVG - 3W- 100 KVAR, Rack | 3 X 70 sq.mm (RYB)                       | 500            | 795   | 204    |
| ASVG0100N4RD2  | ASVG - 4W- 100 KVAR, Rack | 4 X 70 sq.mm (RYBN)                      |                |       |        |

# Capacitor Switching in APFC Panel

The switching of capacitor banks is a special and challenging task in Automatic Power Factor Correction (APFC) panels. The selection of appropriate switching device for such application is based on two criteria:

- › Ability to carry rated capacitor current continuously
- › Ability to withstand the peak-inrush current of capacitor

It is simple to calculate the capacitor rated current and select the switching device to be able to carry rated capacitor current (2.5 to 3 times the capacitor rated current to take care of overload, harmonics, supply voltage variation and capacitor value tolerance). However, it is little difficult to select the switching device which is able to withstand the peak-inrush current. This is because the peak inrush current for capacitor switching application depends upon various factors such as:

- › The inductance of the network (including cables, switchgears and transformer)
- › The transformer power rating and percentage impedance

- › Method used for power factor correction
  - › Fixed capacitor bank
  - › Multi-stage capacitor bank with steps of equal ratings
  - › Multi-stage capacitor bank with steps of unequal ratings
- › In multi-stage capacitor bank, the numbers and rating of steps already switched on

In most of the installations, the multi-stage capacitor banks are used as steps of unequal ratings. The bigger steps of higher kVAr ratings being switched on initially and smaller steps are switched on periodically, for achieving the targeted power factor. In such cases, the value of inrush-current peak will be far higher and hence the smaller capacitors will be heavily stressed.

Capacitor switching can be done by various ways like:

## Power Contactor

- › Normal power contactors simply allow the inrush current to flow through it. Because of this, contactors and capacitors are heavily stressed. So the contactor selection should be such that it withstands the heavy inrush current. Hence, power contactors need to be heavily de-rated.
- › This inrush current also stresses the power capacitors and may result in their premature failure.
- › Power contactors should be used along with inrush current limiting resistors, for reducing the magnitude of inrush current. However, this increases the cost & size of the APFC panel along with extra power losses.

## Capacitor Duty Contactor

- › Capacitor duty contactors can be used to limit the inrush current to less than  $10 \cdot I_N$ .
- › Capacitor duty contactors have pre-contacts/auxiliary contacts with current limiting resistors (of 4 W). At the moment of switching, the pre-contacts (with resistors) close first. This reduces the inrush current to less than  $10 \cdot I_N$ . After a few milliseconds, main contacts are closed and the pre-contacts will open and go out of the circuit.
- › Capacitor duty contactors are employed where the frequency of switching is less i.e., the load fluctuation is not very fast. The capacitor requires atleast 60 seconds to discharge to a nominal value (50 V). So capacitor duty contactors cannot be used when load fluctuation is heavy.

## Thyristor Switching Module (TSM)

- › TSM is a static switching device that is used specially for switching capacitors (dynamic power factor correction), wherever the load fluctuation is heavy (like welding, steel rolling, etc.).
- › Rapid switching (5 ms to 20 ms) is possible with TSM along with Quick Discharge Resistor (QDR).
- › There is no inrush current while using TSM (zero voltage switching). So frequent switching does not affect the life of capacitors and there is no need for extra current limiting resistors.
- › TSM has thermal cutoff, which switches off the module when temperature exceeds beyond a certain limit. It automatically switches on when optimum temperature is attained.

# A Comparative Study of Switching Methods

Capacitor switching always remains as one of the challenging operations. Capacitor draws very high inrush current for a very short duration. Due to this, life of all the devices in the circuit like capacitor, contactor, short circuit protection device (SCPD) and cables are affected. They all are subjected to thermal & electrical stress, each time the capacitor is switched on & off. Various switching options are available like Power Contactors (Ac3 duty) & Capacitor Duty Contactors (AC6b duty). In spite of good options of AC6b contactors available, switching capacitor through AC3 contactor is very popular even now.

## Issues while switching with AC3 duty contactors:

Even today, majority of the users employ power contactors (Ac3 duty) to switch capacitors in APFC panels. In order to ensure the contactor withstands both the inrush current and capacitor current along with harmonics, as a rule of thumb, contactor is simply derated to 2 to 2.5 times the rated current. For example, in order to switch 100 kVAr capacitor, they select 225 A (MNX 225) AC3 rated contactor.

## Issues while switching with AC3 duty contactors with series detuned reactors:

Some users believe that when detuned reactors (7% or 14%) are used along with capacitors, the inrush current would reduce. It is true to some extent, but the time duration of high frequency oscillation is actually longer than switching pure capacitors.

Use of AC3 duty contactors, derated as per thumb rule, is generally not recommended, as they do not limit the inrush current. This increases the probability of failure of capacitors due to damage of metal spray layer (as shown in fig) because of High inrush current magnitude & frequency. If MCCBs are used as SCPD, their contacts would bounce due to high inrush current and may get damaged (pitting & carbon formation). The high inrush current may result in nuisance operation of fuses as well. Such issues in SCPDs are very well documented in various sites.



This also increases the peak transient voltages and the same is applied across the capacitors. This causes high voltage stress to the capacitors and the dielectric may fail prematurely.

### Switching with Capacitor Duty Contactors (Ac6b):

The next best option is use of capacitor duty contactors with pre-closing resistors (as shown in fig). Though they do not have a point-on wave control, they are very effective in controlling inrush currents due to the presence of pre-closing resistors. The resistance value is generally in the range of 2 to 6 Ohms, with 4 ohms being typical. Considering a system voltage of 440 V and a 25 kVAR capacitor, the rated current is 32 A. Even when switched at the peak of the voltage and assuming that capacitor behaves as a complete short circuit, the current would be limited to a peak of 155 ( $440 \times 1.414 / 4$ ), which is just 3.5 times the rated peak current ( $32 \times 1.414$ ). In practical cases the actual inrush current could be much lower considering other circuit impedances and the probability that the switching could happen at any point on wave, including voltage zero.

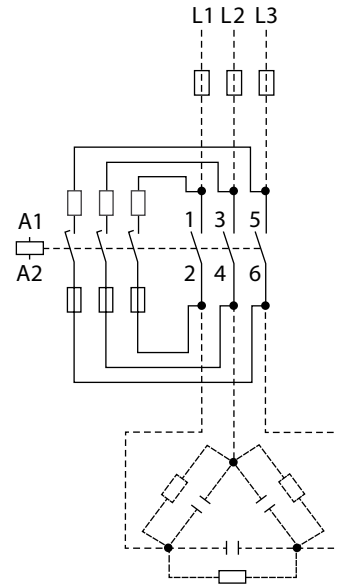

AC6B duty contactors also help damp the switching transient oscillation due to the insertion of a ohmic resistance in the circuit during switching instant. The presence of this resistance effectively damps the transient and reduces the duration of oscillation.

The switching performances of AC3 and AC6b duty contactors, with and without 7% series reactors has been compared through simulation.

### Simulation

- › 25 kVAR, 440 V capacitor with rated current of 32 A is considered
- › Single-phase equivalent circuit is considered with voltage of 254 V rms (L -N), V<sub>peak</sub> of 360 V (equivalent to 440 V L -L, three phase).
- › 5 ms time lag between resistor contacts and main contacts in case of AC6B contactors is considered
- › Lead inductance per step = 1.7uH, 7% reactor per step = 1.7 mH
- › Observe the duration of transient, which is very short in some cases
- › In some cases the voltage / current is amplified due to resonance at switching frequency
- › In practical cases, the circuit would be more complex with additional lead inductances, stray capacitance and distributed ohmic resistances and generally will have a higher damping
- › Practical values could be slightly different from due to simplified circuit used for simulation
- › 10x capacitors switched at peak voltage with AC3 & AC6b contactors and with & without 7% detuned reactors.
- › In the below results,
  - › First waveform represents supply voltage
  - › Second one represents Capacitor current and
  - › Third one is the Voltage across capacitor terminals

### 1. 10X parallel capacitor bank with AC3 and no series reactor, switching at peak voltage

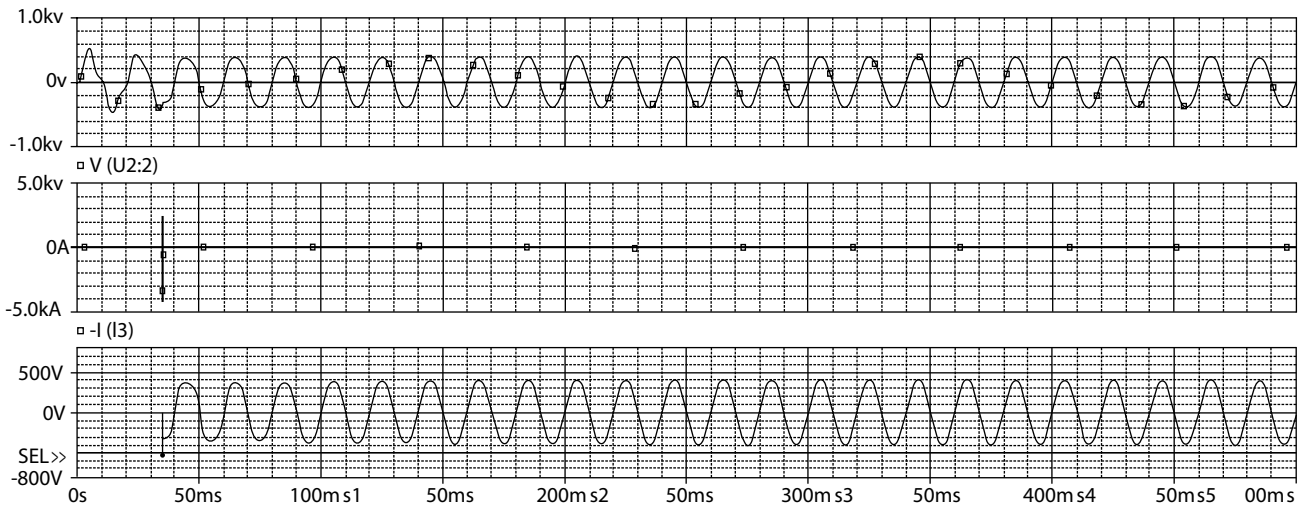

$I_{peak} = 4000 \text{ A}$   
 $V_{peak} \text{ across the capacitor} = 415 \text{ V}$

### 2. 10X parallel capacitor bank with AC3 and with 7% series reactor, switching at peak voltage

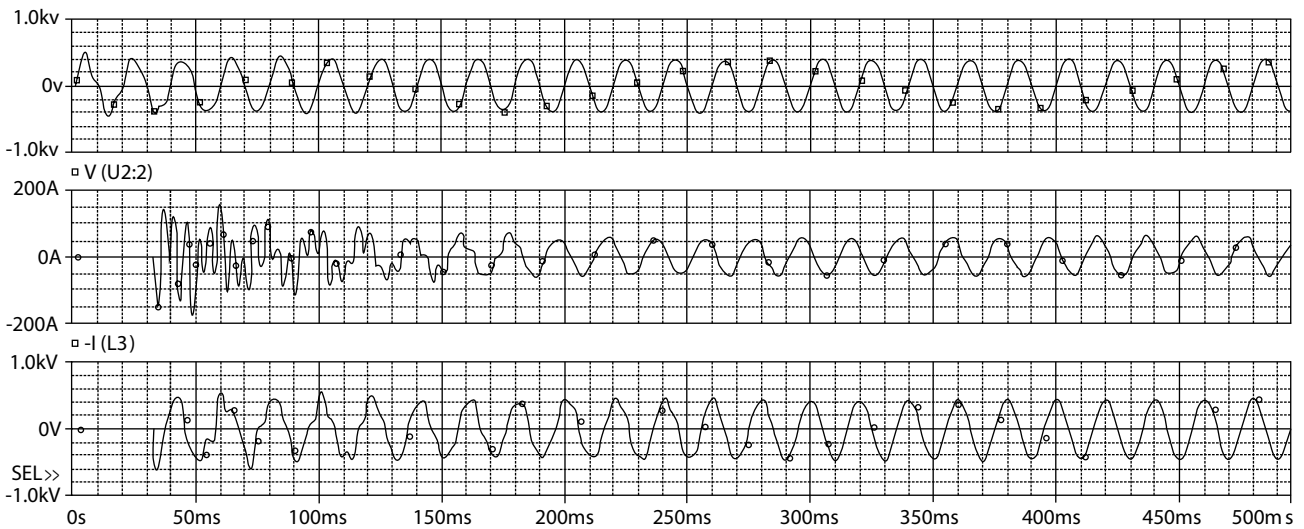

$I_{peak} = 200 \text{ A}$   
 $V_{peak} \text{ across the capacitor} = 600 \text{ V}$

### 3. 10X parallel capacitor bank with AC6B and no series reactor, switching at peak voltage

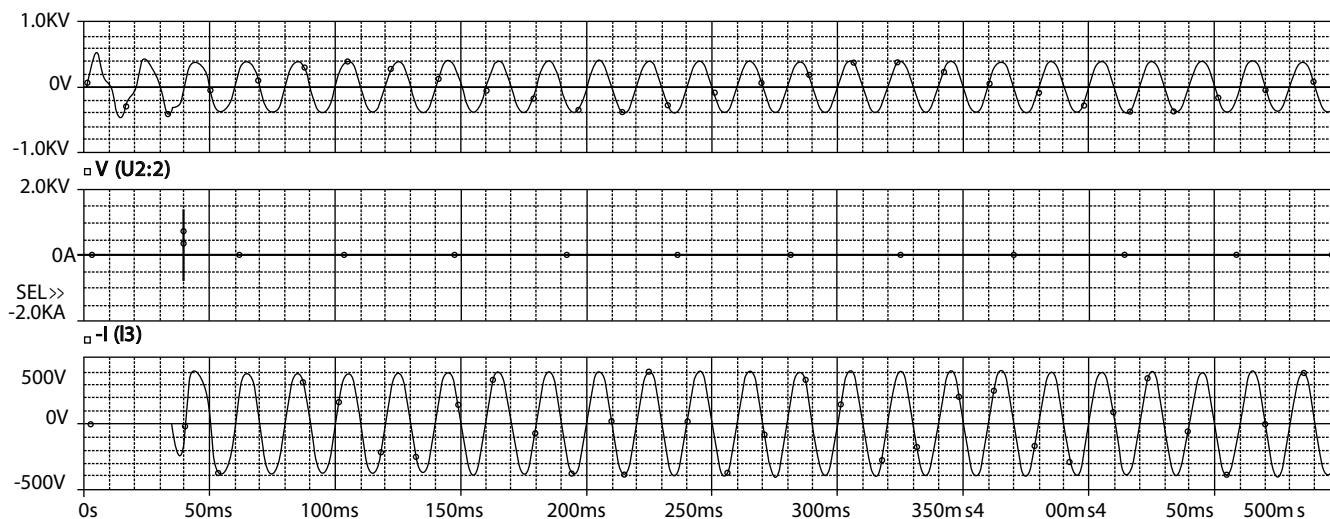

$I_{peak} = 1400 \text{ A}$   
 $V_{peak}$  across the capacitor = 400 V

### 4. 10X parallel capacitor bank with AC6B and with 7% series reactor, switching at peak voltage

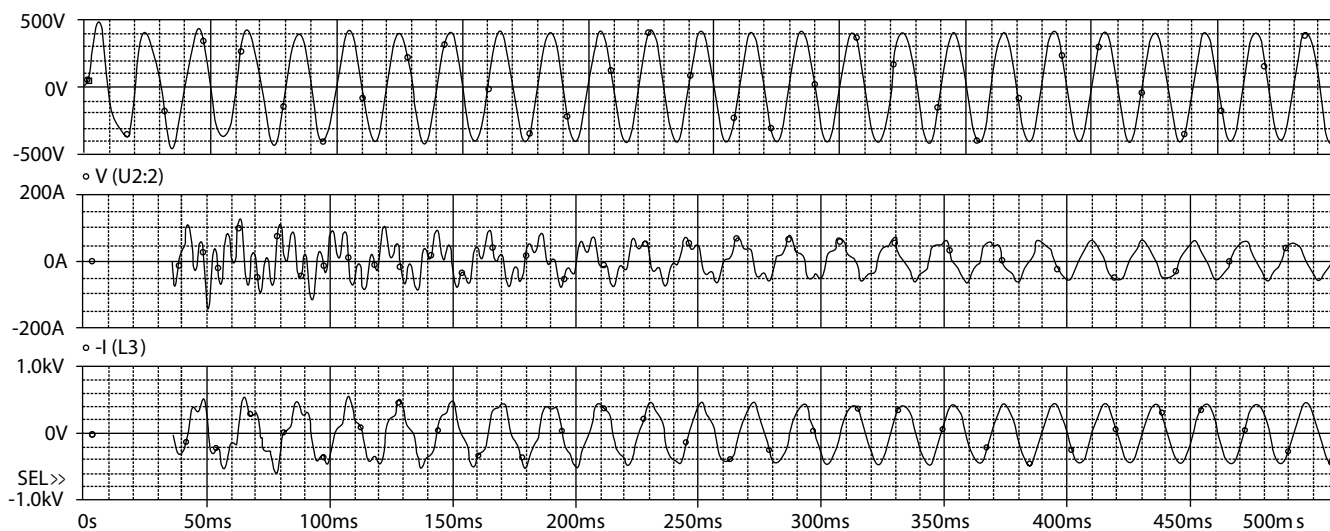

$I_{peak} = 140 \text{ A}$   
 $V_{peak}$  across the capacitor = 565 V

## Summary

Below table is the summary of above simulation, where the peak inrush current values and peak transient voltages across capacitors are shown:

|                    |                 | AC3 contactor          | AC6b contactor         |
|--------------------|-----------------|------------------------|------------------------|
| 10x parallel banks | With 7% reactor | $I_p = 200 \text{ A}$  | $I_p = 140 \text{ A}$  |
|                    |                 | $V_p = 600 \text{ V}$  | $V_p = 565 \text{ V}$  |
|                    | w/o reactor     | $I_p = 4000 \text{ A}$ | $I_p = 1400 \text{ A}$ |
|                    |                 | $V_p = 415 \text{ V}$  | $V_p = 400 \text{ V}$  |

What is important is not just the peak value, but duration of peak and duration of oscillations. Below table represents the duration of some:

| Parameters                        | AC3 duty     | AC6b duty    | AC3 duty + reactor | AC6b duty + reactor |
|-----------------------------------|--------------|--------------|--------------------|---------------------|
| Peak current                      | 450 A        | 190 A        | 220 A              | 115 A               |
| Peak voltage                      | 700 V        | 480 V        | 750 V              | 520 V               |
| Duration of oscillation (current) | Up to 150 ms | Up to 130 ms | Up to 500 ms       | Up to 400 ms        |
| Duration of oscillation (voltage) | Up to 110 ms | Up to 90 ms  | Up to 400 ms       | Up to 200 ms        |

From the above tables it can be inferred that:

- › Traditional method of using power contactors results in very high peak inrush current & voltage.
- › Another traditional method of using power contactors along with series reactors (0.2% or 7%), though reduces the peak current value, still there is a significant increase in peak transient voltage and duration of oscillations. This is more dangerous to capacitors & switchgear.
- › If reactors are used along with capacitors, switching with capacitor duty contactor will reduce both current & voltage peak values due to the addition of ohmic resistance (R) in series. This also reduces the duration of oscillation.
- › Higher peak currents / voltages observed in some cases is not due to switching transients, but due to possible resonance at switching frequency as can be observed from the wave shape (oscillations with DC offset and first peak lower than subsequent peaks)

As the results indicate, reducing inrush current by introducing resistance in the capacitor circuit is the best method, whether with or without reactors. Usage of derated Power Contactors (AC3) will just withstand the inrush current. From cost point of view, derated AC3 contactors will be more expensive than AC6b equivalent. Addition of inductance with AC3 contactor results in increased oscillations and can cause failure of capacitor & contactor itself. Trouble free operation of all the components in APFC panels are very important because the user may end up paying huge penalty, in case power factor is not maintained above the prescribed limits. Proper switching with capacitor duty contactor is one of ways of ensuring that.

# Capacitor Duty Contactor - Type MOC

MO C Capacitor Duty Contactors are specially designed for capacitor switching applications. As capacitor switching is associated with high inrush current, the contactors are provided with damping resistors which limit the value of inrush current to a safe value. The contactors are used in APFC panels for switching power capacitors depending upon the amount of reactive power compensation required.

## Benefits of using Capacitor Duty Contactors

Since switching of capacitor banks involves high transient inrush currents, the size of the contactor required to switch these high currents becomes higher. Hence, current limiting inductors are used in series to attenuate this inrush current. This increases the system cost and panel space.

A typical case below illustrates the magnitude of transient inrush current for switching of a capacitor bank. For a 12.5 kVAr capacitor bank:

Rated current of 12.5 kVAr 415 V Capacitor = 18A  
Peak Inrush current without Damping Resistors = 1200A

Capacitor Duty Contactors are designed to limit this high transient inrush current by introducing damping resistors with early make auxiliary contacts. The current limiting due to damping resistors protects the APFC system from harmful effects of the capacitor charging inrush current.

Peak Inrush current with Damping Resistors = 260A  
It is observed that peak inrush current with damping resistors is one fifth of that without damping resistors. As the contactor is now required to switch the rated capacitor current, the size of the contactor required is smaller. Thus the system cost and panel space are significantly lower when Capacitor Duty Contactors are used.



## MO C Capacitor Duty Contactors

MO C Capacitor Duty Contactors are designed for switching 3 phase, single or multi-step capacitor bank. In conventional capacitor switching contactors, early make auxiliary contacts used for insertion of damping resistors used to remain in the circuit continuously. During current breaking these auxiliary contacts would also carry and break the currents due to higher arc resistance in the main pole during arcing. This current breaking by auxiliary contacts at higher transient recovery voltage causes unreliable product performance and premature product failures.

MO C range of capacitor switching contactors have patented mechanism which disconnects the early make auxiliary contacts after the main contacts are closed. This completely eliminates the possibility of auxiliary contacts carrying and breaking the currents during breaking operation. This enhances the product switching performance and improves the product life.

## Features and Benefits of MO C Capacitor Duty Contactors

| Feature  | Customer Benefits                    |
|--|--------------------------------------|
| De-latching auxiliary contacts                                     | Improved switching performance       |
|  | Reduced losses in auxiliary contacts |
| Dual contact gap for auxiliary contacts                            | Higher electrical life               |
| Encapsulated resistor assembly                                     | Enhanced product safety              |
|  | No flash over between phases         |
| Separate termination of damping resistors                          | Ease of wiring                       |
|  | Enhanced operational reliability     |
| Wide and chatter-free operating band and in-built surge suppressor | Improved switching performance       |
|  | Higher electrical life               |
|  | Higher product reliability           |

## Ordering Information Contactors

| Product Designation | kVAr Rating @ 415V 50Hz | In Built Aux contacts | Cat. No.* |
|---------------------|-------------------------|-----------------------|-----------|
| MO C3               | 3                       | 1 NO                  | CS96146   |
| MO C5               | 5                       | 1 NO                  | CS96127   |
| MO C8.5             | 8.5                     | 1 NO                  | CS96320   |
| MO C10              | 10                      | 1 NO                  | CS96156   |
| MO C12.5            | 12.5                    | 1 NO                  | CS96321   |
| MO C15              | 15                      | 1 NO                  | CS90019   |
| MO C20              | 20                      | 1 NO                  | CS90021   |
| MO C25              | 25                      | 1 NO                  | CS96322   |
| MO C30              | 30                      | 1 NO                  | CS96148   |
| MO C40              | 40                      | 1 NO                  | CS96147   |
| MO C50              | 50                      | 1 NO                  | CS96324   |
| MO C60              | 60                      | 1 NO                  | CS96149   |
| MO C75              | 75                      | 1 NO                  | CS96150   |
| MO C85              | 85                      | 1 NO                  | CS96157   |
| MO C100             | 100                     | 1 NO                  | CS96158   |

\*Add four digit suffix as per coil voltage

## Accessories & Spares Add on Blocks

| Mounting Position | Contacts    | Cat. No.    |
|-------------------|-------------|-------------|
| First Left        | 1 NO + 1 NC | CS945800000 |
| First Right       | 1 NO + 1 NC | CS945810000 |
| Second Left       | 1 NO + 1 NC | CS945820000 |
| Second Right      | 1 NO + 1 NC | CS945830000 |

## Spare Coils

| For Contactor | Cat. No. |
|---------------|----------|
| MO C3 - C30   | CS96317  |
| MO C40 - 60   | CS96318  |
| MO C70 - 100  | CS96319  |

\* Add four digit suffix as per coil voltage

## Accessories & Spares Add on Blocks

| For Contactor | Cat. No.    |
|---------------|-------------|
| Mo C3 - 30    | CS942740000 |
| MO C40 - 60   | CS940930000 |
| MO C75 - 100  | CS940940000 |



Note: 1) Spreader Link Kit consists of six terminals  
2) Use above Spreader Link when using MO C 25  
16 sq. mm cable

## Ordering Suffix for Coil Voltages

| Std Coil Voltage        | 110  | 220  | 240  | 415  |
|-------------------------|------|------|------|------|
| Ordering Suffix - 50 Hz | A000 | K000 | B000 | D000 |
| Ordering Suffix - 60 Hz | Y000 | V000 | -    | S000 |

## Technical Chart

- › Available for capacitor range from 3 - 100 kVAr
- › Modular design saving precious panel space
- › De-Latching auxiliary contacts
- › Separate termination of damping resistors
- › Encapsulated resistor assembly ensuring safety
- › In-built surge suppressor with the coil
- › Lugless termination



| Type Designation                          |                             |                 | MO C3           | MO C5    | MO C8.5           | MO C10            | MO C12.5          |                   |
|---|-----------------------------|-----------------|-----------------|----------|-------------------|-------------------|-------------------|-------------------|
| kVAr Rating (at System voltage 440 V)#    |                             | kVAr            | 3               | 5        | 9                 | 10                | 13                |                   |
| Catalogue No.                             | Built in Aux Contacts       | 1 NO            | Cs96146         | Cs96127  | Cs96320           | Cs96156           | Cs96321           |                   |
| Conformance to Standards                  |                             |                 |                 |          |                   |                   |                   |                   |
| Rated Operational Current at 440 V, 50 Hz |                             | Ie              | A               | 3.9      | 6.6               | 11.2              | 13.1              | 16.4              |
| Short Circuit Protection                  |                             |                 |                 |          |                   |                   |                   |                   |
| Max. Operational Voltage                  |                             | Ue              | V               | 690      | 690               | 690               | 690               | 690               |
| Rated insulation Voltage                  |                             | Ui              | V               | 1000     | 1000              | 1000              | 1000              | 1000              |
| Rated Impulse Withstand Voltage           |                             | Uimp            | Kv              | 8        | 8                 | 8                 | 8                 | 8                 |
| Degree of Protection                      |                             |                 |                 |          |                   |                   |                   |                   |
| Main Terminal Capacity                    | Cable with Ferrule type lug |                 |                 |          |                   |                   |                   |                   |
|   | Cable with Pin type lug     |                 |                 |          |                   |                   |                   |                   |
|   | Cable with Fork type lug    |                 |                 |          |                   |                   |                   |                   |
|   | Cable with Ring type lug    |                 |                 |          |                   |                   |                   |                   |
|   | Solid Conductor             |                 | mm <sup>2</sup> | 2 x 10   | 2 x 10            | 2 x 10            | 2 x 10            | 2 x 10            |
|   | Stranded Conductor          |                 | mm <sup>2</sup> | 2 x 10   | 2 x 10            | 2 x 10            | 2 x 10            | 2 x 10            |
|   | Finely Stranded Conductor   |                 | mm <sup>2</sup> | 2 x 6    | 2 x 6             | 2 x 6             | 2 x 6             | 2 x 6             |
| Coil Operating Band                       | Pick-up                     | % Uc            | V               | 65 - 110 | 65 - 110          | 65 - 110          | 65 - 110          | 65 - 110          |
|   | Drop-off                    | % Uc            | V               | 35 - 65  | 35 - 65           | 35 - 65           | 35 - 65           | 35 - 65           |
| Coil Consumption                          | Pick-up                     |                 | VA              | 77       | 77                | 77                | 77                | 77                |
|   | Hold-on                     |                 | VA              | 9        | 9                 | 9                 | 9                 | 9                 |
|   |                             |                 | W               | 3        | 3                 | 3                 | 3                 | 3                 |
| Life (Operating Cycles)                   |                             | Mechanical      | Million         | 10       | 10                | 10                | 10                | 10                |
|   |                             | Electrical      | Million         | 0.2      | 0.2               | 0.2               | 0.2               | 0.2               |
| Max. Operating Frequency                  |                             | Operations / Hr |                 | 240      | 240               | 240               | 240               | 240               |
| Operating Sequence                        | Making                      |                 |                 |          |                   |                   |                   |                   |
|   | Breaking                    |                 |                 |          |                   |                   |                   |                   |
| Overall Dimensions                        | Height                      | H               | mm              | 87       | 87                | 87                | 87                | 87                |
|   | Width                       | W               | mm              | 45       | 45                | 45                | 45                | 45                |
|   | Depth                       | D               | mm              | 133.5    | 133.5             | 133.5             | 133.5             | 133.5             |
|   | Mounting Dimensions         |                 |                 | mm       | 35 x 60 - 65 - 70 | 35 x 60 - 65 - 70 | 35 x 60 - 65 - 70 | 35 x 60 - 65 - 70 |

Note: Contact replacement is not permitted in MO C contactors

\* Accessories and Spares same as that of MO contactor.

\*\* Dimension is with the spreader link

# kVAr ratings should be selected as per the net kVAr of the capacitor reactor combination irrespective of capacitor voltage (440V/480V/525V)

# While selection it should be ensured that current rating of capacitor is less than the current through the contactor

\$ Use spreader while using 16 sq.mm cable

\$\$ Terminal capacity mentioned is with spreader



| MO C15  | MO C20      | MO C25              | MO C30               | MO C40         | MO C50         | MO C60               | MO C75         | MO C85         | MO C100              |
|---|-------------|---------------------|----------------------|----------------|----------------|----------------------|----------------|----------------|----------------------|
| 15  | 20          | 25                  | 30                   | 40             | 50             | 60                   | 75             | 85             | 100                  |
| Cs90019                                       | Cs90021     | Cs96322             | Cs96148              | Cs96147        | Cs96324        | Cs96149              | Cs96150        | Cs96160        | Cs96158              |
| IS/IEC 60947-4-1, IEC 60947-4-1, EN 60947-4-1 |             |                     |                      |                |                |                      |                |                |                      |
| 19.7  | 26.2        | 32.8                | 39.4                 | 52.5           | 65.6           | 78.7                 | 98.4           | 111.5          | 131                  |
| gG type fuses rated at 1.5-2 le               |             |                     |                      |                |                |                      |                |                |                      |
| 690   | 690         | 690                 | 690                  | 690            | 690            | 690                  | 690            | 690            | 690                  |
| 1000  | 1000        | 1000                | 1000                 | 1000           | 1000           | 1000                 | 1000           | 1000           | 1000                 |
| 8   | 8           | 8                   | 8                    | 8              | 8              | 8                    | 8              | 8              | 8                    |
|   | lp20        |                     |                      |                |                |                      |                |                |                      |
|   | 1 x (4-10)  |                     |                      |                |                |                      |                |                | -                    |
|   | 1 x (4-10)  |                     |                      |                |                |                      |                |                | -                    |
|   | 1 x (4-10)  |                     |                      |                |                |                      |                |                | -                    |
|   | -           |                     |                      |                |                |                      |                |                | 1 x (10 - 15)        |
| 2 x 10  | 2 x 10      | 2 x 10 <sup>§</sup> | 2 x 16 <sup>§§</sup> | -              | -              | -                    | -              | -              | -                    |
| 2 x 10  | 2 x 10      | 2 x 10 <sup>§</sup> | 2 x 16 <sup>§§</sup> | 2 x 35         | 2 x 35         | 2 x 35 <sup>§§</sup> | 2 x 70         | 2 x 70         | 2 x 95 <sup>§§</sup> |
| 2 x 6   | 2 x 6       | 2 x 6 <sup>§</sup>  | 2 x 6 <sup>§§</sup>  | 2 x 35         | 2 x 25         | 2 x 35 <sup>§§</sup> | 2 x 50         | 2 x 50         | 2 x 95 <sup>§§</sup> |
| 65 - 110                                      | 65 - 110    | 65 - 110            | 65 - 110             | 75 - 110       | 75 - 110       | 75 - 110             | 75 - 110       | 75 - 110       | 75 - 110             |
| 35 - 65                                       | 35 - 65     | 35 - 65             | 35 - 65              | 35 - 65        | 35 - 65        | 35 - 65              | 35 - 65        | 35 - 65        | 35 - 65              |
| 77  | 77          | 77                  | 77                   | 77             | 77             | 77                   | 77             | 77             | 77                   |
| 9   | 9           | 9                   | 9                    | 9              | 9              | 9                    | 9              | 9              | 9                    |
| 3   | 3           | 3                   | 3                    | 3              | 3              | 3                    | 3              | 3              | 3                    |
| 10  | 10          | 10                  | 10                   | 10             | 10             | 10                   | 10             | 10             | 10                   |
| 0.2   | 0.2         | 0.2                 | 0.2                  | 0.2            | 0.2            | 0.2                  | 0.2            | 0.2            | 0.2                  |
| 240   | 240         | 240                 | 240                  | 240            | 240            | 240                  | 240            | 240            | 240                  |
| Early Make / Main                             |             |                     |                      |                |                |                      |                |                |                      |
| Main Contacts Break                           |             |                     |                      |                |                |                      |                |                |                      |
| 87  | 87          | 87                  | 115**                | 123.5          | 123.5          | 174**                | 135            | 135            | 195**                |
| 45  | 45          | 45                  | 56**                 | 55             | 55             | 73**                 | 70             | 70             | 95**                 |
| 133.5   | 133.5       | 133.5               | 133.5**              | 163            | 163            | 163**                | 175            | 175            | 175**                |
| 35x60-65-70                                   | 35x60-65-70 | 35x60-65-70         | 35x60-65-70          | 45 x 100 - 105 | 45 x 100 - 105 | 45 x 100 - 105       | 60 x 115 - 120 | 60 x 115 - 120 | 60 x 115 - 120       |

# Dimension details MOC

|      |   |   |    |    |      |    |    |    |    |    |    |    |    |
|------|---|---|----|----|------|----|----|----|----|----|----|----|----|
| kVAr | 3 | 5 | 85 | 10 | 12.5 | 15 | 20 | 25 | 40 | 50 | 60 | 75 | 85 |
|------|---|---|----|----|------|----|----|----|----|----|----|----|----|

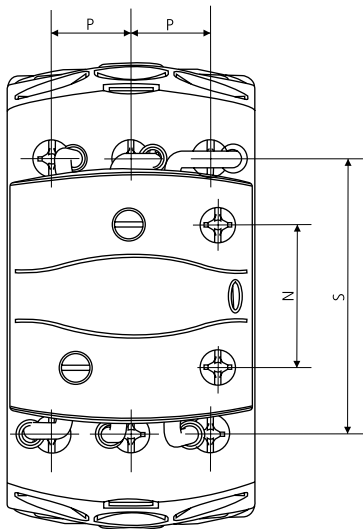
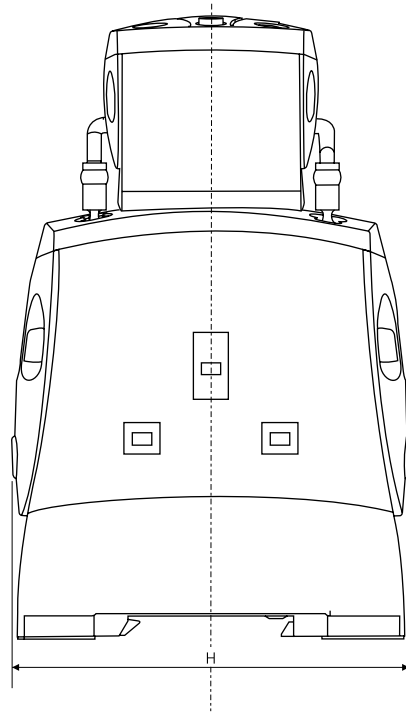
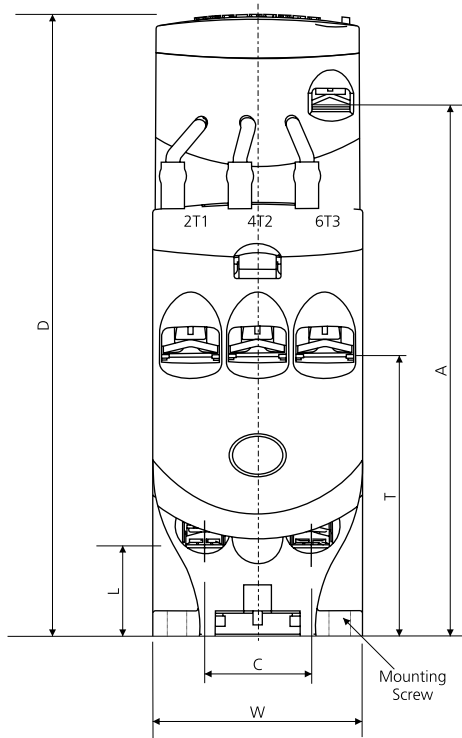

| Label | MOC    |         |         |
|-------|--------|---------|---------|
|       | 3 - 25 | 40 - 50 | 75 - 85 |
| W     | 45     | 55      | 70      |
| D     | 133.5  | 163     | 175     |
| H     | 87     | 123.5   | 135     |
| N     | 26     | 26      | 26      |
| T     | 60     | 68      | 68      |
| C     | 22.8   | 27      | 35      |
| L     | 19.6   | 29.5    | 30      |
| S     | 50     | 82      | 93      |
| P     | 14.4   | 18      | 23      |
| A     | 113    | 142     | 154     |

All dimensions in mm.

## MO C Frame 1 (with spreader links) / MO C 30

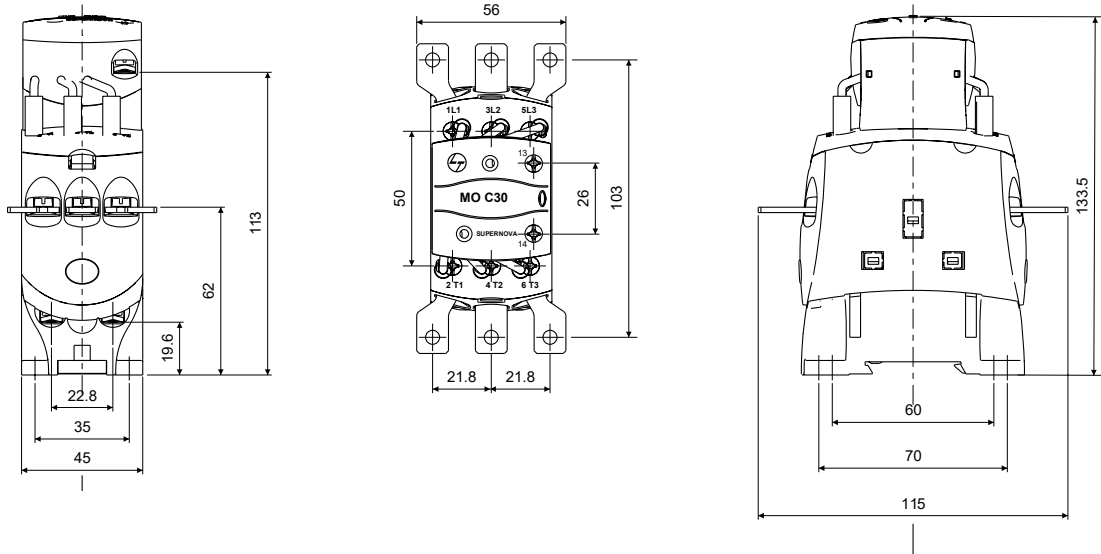

## MO C Frame 2 (with spreader links) / MO C 60

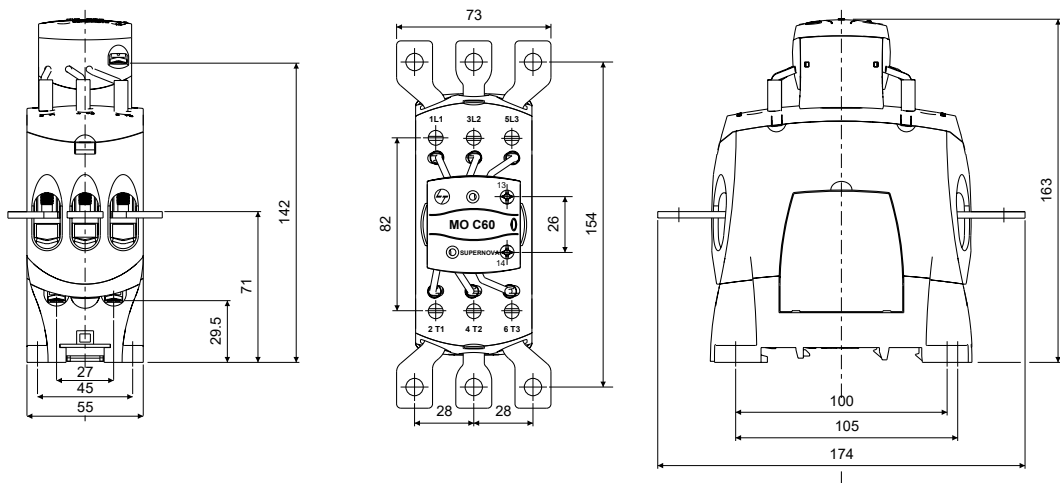

## MO C Frame 3 (with spreader links) / MO C 100

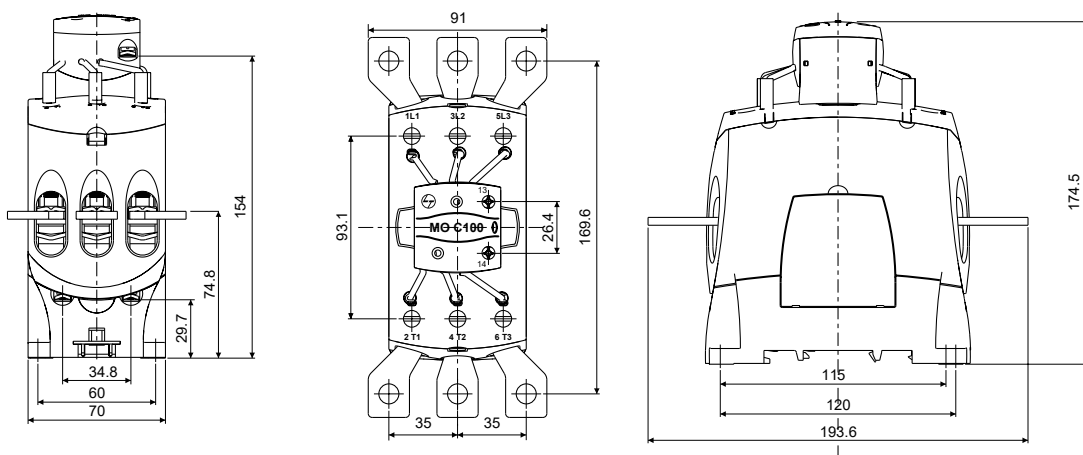

# Dynamic Power Factor Correction

Conventionally, power factor correction systems consist of power factor correction capacitors switched using capacitor duty contactors. The re-switching time is the sum of capacitor discharge time (within 75 seconds as per IEC 60831) and response time of contactor. Such arrangement is suitable for applications where few switching operations take place per day.

## Need for Dynamic Power Factor Correction

Faster response is needed when the demand for reactive power is rapidly fluctuating either due to rapidly changing load conditions or process requirements. For certain loads, like,

- › Welding equipment
- › Injection moulding equipment
- › Industrial presses
- › Loads such as, lifting cranes, elevators, lifts etc.

the demand for reactive power comes frequently and for short duration of time.

## Why Not Contactors?

Contactors are electro-mechanical devices which switch capacitors after a lag. Also, due to discharge time of capacitors, the re-switching time of contactors becomes longer than 60 seconds. This makes contactor a slow device.

Many applications increasingly require real-time reactive compensation. With this, the demand for dynamic power factor correction arises and faster switching of capacitors becomes inevitable.

This section discusses the need for thyristor switching module and the care to be taken while designing systems with thyristor switching modules.

Large reactive power demand for very short durations has severe ill-effects, such as:

- › Rapid fluctuations in voltage which may lead to system instability
- › High voltage transients may result in insulation breakdown or damage to other loads
- › Malfunctioning of sensitive electrical and electronic equipment such as relays, PLCs
- › Oversizing of electrical installation is needed since kVA capacity needs to be provided for maximum power demand

In-rush current in capacitor switching are reduced to 10 times the rated current if capacitor duty contactors are used. However, a certain pulse element is inevitable as can be seen in Figure 1.

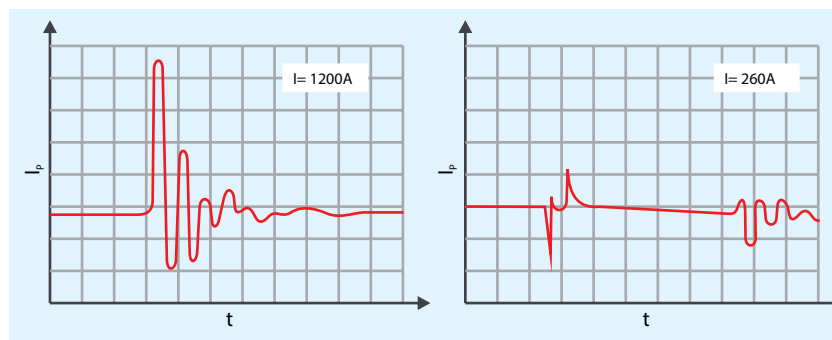

Figure 1 : Transient during capacitor switching by a) Normal contactor b) Capacitor-duty contactor

Inrush current occurrences cause high electromechanical forces within the capacitor. The dielectric inside the capacitor is highly stressed due to this high current. This could lead to reduction in the life of capacitors.

In order to obviate the above shortfalls, the thyristor switching modules are used.

## Principle of Operation of TSM

A thyristor switching module (TSM) is a fast, electronically controlled thyristor switch for switching capacitor loads within

a few milliseconds as often and as long as required.

First of all, being a thyristor-based switch, the thyristor switches the capacitor without delay. A thyristor switching module works on the principle of zero-voltage switching, i.e., the capacitor is

switched ON only when the voltage waveform is at its zero crossing. The current through a capacitor is given by:

$$I_c = C \frac{dV_c}{dt}$$

Where,  $I_c$  is capacitor current,  $C$  is capacitance and  $V_c$  is voltage across capacitor. This current is directly proportional to the rate of change of voltage across the capacitor. Thus, when capacitors are switched ON at zero crossing of supply

voltage, the voltage applied to the capacitor is almost zero and grows steadily following the sine wave. Thus, the inrush current becomes equal to the rated current.

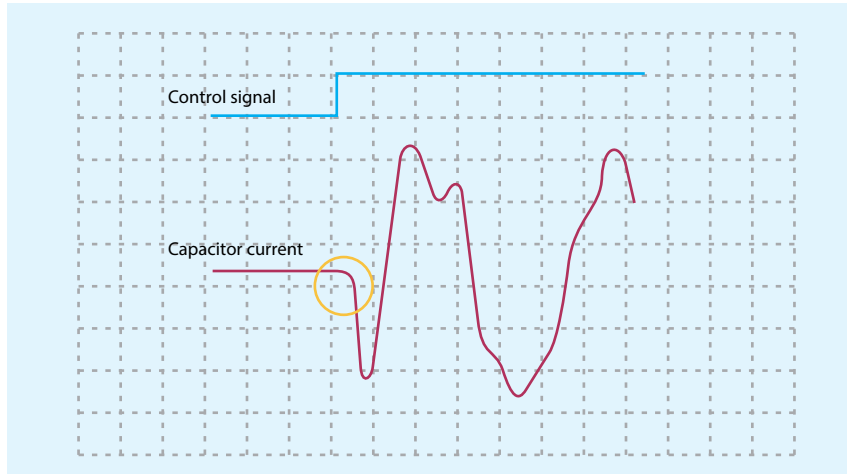

Figure 2 : Zero in-rush current during capacitor switching by TSM

## Importance of QDR

Another point to be noted here is that the capacitors used with TSM should be fitted with quick discharge resistors (QDR). If the capacitors are used with the usual discharge resistors, then, the capacitor may not get fully discharged at the time of re-switching. In such a situation, there will still be a significant voltage across the capacitor resulting in high inrush current. Quick discharge resistors ensure that the capacitor

is completely discharged before its re-switching. The typical discharge time of normal resistors is to reach less than 50 V within 60 seconds. However, for QDR, the discharge time is reduced significantly so that there is a higher probability of switching at zero crossover, making the capacitors suitable to be used with thyristor switching modules.

## PIV Rating of TSM

The typical arrangement of thyristor switches in a thyristor switching module is given in figure 3. Two terminals of a delta connected-capacitor are connected to the line via TSM while the third is connected directly to the line (all three phases have high speed fuses for branch protection). This configuration obviates the need to use three switch-pairs while ensuring that the three-phase capacitor is connected only when both switch pairs are ON or the module is ON. Each switches pair is a combination of two thyristors connected in anti-parallel for operation with ac voltage.

Peak Inverse Voltage (PIV) rating of a thyristor switch is the maximum peak voltage that the thyristor can withstand in the reverse biased condition. It is the maximum voltage that it must block when it is in OFF condition. A module with thyristors of lower PIV, say 1600 V, is likely to fail in presence high voltage surges. Hence, higher values of PIV are desirable. Typically, in capacitor switching applications, the PIV ratings are up to 2200 V.

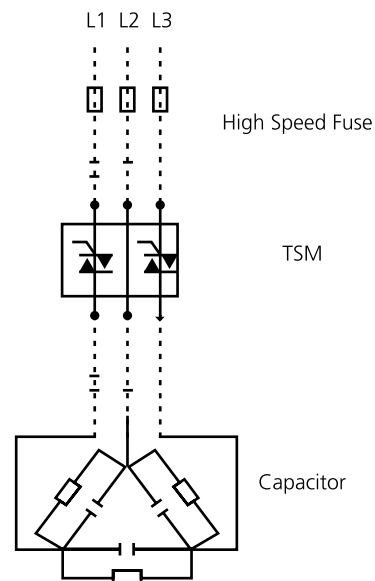

Figure 3 Arrangement of thyristor in a TSM

## Advantages of TSM

- › Faster switching of capacitors with response time from 5-40 ms can be achieved.
- › No delay due to capacitor discharge
- › No inrush current ensures that there are no resulting voltage fluctuations or transients. Thus, we get transient-free smooth switching and stable voltage and increased life of capacitors
- › No arcing owing to a static switch
- › Thyristor switches allow any number of switching operations as they are not subjected to any mechanical wear. Thus, a longer service life as compared to contactors
- › With dynamic compensation, reactive power is more efficiently compensated resulting in further lowering of energy costs
- › With reduced peak of inrush current, cables and equipment used can be of smaller short circuit rating reducing capital expenditure

## High Speed Fuse for Branch Protection

For short circuit protection of a thyristor switching module, a faster protection device is needed so that it will act before the thyristor switch in case of a short circuit. Normally, an HRC fuse has a time characteristics based on the I<sup>2</sup>t characteristics of cables as per IEC 60269-2. In case of a short circuit, the

thyristor will blow before the fuse. However, a semiconductor back-up (or a high speed) fuse has a time characteristics based on I<sup>2</sup>t characteristics of a thyristor. Hence, semiconductor fuse or high speed fuse can protect the thyristor module.

## Forced cooling for TSM

Being electronic switches, the heat generated due to losses needs to be dissipated quickly. The thyristor switching modules are generally designed with fins for better heat dissipation. They should be mounted in a position so that maximum air flow is possible. Additionally, it is always recommended to use an adequately-sized fan in the compartment where TSMs are mounted in an APFC panel.

Some thyristor switching modules come with in-built fans for cooling. Practically, it is difficult to spot a fan failure in such a case and an undetected fan failure may lead to failure of TSM. The TSM module becomes unnecessarily bulky in such cases. Hence, it is best to use fan-less modules with an adequately-sized fan on panel ceiling.

## How to Connect

A TSM is connected to the line via a semiconductor fuse and its output is given to the three-phase capacitor or a detuned filter (in case harmonics are present). Triggering of a TSM can be done by means of dynamic power factor controllers. Triggering can be done by a controller which has a transistor output. Typically, a TSM has a 24 V or/and a 12 V input and the respective currents required for triggering are approximately 15 mA and 20 mA respectively. Sometimes, more than one TSM is required to be connected to the same controller output for making a larger step, say, 100 kVAR. In such a case, more than one TSM can be connected to one output of the controller. The maximum number of TSMs that can be connected to a controller is restricted by the dc supply available and the maximum current limit of a stage output of the controller output.

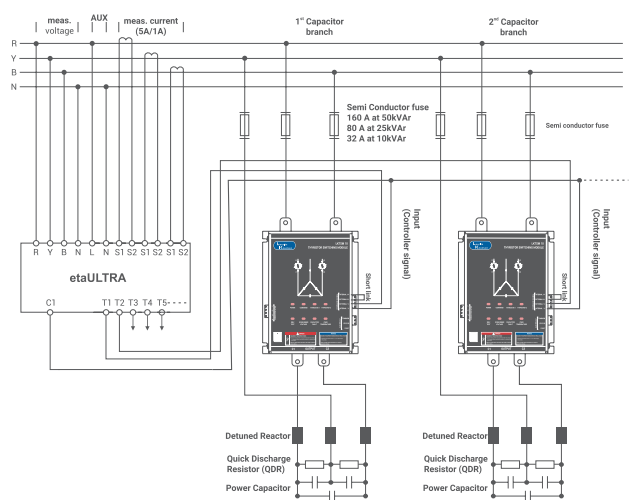

WIRING DIAGRAM FOR MULTI TSM WITH INTERNAL POWER SUPPLY

Figure 4 Connection Diagram of TSM

## Combination of Contactor - based & Thyristor-based Panels

Thyristor switching modules being expensive is often a concern for industry. An economical solution without compromising the performance of power factor correction panel can still be devised in many applications. Typically, an industry consists of

a variety of loads – some fixed loads that are always running, some varying motor loads that run for some part of the day and some highly fluctuating loads.

The following solution is suggested:

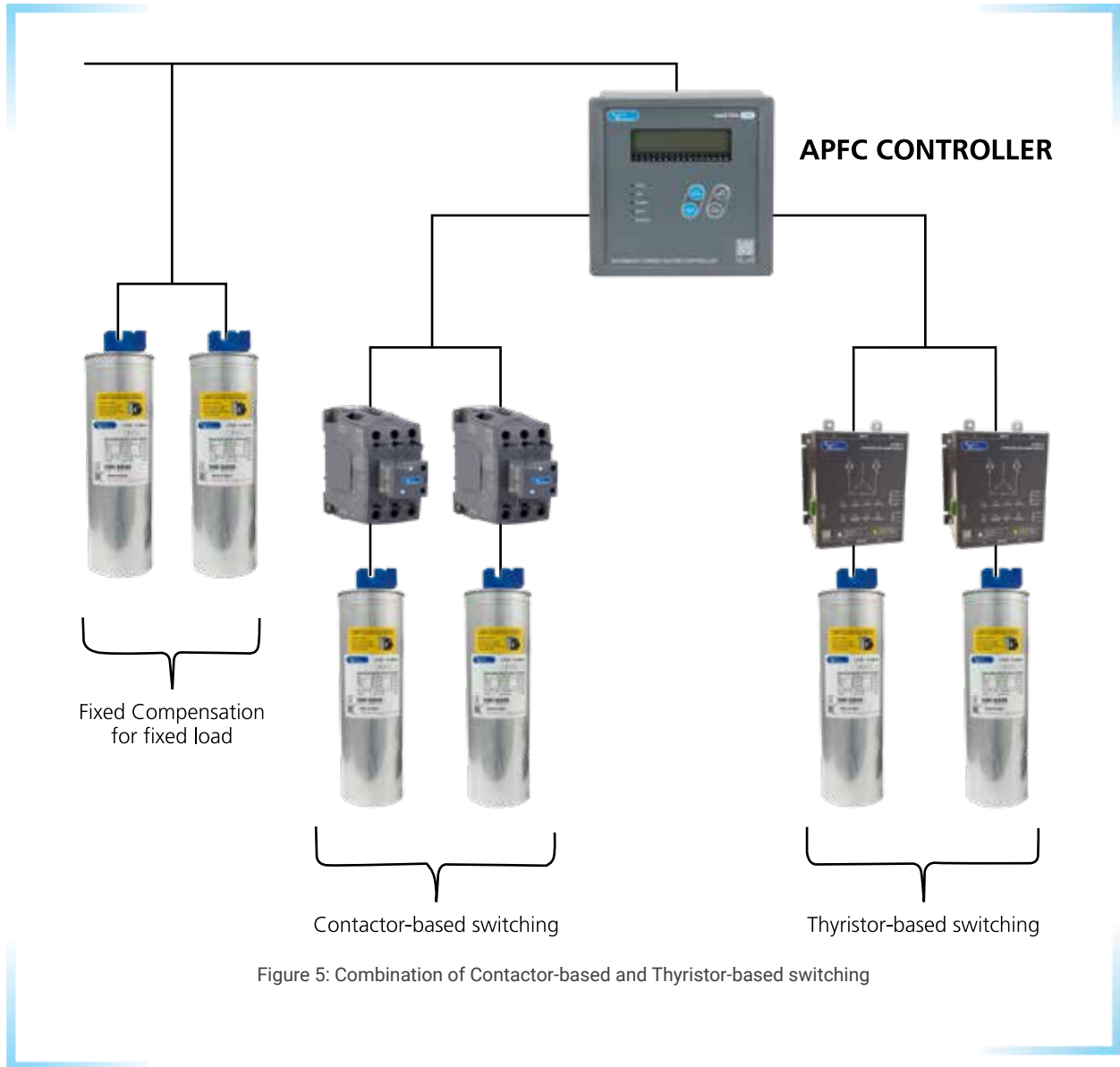

Figure 5: Combination of Contactor-based and Thyristor-based switching

The most economical solution can be to provide some fixed capacitors for the loads that are ON throughout the day, a contactor-based switching for capacitors providing

compensation to varying motor loads and a thyristor-based switching for capacitors providing compensation to highly fluctuating loads.

# Thyristor Switching Modules

In some modern industries, due to special processes with rapidly fluctuating loads, the demand for reactive power also fluctuates rapidly. Usage of mechanical switch (contactors) has the following negative impacts:

- › Average unity power factor cannot be maintained due to delay in capacitor switching
- › Reduction in the life of capacitors, contactors and other equipments
- › Power quality issues due to current and voltage transients

The solution is dynamic power factor correction system.

With the thyristor module we provide the main component - "The Electronic Switch"- for dynamic power factor correction. The LT-TSM series offers fast electronically controlled, self-observing thyristor switches for capacitive loads up to 50 kVAR, that are capable to switch PFC capacitors within a few milliseconds nearly without a limitation to the number of switchings during



the capacitor lifetime. These switching modules are easy to install, have a fast reaction time of 5 msec and come with built-in indications of operations, faults and activation. These thyristor modules are very compact and operate at lower power losses.

## Features

### Component for the design of Dynamic PFC-systems in 415 V and 440 V-grids

- › Automatically adapted by microprocessor to de-tuned and conventional capacitor branches (up to 14 %); therefore optimization of the switching behavior .
- › Available in 10, 25 & 50 kVAR ratings.
- › Monitoring of Supply Voltage & SCR status via LED.
- › Switching without time lag.
- › No system perturbation caused by switching operations
- › No auxiliary supply needed
- › Maintenance free
- › Long operational life
- › High switching speed
- › Enhanced temperature management
- › LED indications
- › Self Test feature for maintenance and checking healthiness of thyristors
- › AUX contacts for thyristor switching status and fault indications
- › Internal signal voltage generation for input signal (reduced wiring)

## Application

Industries and applications with high load fluctuations, where the demand for reactive power is also very dynamic:

- › Welding
- › Elevators and cranes
- › Presses
- › Wind turbines

# Technical Details

| Description                    | LKTSM 10  | LKTSM 25                    | LKTSM 50                    |
|--------------------------------|---|-----------------------------|-----------------------------|
| Cat.Code                       | CS920490000   | CS920500000                 | CS920510000                 |
| Rating ( kVAr )                | 10  | 25                          | 50                          |
| Rated Voltage (V)              | 440   |                             |                             |
| Rated Frequency (Hz)           | 50 / 60   |                             |                             |
| Power Losses (W)               | 35  | 75                          | 150                         |
| Peak Inverse Voltage - PIV (V) | 2200  |                             |                             |
| Operating temperature (°C)     | -10° to +55°  |                             |                             |
| Control DC Supply (Vdc)        | 10-30   |                             |                             |
| Reaction Time (ms)             | 5   |                             |                             |
| Re-switching time (ms)         | 60  |                             |                             |
| LED Indication                 | "POWER : Operating voltage activated (Green LED)<br>COMMAND : Command Activated (Red LED)<br>THYRISTOR 1 : Thyristor 1 command ON (Yellow LED)<br>THYRISTOR 2 : Thyristor 2 command ON (Yellow LED)<br>SELF TEST : Self-Test (Green LED)<br>OVER/UNDER VOLTAGE : Under Voltage fault - Blinking RED LED<br>Over Voltage Condition- Steady RED LED<br>CAPACITOR FAULT : Capacitor load not connected / Disconnected<br>OVER TEMPERATURE : Heat Sink temperature too high (Red LED) |                             |                             |
| Protection                     | Over Temperature Protection (°C) > 85 ± 20%<br>Under Voltage Protection (V a.c.) < 330 ± 20%<br>Over Voltage Protection (V a.c.) > 500 ± 20%  |                             |                             |
| Monitoring                     | "Permanent monitoring of supply voltage, temperature and thyristor operation status<br>(Note: Before re-switching after temperature fault, heat sink temperature must be below 50°C)  |                             |                             |
| Termination                    | Cu Busbar (Input supply - Top side "L1 & L3") ;(Output Load - Bottom side "C1& C3")   |                             |                             |
|                                | Cable size - 4 sq. mm (CU)  | Cable size - 16 sq. mm (CU) | Cable size - 35 sq. mm (CU) |
|                                | Torque - 0.5- 0.6 Nm  |                             | Torque- Min 2 - Max 4 Nm    |
| Protection                     | Semiconductor fuse (High speed fuse) is mandatory for short circuit protection.   |                             |                             |
|                                | 10 kVAr : 32 A  | 25 kVAr : 80 A              | 50 kVAr : 160 A             |
| Capacitor Discharge Resistor   | Quick discharge resistors (Default capacitor discharge resistors shall be interchanged with QDR)  |                             |                             |
| Mounting Position              | Vertical, minimum 150 mm space clearance around the module (Follow Zig-Zag mounting in panel)   |                             |                             |
| Standard compliance            | IEC 60947-4-3   |                             |                             |
| <b>Note</b>                    | Capacitor fault indication is active only when the product is in OFF STATE.<br>Detuned / 0.2% series reactors are mandatory with TSM Switching device   |                             |                             |

## Selection of TSM and Semiconductor Fuse

| Capacitor Step (kVAr) | Rated Current (A) | TSM Rating (kVAr) | I <sup>2</sup> t Rating | Semi-conductor fuse rating (A) | Semi-conductor fuse Model | Cable Size |
|-----------------------|-------------------|-------------------|-------------------------|--------------------------------|---------------------------|------------|
| 5                     | 6.6               | 10                | 11000                   | 16                             | FWP-20A14F                | 4 Sq.mm    |
| 10                    | 13.1              | 10                | 11000                   | 32                             | FWP-32A14F                | 4 Sq.mm    |
| 12.5                  | 16.4              | 25                | 14500                   | 40                             | FWP-40A14F/40A22F         | 16 Sq.mm   |
| 15                    | 19.7              | 25                | 14500                   | 50                             | FWP-50A14F/ 50A22F        | 16 Sq.mm   |
| 20                    | 26.2              | 25                | 14500                   | 63                             | FWP-63A14F/63A22F         | 16 Sq.mm   |
| 25                    | 32.8              | 25                | 14500                   | 80                             | FWP-80A22F                | 16 Sq.mm   |
| 30                    | 39.4              | 50                | 14500                   | 96                             | FWP-100A22F               | 35 Sq.mm   |
| 35                    | 45.9              | 50                | 14500                   | 110                            | 110EET                    | 35 Sq.mm   |
| 40                    | 52.5              | 50                | 14500                   | 120                            | 120FEE                    | 35 Sq.mm   |
| 50                    | 65.6              | 50                | 14500                   | 160                            | 160EET                    | 35 Sq.mm   |
| 75                    | 98.4              | 3 nos. of 25      | 3 nos. of 14500         | 3 nos. of 80 A                 | -                         | -          |
| 100                   | 131.2             | 2 nos. of 50      | 2 nos. of 14500         | 2 nos. of 160 A                | -                         | -          |

**Note:** The I<sup>2</sup>t rating of the semiconductor fuse should be less than that of the device.

# Network of Thyristor Switching Modules

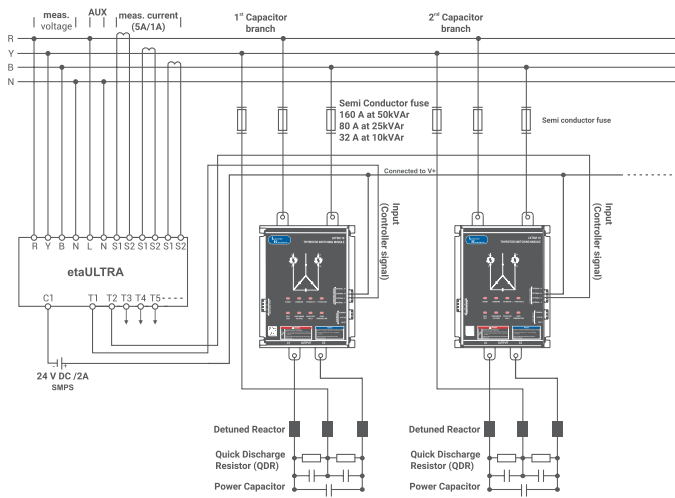

WIRING DIAGRAM FOR MULTI TSM WITH EXTERNAL POWER SUPPLY

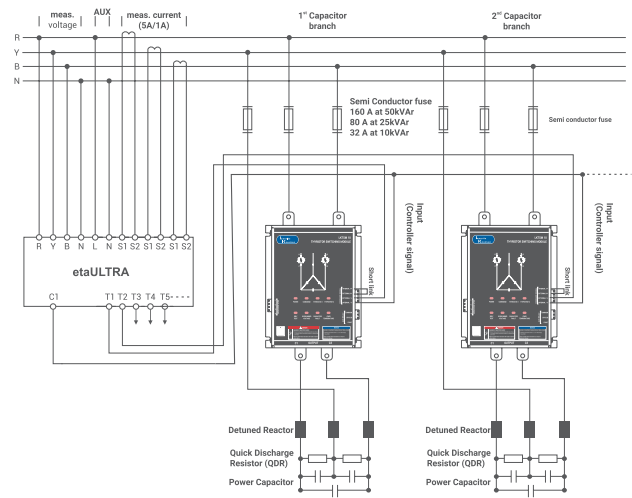

WIRING DIAGRAM FOR MULTI TSM WITH INTERNAL POWER SUPPLY

## Putting into operation

After switching on the net voltage (engaging of the branch fuse) the thyristor module is ready for operation. Following tests and setting are performed when switching on the voltage:

- > control of control voltage (operating voltage module)
- > automatic setting to net frequency (50 or 60 Hz)

### 1) Understanding LED Indications for 10kVAr, 25 & 50kVAr

The thyristor module includes 8 leds with the following meanings

**Note:** unless otherwise specified the red/green & yellow leds will display a steady indication.

- POWER : ● Operating voltage activated
- COMMAND : ● Command Activated
- THYRISTOR 1 : ● Thyristor 1 command ON
- THYRISTOR 2 : ● Thyristor 2 command ON
- SELF TEST : ● Self-Test
- OVER/UNDER VOLTAGE : ● Under Voltage fault - Blinking RED LED  
Over Voltage Condition- Steady RED LED
- CAPACITOR FAULT : ● Capacitor load not connected / Disconnected
- OVER TEMPERATURE : ● Heat Sink temperature too high (Over temperature > 85 °C ± 10%)

## MOUNTING DETAILS

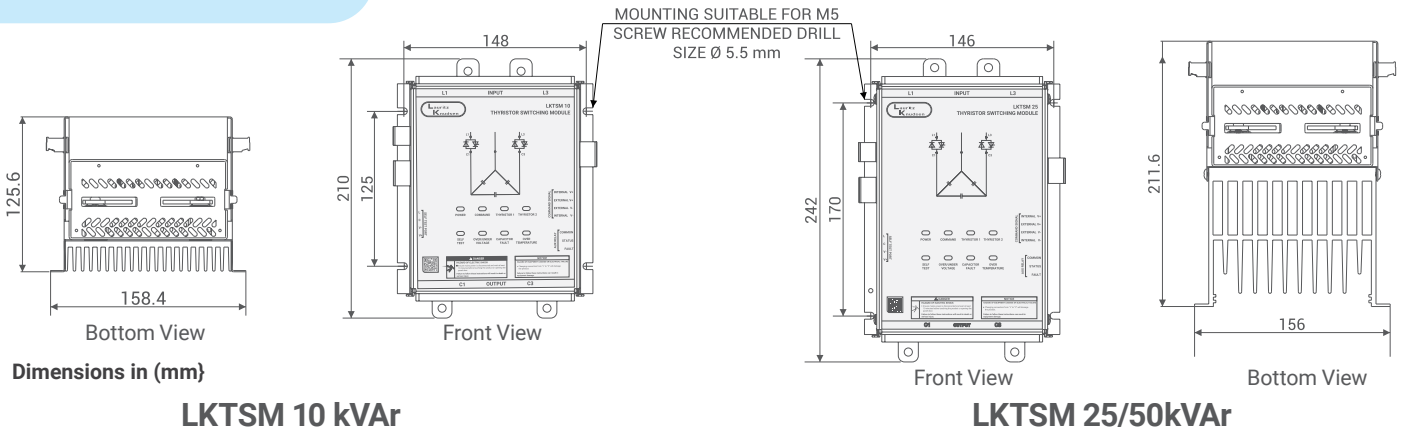

Dimensions in (mm)

LKTSM 10 kVAr

LKTSM 25/50kVAr

| Rating in kVAr | Weight in kg | Max. RMS Current (A) | Cat. Nos.   | Tightening Torque | Max. Palm Width | Lug Termination |
|----------------|--------------|----------------------|-------------|-------------------|-----------------|-----------------|
| 10             | 2            | 20                   | CS920490000 | 5.2 Nm            | 12 mm           | Ring type       |
| 25             | 4.8          | 50                   | CS920500000 | 5.2 Nm            | 12 mm           |                 |
| 50             | 4.58         | 100                  | CS920510000 | 5.2 Nm            | 12 mm           |                 |

### WARNING

Use the recommended semiconductor fuse. Do not bypass the fuse under any conditions  
 The devices must be protected against humidity and dust; sufficient ventilation must be assured.  
 The earthing conductor must be connected to the screw provided for earthing before connecting the supply.

# Power factor correction – now easier than ever

Brought to you by Lauritz Knudsen - India's largest manufacturer of LT switchgear - the etaSMART & etaULTRA Series automatically corrects the power factor, with the help of contactor & thyristor for the connection and disconnection of capacitor banks.

Packed with a specially formulated optimisation program, the controller ensures accurate power factor control at the set point and hunt free operation.

## etaULTRA Series - 3 CT Input

### The E&A Advantage - etaULTRA

- › 3- Phase Current and Voltage measurement
- › Available upto 16 steps
- › Cascading - Master-slave configuration possible to increase contact output up to 64 steps
- › Dual PF setting for Mains-DG application
- › Individual harmonics measurement up to 31st order
- › PF setting - up to 3rd digit after decimal
- › Display of voltage angles and current angles for ease of troubleshooting
- › Site selectable 2 or 4 quadrant operation for industries with or without Solar plants



## etaSMART Series - 1 CT Input

### The E&A Advantage - etaSMART

- › Available upto 16 steps
- › Space-saving. Compact size of 96 x 96 mm for controller upto 8 steps
- › CT Secondary 1A/5A
- › Automatic detection of CT polarity saves time and effort. etaSMART detects the CT reversal and automatically corrects it
- › Option of LIFO, FIFO, and Intelligent control mode
- › Site selectable 2 or 4 quadrant operation for industries with or without Solar plants
- › Capacitor health check monitoring function ensures that capacitor is declared faulty if its power falls beyond a certain limit
- › Last relay output contact can be configured as Step or Alarm. Second-last relay output can be configured as Step or Fan control
- › Ambient temperature monitoring via internal sensor



# Technical Specifications

| Parameters                 | etaSMART (1 CT)  |                                 | etaULTRA (3 CT)   |  |
|----------------------------|--|---------------------------------|---|--|
|                            | etaSMART R<br>(Contactor logic)  | etaSMART T<br>(Thyristor logic) | etaULTRA R<br>(Contactor logic)   | etaULTRA T<br>(Thyristor + Contactor)  |
| Voltage input (L - L)      | 415 - 440 VAC  |                                 | 50 - 760 VAC  |  |
| Aux. supply                | -  |                                 | 85 - 300 VAC/ DC  |  |
| Current input              | 1A / 5A  |                                 | 1A / 5A   |  |
| Rated frequency            | 50 - 60 Hz   |                                 | 50 - 60 Hz  |  |
| No of output contact       | 4, 6, 8, 12, 14, 16<br>(For Contactor)   | 6, 8, 12, 15<br>(For Thyristor) | 6, 8, 12, 15<br>(For Thyristor)   | 8T + 2R, 14T + 2R, 8T + 8R<br>(T for Thyristor switching, R for Contactor switching) |
| Output contact rating      | Relay, 250 VAC @ 5A  | Thyristor, 8 - 48 VDC @ 100 mA  | Relay, 250 VAC @ 5A   | Relay, 250 VAC @ 5A<br>Thyristor, 8 - 48 VDC @ 100 mA                                |
| Communication interface    | -  |                                 | Modbus RTU (RS 485)   |  |
| Cascading                  | -  |                                 | Upto 64 steps in master slave configuration   |  |
| Display parameter          | PF, V, I, Required KVA <sub>r</sub> , KVA, KW, KVA <sub>r</sub> , V-THD, I-THD, Hz, Temperature.   |                                 | System PF, V, I, Required KVA <sub>r</sub> , Voltage angles, Current angles, KVA, KW, KVA <sub>r</sub> , V-THD, I-THD, Hz, Individual harmonics upto 31st order, Temperature            |  |
| Control power factor range | 0.3 Lag to 0.3 Lead  |                                 | 0.3 Lag to 0.3 Lead   |  |
| Dual PF setting            | -  |                                 | Target PF 1 - Default Target PF 2 -Based on Digital input   |  |
| Digital input              | -  |                                 | 2 Digital Inputs, Programmable Range:65-285   |  |
| Alarms                     | Over / Under compensation, Over / Under voltage, Over / Under Current, High V - THD, High I - THD, Over / Under frequency, Over temperature. |                                 | Over / Under compensation, Over / Under voltage, Over / Under Current, High V - THD, High I - THD, Over / Under frequency, Over temperature, Modbus fail alarm, Capacitor faulty alarm. |  |
| Power consumption          | 7.5 VA   |                                 | 5.0 VA  |  |
| Relative humidity          | < 90 %   |                                 | < 90 %  |  |
| Mounting                   | Flush  |                                 | Flush   |  |
| Degree of protection       | IP 20 (Front IP 54)  |                                 | IP 20 (Front IP 54)   |  |
| Operating temperature      | 20° to +60° C  |                                 | 20° to +60° C   |  |
| Storage temperature        | 30° to +80° C  |                                 | 30° to +80° C   |  |
| Humidity                   | 0 to 90%   |                                 | 0 to 90%  |  |
| Compliances                | EN 61010-1, IEC/EN 61000 - 6 - 2, IEC/EN 61000 - 6 - 4, EN 61326.  |                                 | EN 61010-1, IEC/EN 61000 - 6 - 2, IEC/EN 61000 - 6 - 4, EN 61326.   |  |

# Product Dimensions

## etaSMART 4R, etaSMART 6R, etaSMART 8R and etaSMART 6T

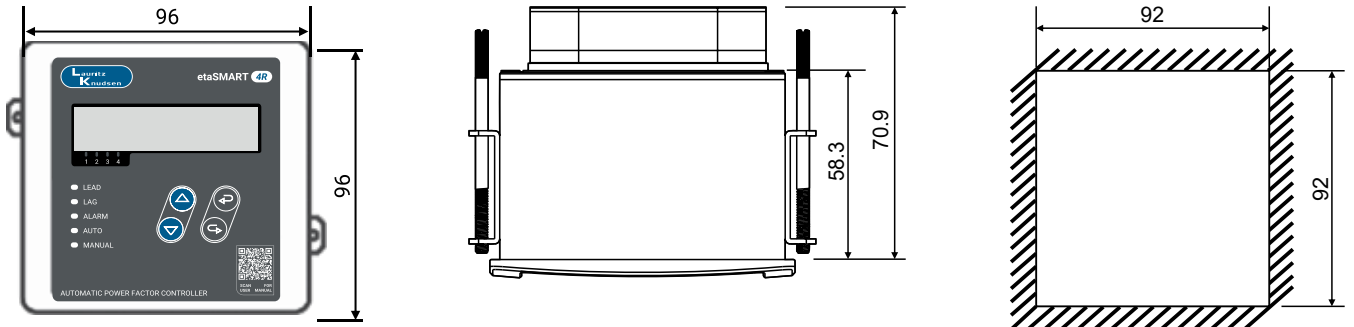

## etaSMART 12R, etaSMART 14R, etaSMART 16R, etaSMART 8T, etaSMART 12T and etaSMART 15T

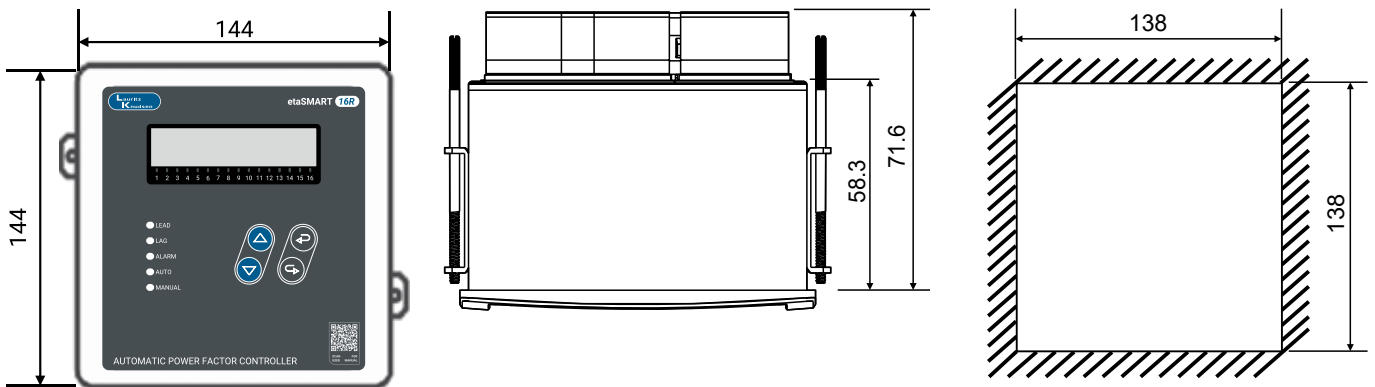

## etaULTRA 8R, etaULTRA 16R, etaULTRA 8T+2R, etaULTRA 14T+2R & etaULTRA 8T+8R

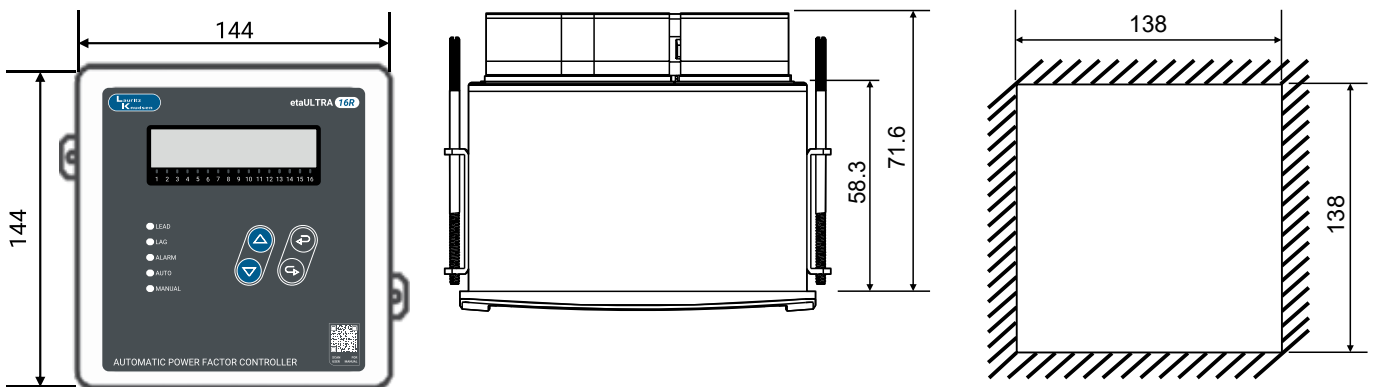

NOTE: All dimensions are in mm

# 4.2 Wiring Diagram

## etaSMART 4R, etaSMART 6R, etaSMART 8R

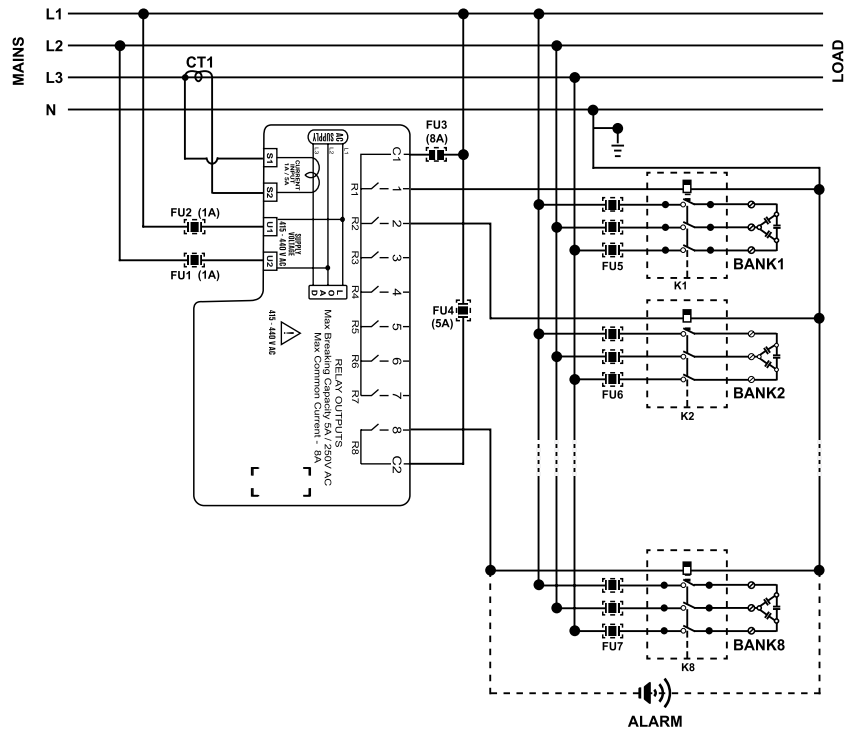

## etaSMART 12R, etaSMART 14R, etaSMART 16R

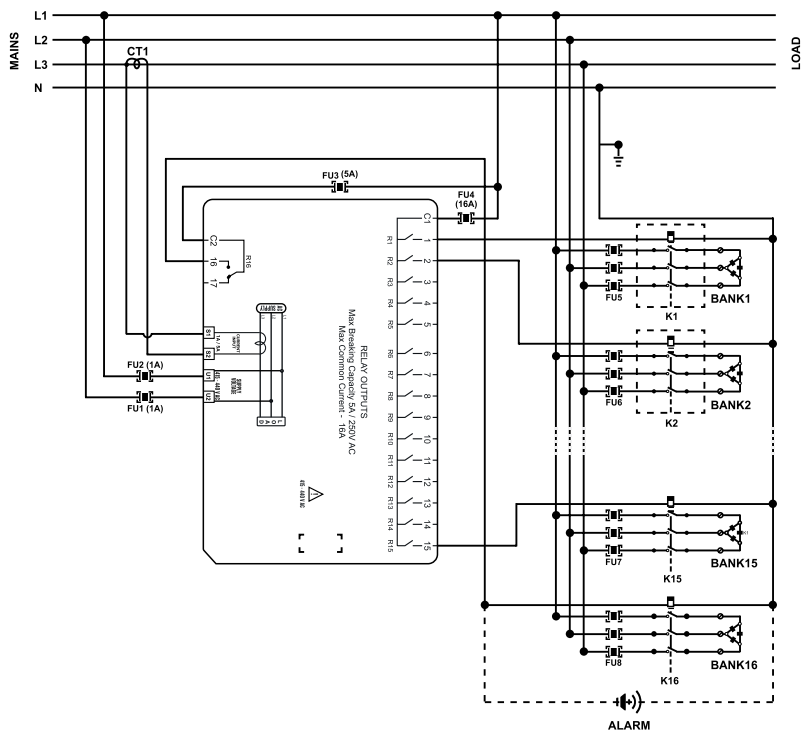

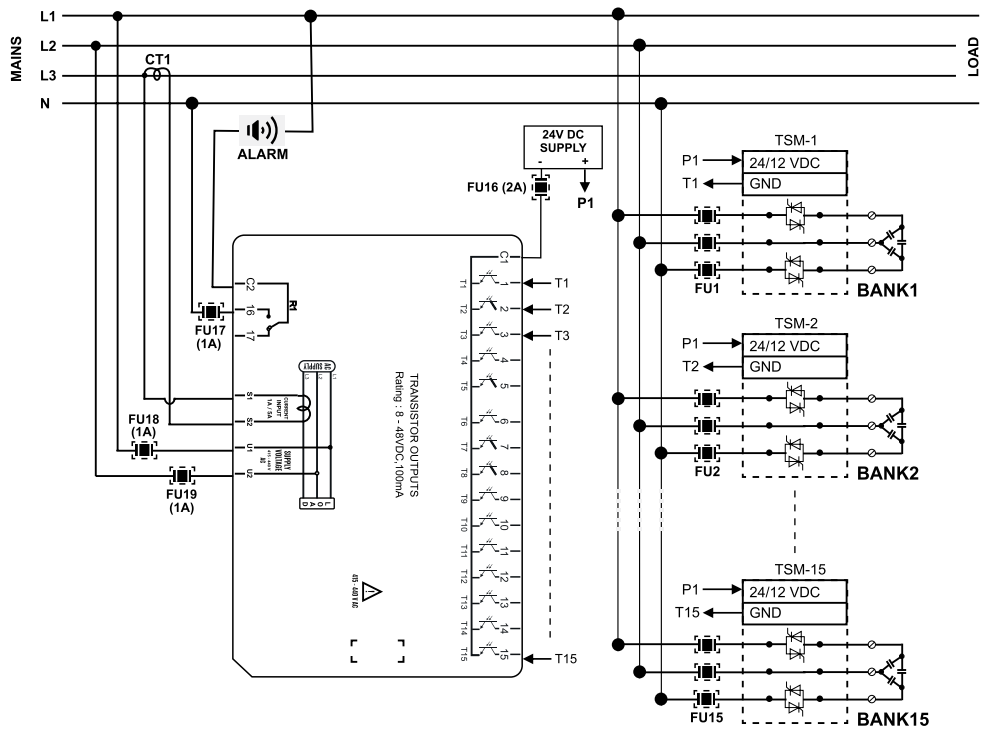
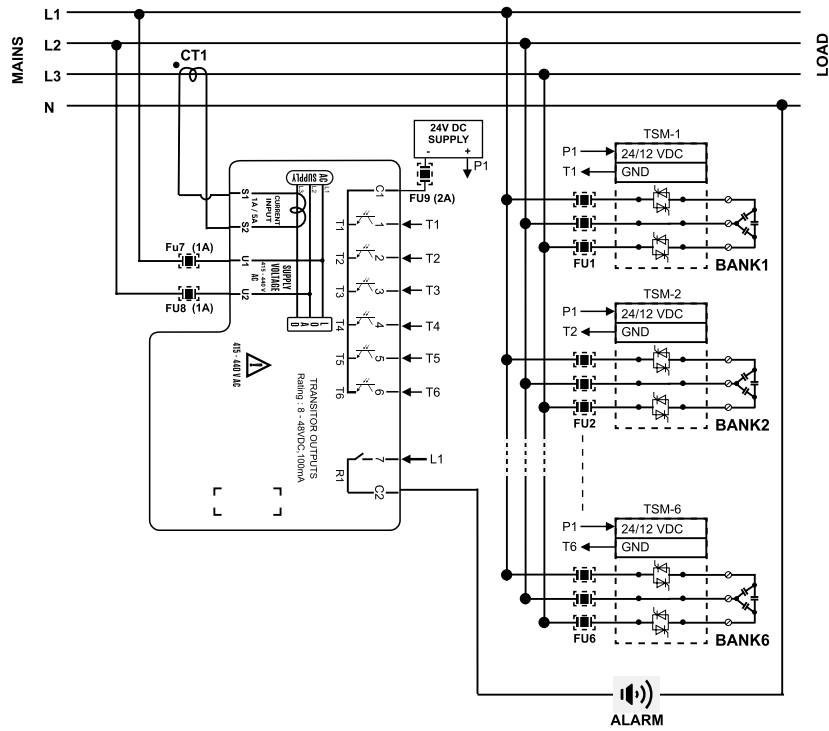

## etaULTRA 8R, etaULTRA 16R

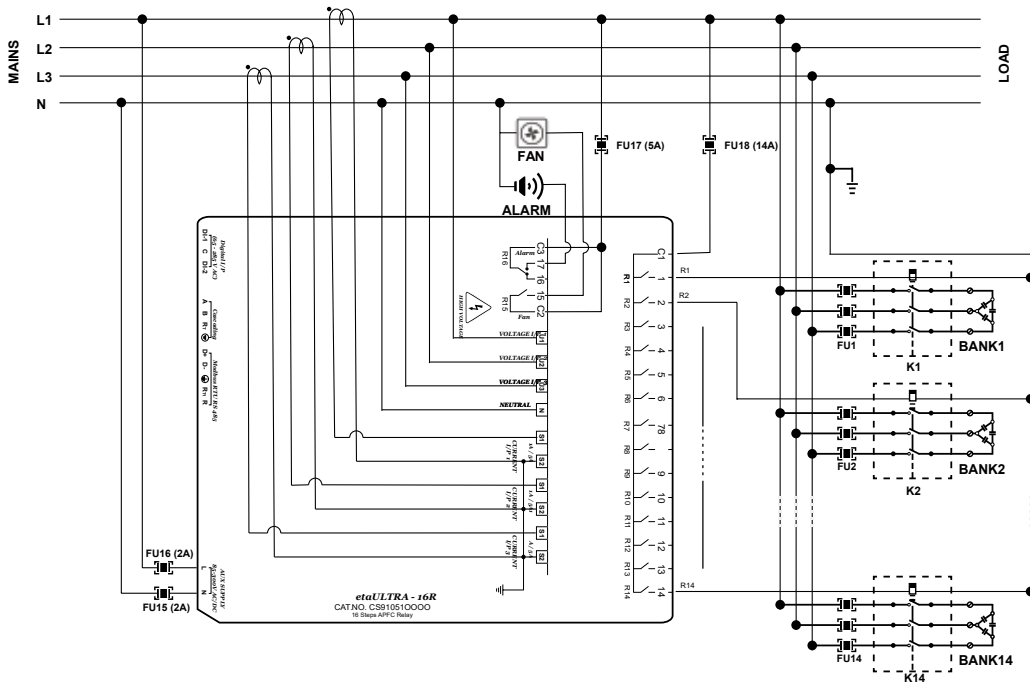

### NOTE:

1. Last two relay output contacts can be configured either to switch the capacitor bank or to energise FAN and ALARM respectively as shown in wiring diagram.
2. All relay terminals, Voltage & current input terminals are suitable for wire range 12-30 AWG stranded or Solid copper wire. Modbus and cascading terminals are suitable for 14-30 AWG

## etaULTRA 14T+2R

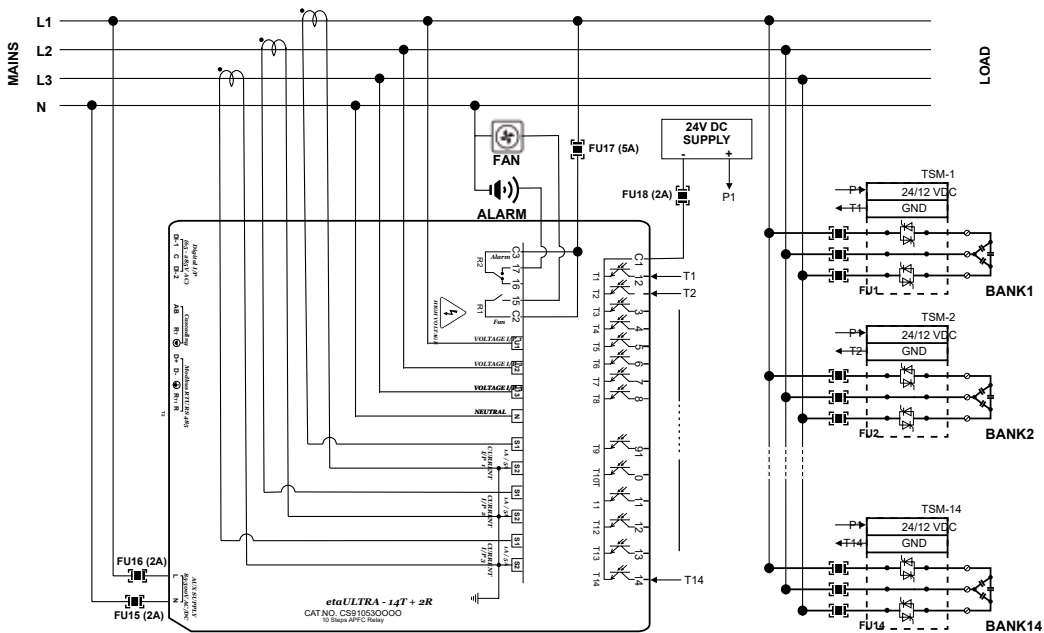

### NOTE:

1. Last two relay output contacts can be configured either to switch the capacitor bank or to energise FAN and ALARM respectively as shown in wiring diagram.
2. All relay terminals, Voltage & current input terminals are suitable for wire range 12-30 AWG stranded or Solid copper wire. Modbus and cascading terminals are suitable for 14-30 AWG

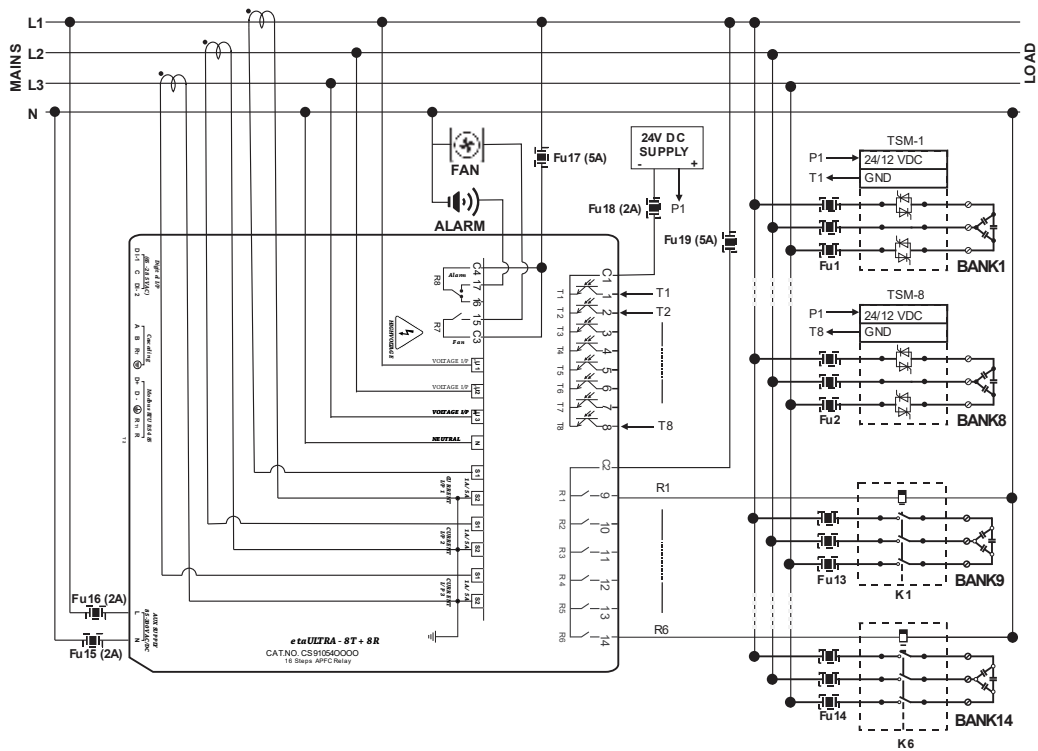

**NOTE:**

1. Last two relay output contacts can be configured either to switch the capacitor bank or to energise FAN and ALARM respectively as shown in wiring diagram.
2. All relay terminals, Voltage & current input terminals are suitable for wire range 12-30 AWG stranded or Solid copper wire. Modbus and cascading terminals are suitable for 14-30 AWG

# Salient features of - etaULTRA



## MANUAL & AUTOMATIC OPERATION

- › In auto mode, just initiate AUTO PROGRAM and the controller will configure itself or we can also configure it manually with few simple steps.



## CONTROL MODE

- › Option of UFO, FIFO, and Intelligent control mode. Choose any of these control modes. By default, it is set as intelligent; this mode selects the best with combination of capacitor bank for compensation with minimum switching to achieve the desired power factor



## POWER QUALITY INFORMATION

- › Instant information on the quality of your power system, etaULTRA measures current THD, and alerts you if levels go beyond set limits.



## CAPACITOR HEALTH CHECK

- › Capacitor health check monitoring function ensures that capacitor is declared faulty if its power falls beyond a certain limit.



## RECORD OF STEP-SWITCHING

- › You can schedule the maintenance of your installation by reading the record of the number of switching of each step.



## AMBIENT TEMPERATURE MONITORING

- › Ambient Temperature Monitoring via Internal Sensor.



### DISPLAY OF CURRENT & VOLTAGE ANGLES

- › Display of current & Voltage angles helps to troubleshoot the wiring-related problem.



### HT Sensing

- › The wide band of input voltage measurement allows etaULTRA to sense the HT voltage with the help of voltage transformers.



### CASCADING OF etaULTRA CONTROLLERS

- › The cascading feature allows the user to extend the output contacts up to 64 output contacts in a master-slave configuration.



### DUAL PF (DIGITAL INPUT BASED)

- › etaULTRA comes with 2 target Power Factor set points, Target PF 1 maintains mains/ EB PF and target PF 2 maintains DG PF.



### INBUILT RS485

- › etaULTRA comes with an inbuilt RS485 port which allows for seamless digital connectivity.



### SITE SELECTABLE 2Q/ 4Q OPERATION

- › With the help of 4 quadrant operation etaULTRA can maintain PF in site with or without solar plant.

# Salient features of - etaSAMRT



## MANUAL & AUTOMATIC OPERATION

- › In auto mode, just initiate AUTO PROGRAM and the controller will configure itself or we can also configure it manually with few simple steps.



## CONTROL MODE

- › Option of UFO, FIFO, and Intelligent control mode. Choose any of these control modes. By default, it is set as intelligent; this mode selects the best with combination of capacitor bank for compensation with minimum switching to achieve the desired power factor.



## POWER QUALITY INFORMATION

- › Instant information on the quality of your power system, etaULTRA measures current THD, and alerts you if levels go beyond set limits.



## CAPACITOR HEALTH CHECK

- › Capacitor health check monitoring function ensures that capacitor is declared faulty if its power falls beyond a certain limit.



## RECORD OF STEP-SWITCHING

- › You can schedule the maintenance of your installation by reading the record of the number of switching of each step.



## AMBIENT TEMPERATURE MONITORING

- › Ambient Temperature Monitoring via Internal Sensor.



### SITE SELECTABLE 2Q/ 4Q OPERATION

- › With the help of 4 quadrant operation etaSMART can maintain PF in site with or without solar plant.

## Application based Product selection

| Application  | Available variant        |
|--|--------------------------|
| For balanced load/ 1CT   | etaSMART series          |
| For Unbalance load/ 3CT  | etaULTRA series          |
| For Fast fluctuating load/ Thyristor switching/<br>Real-time switching | etaSMART T or etaULTRA T |
| For Solar application/ 4 quadrant operation                            | etaSMART & etaULTRA      |
| Controller for more than 16 steps                                      | etaULTRA                 |
| HT Sensing   | etaULTRA                 |
| Dual PF – DI based   | etaULTRA                 |
| Communication – Inbuilt Rs485  | etaULTRA                 |

## Guidelines-CT selection and placement

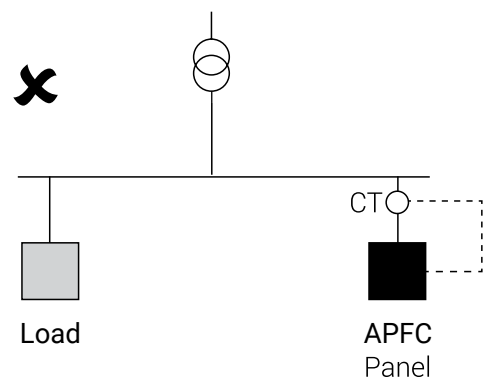
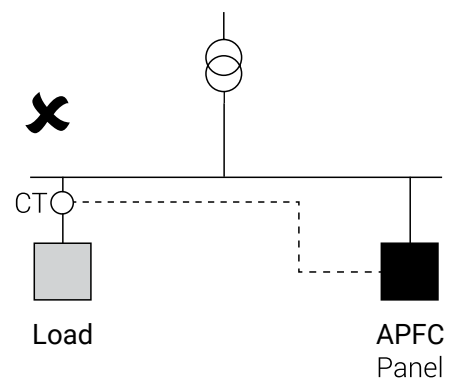
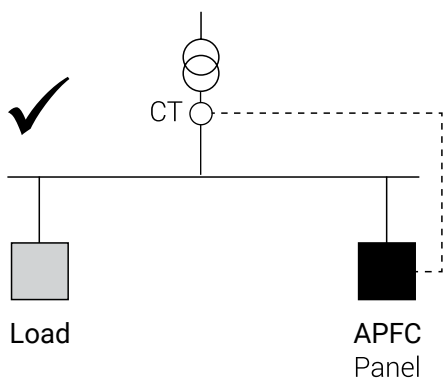

Recommendation - Use CT with 1 Amp secondary in case the distance between CT and Controller is more than 10 meter

**NOTE:** Capacitor duty contactor must be used for capacitor switching

# Application note



IS YOUR EXISTING APFC PANEL ABLE TO MAINTAIN THE TARGET POWER FACTOR  
**UNDER FLUCTUATING LOAD CONDITIONS?**

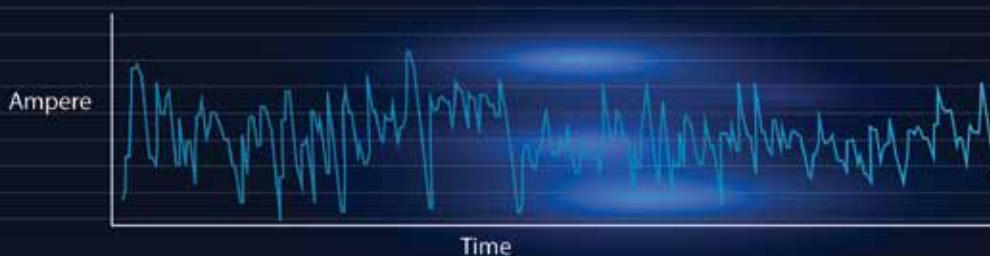

**If the APFC Panel is not designed to take care of these fluctuating load conditions, result is:**

**Low Monthly PF**  
Average PF 0.82\*

**High Electricity Bill**  
PF Penalty – ₹ 78,541.00\*

Lauritz Knudsen Electrical & Automation brings to you customised solutions  
For Dynamic Power Factor Correction Systems.

**etaSMART T**  
Single CT APFC Controller



**etaULTRA T**  
Three CT APFC Controller



**For Thyristor switched APFC Panels**

Ensure significant improvement in monthly PF in case of fluctuating loads.

## POWER FACTOR CONTROL IN UNBALANCED LOAD CONDITIONS

**PROBLEM** ▶ How to control Power Factor in case of Unbalanced Load Conditions?

**SOLUTION** ▶ APFC Controller with 3 CT inputs.  
Controller with 3 CT inputs calculate average value of current. This results into better Power Factor than that with 1 CT input.



# etaULTRA

3 CT APFC controller for contactor and thyristor based APFC Panels.

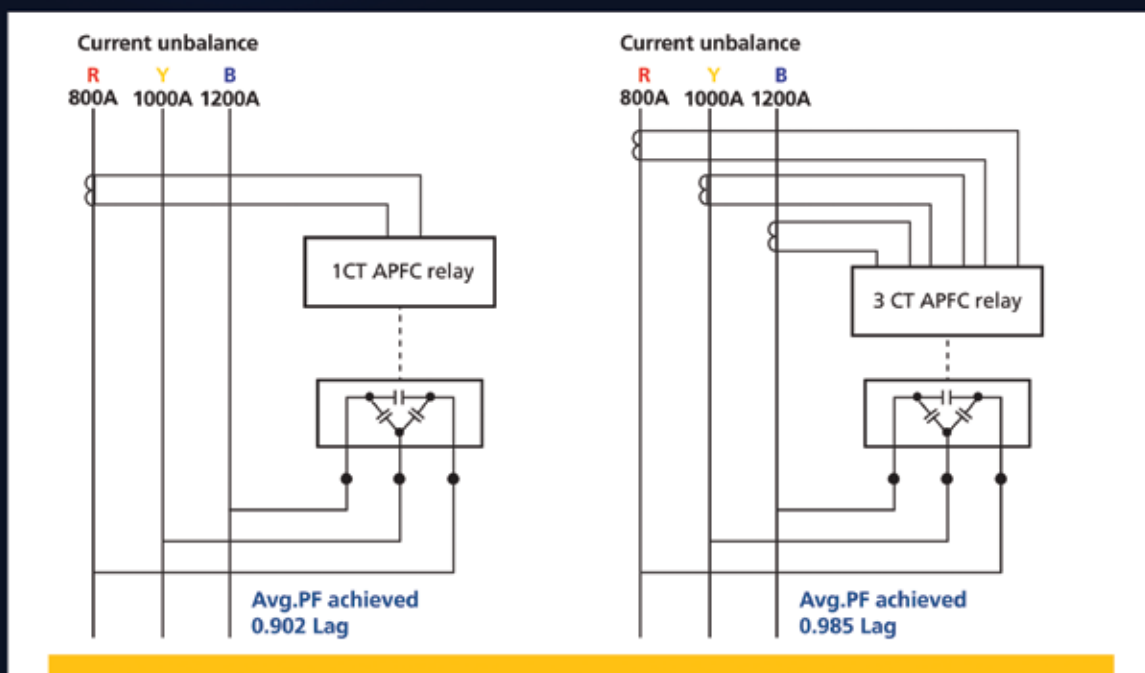

**Conclusion-** In unbalance load conditions, average PF achieved with 3 CT controller is better than 1 CT controller.

Note: Value of current and PF are for representation only.

## CASCADING OF APFC CONTROLLERS

**Requirement - APFC Panel with more than 16 steps.**

**PROBLEM** ▶ Use of 2 separate APFC controllers lead to hunting of contactors and malfunction of APFC Panel.

**SOLUTION** ▶ Cascading of APFC Controllers. Multiple APFC controllers with Cascading [Master – slave logic] can be connected together to offer higher number of steps.

Introducing } **etaULTRA**

3 CT APFC controller with inbuilt cascading facility

**etaULTRA 16R  
Master**

**etaULTRA 16R  
Slave**



etaULTRA can offer up to 64 steps with cascading of 4 controllers.

\*Numbers are just for representation.

# Selection of Capacitor - 5 Step Approach

Power Factor Correction Capacitors have been used for many years as the most cost effective solution for PF improvement. Modern electrical networks are continuously evolving into more complex installations due to the increasing usage of non-linear loads, sophisticated control & automation, UPS systems, energy efficiency improvement devices etc.

This evolution is also accompanied by increased dependency on captive power generation as well as growing concerns about incoming supply power quality.

In this background, it is necessary to evolve the Power Factor Correction solution also to a higher level so as to ensure sustainable achievement of high PF & acceptable harmonic distortion levels. The selection of the correct type of PFC capacitors & filter reactors thus needs better understanding of the various issues involved.

This publication outlines a "5 Step" technology based approach, simplified for easier understanding to enable the correct selection of PFC Capacitors & Filter Reactors.

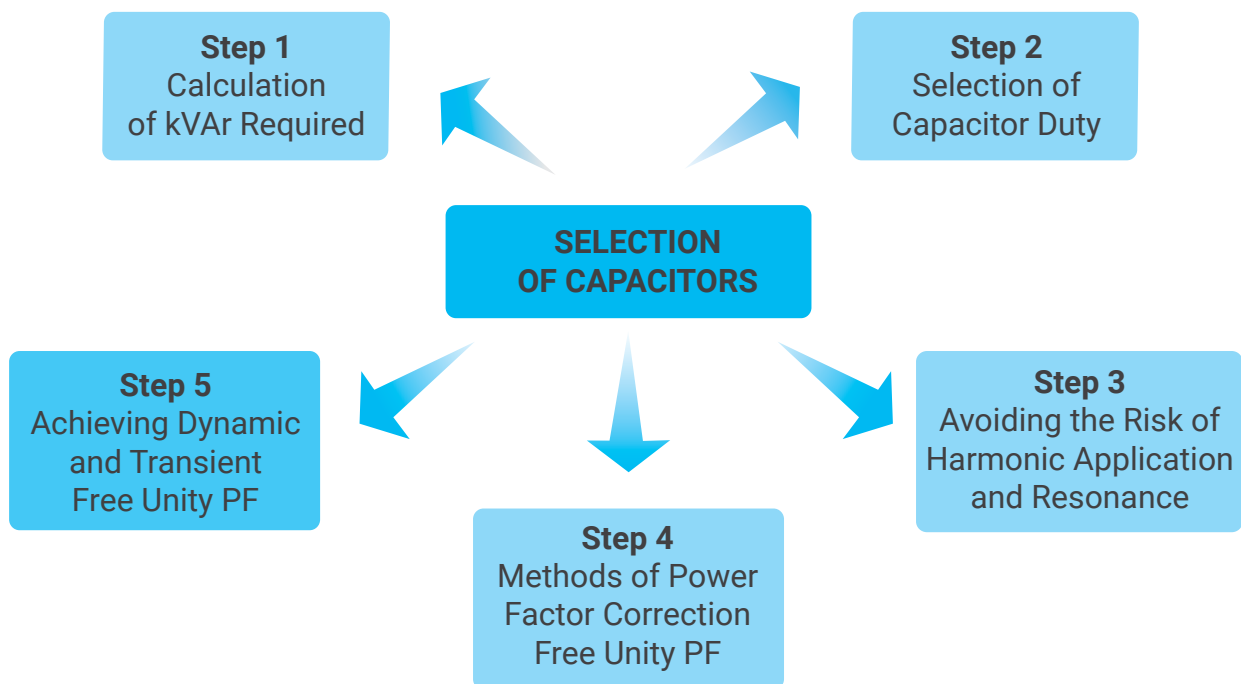

## STEP 1: Calculation of kVAr Required for Industries & Distribution Networks

In electrical installations, the operating load kW and its average power factor (PF) can be ascertained from the electricity bill. Alternatively, it can also be easily evaluated by the formula:

$$\text{Average PF} = \frac{\text{kW}}{\text{kV A}}$$

$$\text{Operating load kW} = \text{kV A Demand} \times \text{Average PF}$$

The average PF is considered as the initial PF and the final PF can be suitably assumed as target PF. In such cases, required capacitor kV Ar can be calculated as explained in the example below:

Example: To calculate the required kVAr compensation for a 500 kW installation to improve the PF from 0.75 to 0.96

$$\text{kV Ar} = \text{kW} \times \text{multiplying factor from table} = 500 \times 0.590 = 295 \text{ kV Ar}$$

$$\text{kVAr required} = \text{kW} (\tan\theta_2 - \tan\theta_1)$$

where

$$\theta_1 = \cos^{-1}(\text{PF}_1) \text{ and } \theta_2 = \cos^{-1}(\text{PF}_2)$$

## Step 1: Calculation of kVAr Required

| Target PF/<br>Initial PF | 0.9   | 0.91  | 0.92  | 0.93  | 0.94  | 0.95  | 0.96  | 0.97  | 0.98  | 0.99  |
|--------------------------|-------|-------|-------|-------|-------|-------|-------|-------|-------|-------|
| 0.4                      | 1.807 | 1.836 | 1.865 | 1.896 | 1.928 | 1.963 | 2.000 | 2.041 | 2.088 | 2.149 |
| 0.42                     | 1.676 | 1.705 | 1.735 | 1.766 | 1.798 | 1.832 | 1.869 | 1.910 | 1.958 | 2.018 |
| 0.44                     | 1.557 | 1.585 | 1.615 | 1.646 | 1.678 | 1.712 | 1.749 | 1.790 | 1.838 | 1.898 |
| 0.46                     | 1.446 | 1.475 | 1.504 | 1.535 | 1.567 | 1.602 | 1.639 | 1.680 | 1.727 | 1.788 |
| 0.48                     | 1.343 | 1.372 | 1.402 | 1.432 | 1.465 | 1.499 | 1.536 | 1.577 | 1.625 | 1.685 |
| 0.5                      | 1.248 | 1.276 | 1.306 | 1.337 | 1.369 | 1.403 | 1.440 | 1.481 | 1.529 | 1.590 |
| 0.52                     | 1.158 | 1.187 | 1.217 | 1.247 | 1.280 | 1.314 | 1.351 | 1.392 | 1.440 | 1.500 |
| 0.54                     | 1.074 | 1.103 | 1.133 | 1.163 | 1.196 | 1.230 | 1.267 | 1.308 | 1.356 | 1.416 |
| 0.56                     | 0.995 | 1.024 | 1.053 | 1.084 | 1.116 | 1.151 | 1.188 | 1.229 | 1.276 | 1.337 |
| 0.58                     | 0.920 | 0.949 | 0.979 | 1.009 | 1.042 | 1.076 | 1.113 | 1.154 | 1.201 | 1.262 |
| 0.6                      | 0.849 | 0.878 | 0.907 | 0.938 | 0.970 | 1.005 | 1.042 | 1.083 | 1.130 | 1.191 |
| 0.62                     | 0.781 | 0.810 | 0.839 | 0.870 | 0.903 | 0.937 | 0.974 | 1.015 | 1.062 | 1.123 |
| 0.64                     | 0.716 | 0.745 | 0.775 | 0.805 | 0.838 | 0.872 | 0.909 | 0.950 | 0.998 | 1.058 |
| 0.66                     | 0.654 | 0.683 | 0.712 | 0.743 | 0.775 | 0.810 | 0.847 | 0.888 | 0.935 | 0.996 |
| 0.68                     | 0.594 | 0.623 | 0.652 | 0.683 | 0.715 | 0.750 | 0.787 | 0.828 | 0.875 | 0.936 |
| 0.7                      | 0.536 | 0.565 | 0.594 | 0.625 | 0.657 | 0.692 | 0.729 | 0.770 | 0.817 | 0.878 |
| 0.72                     | 0.480 | 0.508 | 0.538 | 0.569 | 0.601 | 0.635 | 0.672 | 0.713 | 0.761 | 0.821 |
| 0.74                     | 0.425 | 0.453 | 0.483 | 0.514 | 0.546 | 0.580 | 0.617 | 0.658 | 0.706 | 0.766 |
| 0.75                     | 0.38  | 0.426 | 0.456 | 0.487 | 0.519 | 0.553 | 0.590 | 0.631 | 0.679 | 0.739 |
| 0.76                     | 0.371 | 0.400 | 0.429 | 0.460 | 0.492 | 0.526 | 0.563 | 0.605 | 0.652 | 0.713 |
| 0.78                     | 0.318 | 0.347 | 0.376 | 0.407 | 0.439 | 0.474 | 0.511 | 0.552 | 0.600 | 0.660 |
| 0.8                      | 0.266 | 0.294 | 0.324 | 0.355 | 0.387 | 0.421 | 0.458 | 0.499 | 0.547 | 0.608 |
| 0.82                     | 0.214 | 0.242 | 0.272 | 0.303 | 0.335 | 0.369 | 0.406 | 0.447 | 0.495 | 0.556 |
| 0.84                     | 0.162 | 0.190 | 0.220 | 0.251 | 0.283 | 0.317 | 0.354 | 0.395 | 0.443 | 0.503 |
| 0.85                     | 0.135 | 0.164 | 0.194 | 0.225 | 0.257 | 0.291 | 0.328 | 0.369 | 0.417 | 0.477 |
| 0.86                     | 0.109 | 0.138 | 0.167 | 0.198 | 0.230 | 0.265 | 0.302 | 0.343 | 0.390 | 0.451 |
| 0.87                     | 0.082 | 0.111 | 0.141 | 0.172 | 0.204 | 0.238 | 0.275 | 0.316 | 0.364 | 0.424 |
| 0.88                     | 0.055 | 0.084 | 0.114 | 0.145 | 0.177 | 0.211 | 0.248 | 0.289 | 0.337 | 0.397 |
| 0.89                     | 0.028 | 0.057 | 0.086 | 0.117 | 0.149 | 0.184 | 0.221 | 0.262 | 0.309 | 0.370 |
| 0.9                      |       | 0.029 | 0.058 | 0.089 | 0.121 | 0.156 | 0.193 | 0.234 | 0.281 | 0.342 |
| 0.91                     |       |       | 0.030 | 0.060 | 0.093 | 0.127 | 0.164 | 0.205 | 0.253 | 0.313 |
| 0.92                     |       |       |       | 0.031 | 0.063 | 0.097 | 0.134 | 0.175 | 0.223 | 0.284 |
| 0.93                     |       |       |       |       | 0.032 | 0.067 | 0.104 | 0.145 | 0.192 | 0.253 |
| 0.94                     |       |       |       |       |       | 0.034 | 0.071 | 0.112 | 0.160 | 0.220 |
| 0.95                     |       |       |       |       |       |       | 0.037 | 0.078 | 0.126 | 0.186 |

## Step 2: Selection of Capacitor Duty

The criteria for this classification is based on the following:

Operating life

- › Permissible over voltage & over current coupled with the time duration
- › Number of Switching operations per Year
- › Peak inrush current with standing capability
- › Operating ambient temperature

## Comparison of technical parameters

| Duty                   | Over Current | Permissible Over Voltage @ Rated Voltage 440V | Peak Inrush Currents | Ambient Temperature | Maximum Switching Operations / Year | Life  |
|------------------------|--------------|---|----------------------|---------------------|-------------------------------------|---|
| Standard Duty          | 1.5 x In     | 1.1 Un (8h/24h)                               | 200 x In             | -25°C to 55°C       | 5000                                | 1,00,000 hrs  |
| Heavy Duty             | 1.8 x In     | 1.1 Un (8h/24h)                               | 250/300 x In         | -25°C to 55°C       | 8000                                | 1,50,000 hrs  |
| HD Plus Gas            | 2 x In       | 1.1 Un (8h/24h)                               | 300 x In             | -40°C to 55°C       | 10000                               | 1,80,000 hrs  |
| Super Heavy duty       | 2.5 x In     | 1.1 Un (8h/24h)                               | 350 x In             | -40°C to 65°C       | 15000                               | 2,25,000 hrs at -40°C-60°C;<br>1,50,000 hrs at -40°C-65°C |
| APP                    | 2.5 x In     | 1.1 Un (8h/24h)                               | 350 x In             | -5°C to 55°C        | 10000                               | 2,00,000 hrs  |
| LTXL: Ultra Heavy Duty | 3 x In       | 1.1 Un (8h/24h)                               | 500 x In             | -25°C to 65°C       | 20000                               | 3,00,000 hrs  |

## Step 3: Avoiding the Risk of Harmonic Amplification and Resonance

This step is to make a choice between the use of Capacitors or Capacitors+ Filter reactors. In a system with inductive ( $X_L$ ) and capacitive ( $X_C$ ) impedances, resonance can happen at one particular frequency (resonant frequency,  $f_R$ ).

$$\text{Resonant frequency, } f_R = \frac{1}{(2 \pi \sqrt{LC})}$$

At this point  $X_L$  becomes equal to  $X_C$  and the net impedance becomes very low. Hence, at resonance point, the magnitude of the current (with frequency  $f$ ) is very high and only inherent resistance in the network would limit the current. Typically, the resonance may create major problem in harmonics rich industry. The resonant frequency may match with any of the harmonic frequency and create very high harmonic amplification, which can create huge damage to the electrical equipment.

### Solutions for Current & Voltage Harmonics

| Current Harmonics ( $I_{THD}$ ) | Voltage Harmonics ( $V_{THD}$ ) | Recommended Solutions**  |
|---------------------------------|---------------------------------|--|
| High                            | Low ( $\leq 5\%$ )              | Detuned Harmonic Filter with 480 V (SHD/LTXL) Capacitors and/or Active Harmonic Filter   |
| High                            | High ( $>5\%$ )                 | Detuned Harmonic Filter (High V-THD Withstand*) with 525V (SHD/LTXL Cyl) Capacitors and/or Active Harmonic Filter  |
| Low                             | High ( $>5\%$ )                 | Grid may be polluted with imported voltage harmonics. It may not be possible to reduce them at the load side. Check with utility to rectify. However, Power factor correction can still be achieved with Detuned Harmonic Filter (High V-THD Withstand*) along with 525V capacitors. |

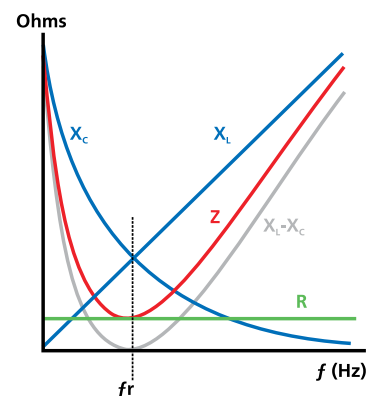

Addition of detuned reactors (in series to capacitors) forcefully shifts the resonant frequency to a safer level.

For example, combination of capacitor and 7% detuned filter reactor has the resonant frequency of 189 Hz, which

## Step 4: Methods of Power Factor Correction

This aims at estimating whether fixed compensation or automatic compensation is to be used.

In order to achieve high power factor i.e., close to unity PF, the following guideline may be adopted to make a decision. If the total kVAr required by the installation is less than 15% of the rating of the incoming supply transformers, then the use of fixed capacitors may be adopted at various points in the installation.

If the kVAr required by the installation is more than 15% of the rating of the incoming supply transformers, then automatic power factor correction solution needs to be adopted.

APFC panels with suitable kVAr outputs may be distributed and connected across various points within the installation.

### Methods of Power Factor Compensation

| Motor (hp)   | Individual Compensation                                     | Group Compensation   | Central Compensation                                     |
|--|---|--|--|
| Control  | Manual / Semi-automatic                                     | Manual / Semi-automatic                                      | Automatic  |
| Elimination of penalties due to low PF   | Yes   | Yes  | Yes  |
| Achievement of Unity PF  | No  | No   | Yes  |
| Optimization of the kVA demand of the installation to the installed load in kW | Yes   | Yes  | Yes  |
| Reduction of transformer loading   | Yes   | Yes  | Yes  |
| Reduction of transformer losses  | Yes   | Yes  | Yes  |
| Reduction of circuit breaker rating  | Yes   | Yes  | Yes  |
| Reduction of switchgear ratings and cable sizes down the line                  | Yes   | Partial reduction  | No   |
| Reduction in I <sup>2</sup> R losses   | Yes   | Partial reduction  | No   |
| Chance of leading PF   | No  | Yes  | No   |
| Advantages   | Simple and inexpensive for few number of motors             | Relatively better management of loads                        | Best suited for industries with large and variable loads |
| Disadvantages  | Managing becomes difficult if the number of motors are more | Difficult to manage, if there is load variation in the group | Relatively expensive                                     |

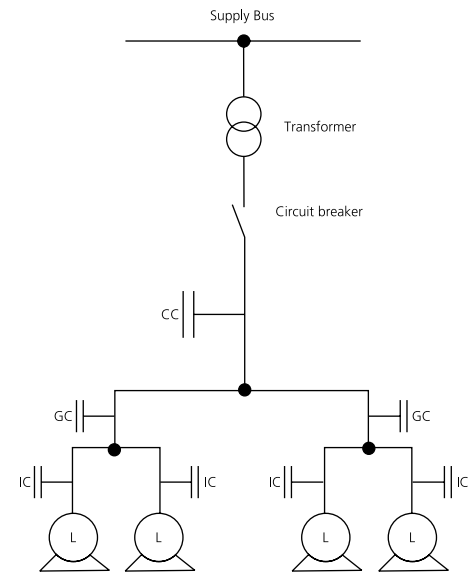

L : Inductive load  
 IC : Individual Compensation  
 GC : Group Compensation  
 CC : Central Compensation

## Step 5: To Achieve Dynamic and Transient Free Unity PF

Conventional switching techniques of capacitors involving electro-mechanical contactors may give rise to transient phenomena. This transient phenomena can interact with impedances present in the installation to create "Surges". This occurrence of surges can cause serious damage to sensitive electronics and automation resulting in either their malfunction or permanent damage. The transient phenomenon is a sudden rise in voltage or current at the point of switching.

In this background, it is important to ensure that all the capacitors installed are switched in a transient free manner so as to ensure reliable performance of the installation.

In such a situation, it is necessary to specify the use of Thyristor switches for transient free switching of Capacitors.

Note: Thyristor switching can also be used for dynamic compensation which is needed if the fluctuation of loads is very high; such as lifts, welding load is very high; fast presses etc.

# Motor Power Factor Compensation

The various methods of power factor correction are direct compensation, group compensation and centralized compensation. Depending upon the size and the rate of change of loads in an industry, any one or combination of the above methods can be employed. Specifically, in case of agricultural pump-sets and some small scale industries with a few motor

loads, the power factor correction can be done by connecting shunt capacitors directly to the motors. This method of compensation is called direct compensation. This is simple and ideal method for reactive power compensation, as this results in rating optimization of all the upstream switchgear and cables, which reduces overall system losses.

Direct motor compensation can be done by two methods:

## Method-1:

As shown in the figure, the capacitor is connected directly to the motor terminals, after the starter. The capacitors would start supplying reactive power, as soon as the motor is switched ON. This method of compensation can be used for motors with

Direct on-line starters. Usually the kVAR rating for a particular motor is given by the respective motor manufacturers, as the kV Ar ratings are motor specific.

| Motor (hp) | 3000 rpm | 1500 rpm | 1000 rpm | 750 rpm | 500 rpm |
|------------|----------|----------|----------|---------|---------|
| 2.5        | 1        | 1        | 1.5      | 2       | 2.5     |
| 5          | 2        | 2        | 2.5      | 3.5     | 4       |
| 7.5        | 2.5      | 3        | 3.5      | 4.5     | 5.5     |
| 10         | 3        | 4        | 4.5      | 5.5     | 6.5     |
| 15         | 4        | 5        | 6        | 7.5     | 9       |
| 20         | 5        | 6        | 7        | 9       | 12      |
| 25         | 6        | 7        | 9        | 10.5    | 14.5    |
| 30         | 7        | 8        | 10       | 12      | 17      |
| 40         | 9        | 10       | 13       | 15      | 21      |
| 50         | 11       | 12.5     | 16       | 18      | 25      |
| 60         | 13       | 14.5     | 18       | 20      | 28      |
| 70         | 15       | 16.5     | 20       | 22      | 31      |
| 80         | 17       | 19       | 22       | 24      | 34      |
| 90         | 19       | 21       | 24       | 26      | 37      |
| 100        | 21       | 23       | 26       | 28      | 40      |
| 110        | 23       | 25       | 28       | 30      | 43      |
| 120        | 25       | 27       | 30       | 32      | 46      |
| 130        | 27       | 29       | 32       | 34      | 49      |
| 140        | 29       | 31       | 34       | 36      | 52      |
| 145        | 30       | 32       | 35       | 37      | 54      |
| 150        | 31       | 33       | 36       | 38      | 55      |
| 155        | 32       | 34       | 37       | 39      | 56      |
| 160        | 33       | 35       | 38       | 40      | 57      |
| 165        | 34       | 36       | 39       | 41      | 59      |
| 170        | 35       | 37       | 40       | 42      | 60      |
| 175        | 36       | 38       | 41       | 43      | 61      |
| 180        | 37       | 39       | 42       | 44      | 62      |
| 185        | 38       | 40       | 43       | 45      | 63      |
| 190        | 38       | 40       | 43       | 45      | 65      |
| 200        | 40       | 42       | 45       | 47      | 67      |
| 250        | 45       | 50       | 55       | 60      | 70      |

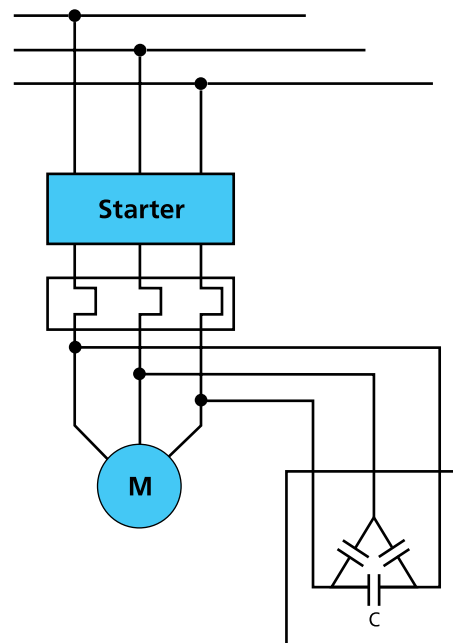

Even though this is the effective method of power factor compensation, there is a limitation in sizing of the capacitors. That is, the maximum kVAR should be decided such that, the rated capacitor current is less than 90% of the motor's no-load current. If this condition is not met, self-excitation may occur, in which the motor acts as a generator. This happens when a motor has enough inertia to keep rotating even after being disconnected from the power system and the capacitor is large enough to supply the reactive power needs of the motor. Self-excitation may result in high voltage at the terminals of the motor and this can damage the contactor and the capacitor. As this method has the limitation in the sizing of maximum kV Ar rating, it is not possible to achieve unity power factor.

## Method-2:

In this method, the capacitor is connected to the motor before the starter and it is switched through a separate capacitor-duty contactor. The capacitors are disconnected as soon as the motor is switched off hence, self-excitation

is avoided. There is no need of any limitations in capacitor sizing and unity power factor can be achieved by this method.

The capacitor size (in kV Ar) can be calculated by the below formula:

$$\text{kVAr} = \text{kW} (\tan \Phi_1 - \tan \Phi_2)$$

where,  $\Phi_1 = \cos^{-1}$  (Initial PF) and  $\Phi_2 = \cos^{-1}$  (Target PF)

The limitations are the manual switching of the capacitors and the extra cost incurred for the contactors. Moreover, when the

number of motors increase in future, managing all at a time would be difficult.

## Motors with Star-Delta Starter

Specifically for motor with star-delta starter, it is recommended to use method-2. If capacitors are directly connected to the terminals of the motor, the life of the capacitor drops drastically because of the voltage spikes that happen during every star to

delta transition. So it is safer to connect the capacitor before the star-delta starter, as shown in the above figure.

## Points to remember

- › The operating power factor varies with respect to the percentage loading of the motors. Hence with the varying load, the fixed capacitors may not be able to maintain the unity power factor continuously.
- › After switching off the capacitor, it is very important to maintain a minimum time delay of 60 seconds, for switching ON the capacitor again. Else, there are more chances of contactor damage because of charged capacitor.
- › If the motor is operated with drives/converters, it is recommended to detune the capacitors by adding series reactors.
- › It is recommended to use capacitor duty contactors for minimizing the inrush current and hence to maximize the life of contactors and the capacitors.

# Transformer Compensation

In order to achieve near unity power factor, all sources of reactive power need to be identified and fully compensated. One such element that consumes reactive power is the transformer. Reactive power is consumed by transformers

through the no load magnetizing current and through the leakage reactance. This section is aimed at helping customers size capacitor banks for transformer compensation.

## Basics

The power factor on the HT side (source side) of a transformer depends upon the following:

- › LT Side (Load side) power factor
- › Real power consumed by transformer
- › Reactive power consumed by transformer

The load side power factor is compensated by employing APFC panels and/or by providing individual compensation to connected loads. Transformer compensation on the other hand needs a different approach. The equivalent circuit of a transformer is as shown below:

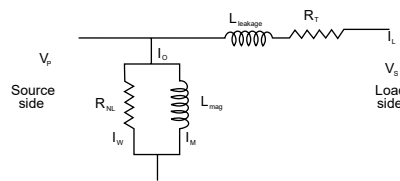

Where:  $V_p$  is the source voltage,  $V_s$  is the load voltage,  $I_0$  is the no load current,  $I_w$  is the no load watt loss current,  $I_M$  is the magnetizing current,  $R_{NL}$  is the no load resistance,  $L_{mag}$  is the magnetizing inductance,  $L_{leakage}$  is the leakage inductance,  $R_r$  is the winding resistance.

As can be seen from the equivalent circuit, the inductive elements, namely  $L_{mag}$  and  $L_{leakage}$  contribute to the VAR consumption of the transformer

## Magnetizing VAR Requirement of A Transformer

The magnetizing VAR consumption is a function of the rated voltage and the magnetizing current of the transformer. The no load current of a transformer varies between 0.5 % and 2.5% of the full load current depending on the design of the transformer and the operating flux level. The magnetizing current is around 80% of the no load current and thus varies between 0.4% and

2%. It is safe to assume a value of 1-1.2% for distribution transformers.

Thus the VAR required to compensate for the magnetizing current of the transformer is around 1- 1.2% of the transformer kVA rating.

## VAR Requirement Due to Leakage Reactance

The VAR requirement due to leakage reactance is a function of the square of the current and the leakage reactance. At full load the voltage drop across the leakage reactance is equal

$$X_{leakage} = \frac{V_2^2}{kVA} \times (\%Z)$$

Where  $V_2$  is the secondary voltage.

$$Q_x = (\%Z) \times (kVA) \times (\%load)^2$$

% loading is assumed to be 50% to 75%. Thus for % Z=5%,  $Q_x$  works out to  $5\% \times (75\%)$  i.e. 3%

Thus the kVAR requirement to compensate for the leakage reactance of the transformer is around 3% of the kVA rating of the transformer.

to the impedance voltage (%Z impedance). The reactive VAR consumption is equal to the product of impedance voltage and load current.

The total kV Ar required to compensate for the reactive power consumed by the transformer is around 4% to 4.25% of the kV A rating of the transformer.

# Reactive Power Compensation of DG Sets

Whenever an industry is drawing power from utility, there are no major complications in managing the reactive power and power factor close to unity can be maintained. However, when diesel generators are operating, some precautions are needed to be taken for managing reactive power. This section briefs the performance of the DG sets at various power factors and thereby shows the optimal manner of power factor compensation of generators with the help of some examples.

Normally DG sets are rated in apparent power (kV A) along with power factor and typical rated power factor is 0.8 lag (considering the power factor of motors, without any capacitors) irrespective of alternator's apparent power. The diesel engine's

mechanical output power (bhp/kW) is designed to match the electrical real power ( $kW = kV \times A \times PF$ ) of the alternator.

For example, consider a generator rated for 1000 kV A and lagging power factor of 0.8. The maximum possible real power (kW) the generator can supply is 800 kW (rated current = 1739 A). Thus, the diesel engine will also be rated to deliver 800 kW equivalent mechanical power to the alternator. The following cases show the operation of the alternator at different power factor.

## Case 1:

Apparent power = 1000 kV A; connected load = 800 kW; power factor = 0.8

Current drawn,  $I_1 = 1000 \times 1000 / (1.732 \times 415 \times 0.8) = 1739 \text{ A}$

- › Here, the generator is operated at the rated name plate values. The load draws maximum rated current from the generator and the generator draws the maximum permissible mechanical power (800 kW) from the diesel engine.

## Case 2:

Apparent power = 1000 kV A; connected load = 800 kW; power factor = 0.6

Current drawn,  $I_2 = 1000 \times 1000 / (1.732 \times 415 \times 0.6) = 2318.9 \text{ A}$

- › In case 2, the connected load is 800 kW (operated at 0.6 PF) which is equal to the maximum mechanical power that the engine can deliver. But the actual current drawn by the load is greater than the rated alternator current. This results in generator overloading. In order to avoid generator overloading, the maximum load (at the same PF) that can be connected to the generator is 600 kW at 0.6 PF.
- › Conversely, if the connected load is 600 kW and if the power factor is at 0.6, the entire generator capacity (1000 kVA) is blocked for this partial load. If the power factor was to be improved to 0.8, then as in case 1 additional 200 kW load could have been connected to the same generator, thereby increasing the capacity and productivity of the industry. Moreover, if 600 kW load is operated at unity power factor, the load current (1391 A) will be reduced by 40%, thereby significant reduction in the copper loss/cable loss. This will result in fuel savings of the engine. This is what is described in case 3 below.

## Case 3:

Apparent power = 1000 kV A; connected load = 800 kW; power factor = 1.0

Current drawn,  $I_3 = 1000 \times 1000 / (1.732 \times 415 \times 1.0) = 1391 \text{ A}$

- › The genset is connected to its full capacity of 800 kW operating at unity power factor. Unlike case 1, the load draws 20% less current at UPF (1391 A). This in turn results in significant reduction in copper loss/cable loss and thereby saving some fuel.
- › Here, at UPF, even though the generator can support a load of 1000 kW, the diesel engine is rated to deliver a maximum mechanical power of 800 kW.
- › Even though the current drawn is less than the rated current (1739 A), the genset is delivering its maximum real power (800 kW).
- › Hence at UPF, utmost care should be taken such that the total connected electrical load must not exceed 800 kW. otherwise the diesel engine will be overloaded.

## Summary

- › Close to unity power factor shall be maintained for the loads connected to the DG sets by using capacitors. This will result in the reduction of copper loss and hence savings in fuel.

# Standard Automatic Power Factor Correction Panels

Modern power networks cater to a wide variety of electrical and power electronics loads, which create a varying power demand on the supply system. In case of such varying loads, the power factor also varies as a function of the load requirements.

It therefore becomes practically difficult to maintain consistent power factor by the use of fixed compensation i.e. fixed capacitors which shall need to be manually switched to suit the variations of the load. This will lead to situations where the installation can have a low power factor leading to higher demand charges and levy of power factor penalties.

In addition to not being able to achieve the desired power factor it is also possible that the use of fixed compensation can also

result in leading power factor under certain load conditions. This is also unhealthy for the installation as it can result in over voltages, saturation of transformers, mal-operation of diesel generating sets, penalties by electricity supply authorities etc.

Consequently the use of fixed compensation has limitations in this context. It is therefore necessary to automatically vary, without manual intervention, the compensation to suit the load requirements. This is achieved by using an Automatic Power Factor Correction (APFC) system which can ensure consistently high power factor without any manual intervention. In addition, the occurrence of leading power factor will be prevented.

## APFC Panels are Fully Automatic in Operation and can be used to Achieve:

- › Consistently high power factor under fluctuating load conditions
- › Elimination of low power factor penalty levied by electrical supply authorities
- › Reduced kV A demand charges
- › Lower energy consumption in the installation by reducing losses
- › Preventive leading power factor in an installation

## Basic Operation

- › To continuously sense and monitor the load condition by the use of external CT (whose output is fed to the control relay)
- › To automatically switch ON and OFF relevant capacitor steps on to ensure consistent power factor
- › To ensure easy user interface for enabling reliable system operations
- › To protect against any electrical faults in a manner that will ensure safe isolation of the power factor correction equipment

## Salient Features and Advantages

- › Pre-selected optimal number of steps and step sizes, for better step resolution and hunt free capacitors switching
- › Ideal switchgear selection for reliable short circuit protection, without nuisance tripping
- › Right capacitor-reactor combination selection to prevent harmonic amplification and resonance
- › Option of capacitor duty contactor or thyristor switch for transient free switching
- › Panels with better electrical, mechanical and thermal design for longer life of capacitors and other components
- › Panels are with advanced microcontroller based APFC relay that offers reliable switching operation with four quadrant sensing

# Capacitor Step Size Selection Guidelines in Apfc Panels

Major part in the design of APFC panels is the selection of step size of capacitor banks and number of steps. The right selection of step size and number of steps plays a significant role in the

performance as well as cost of the APFC panel. This section focuses on the need and ways of good step size (maximum and minimum sizes) selection and number of steps.

## 1. Maximum Step Size Selection

The maximum capacitor rating in an APFC panel depends upon the following:

1. Maximum amount of load variation that happens in the industry at a time: Large load variations demand bigger capacitor steps so that target power factor is achieved in short time, by less number of switching operations.
2. Current and voltage transient withstand capabilities of the system:
  - » Current transients: Switching of big capacitors (usually above 100 kV Ar) introduces large magnitude of inrush current (current transients) for a small duration. This results in high thermal and electrical stress on capacitors, short circuit protection devices and mainly, the switching device. This may lead to their nuisance tripping and premature failures
  - » Voltage transients: Switching of big capacitors may cause transient over voltages, which might result in failure of sensitive electronic devices

Thus, the maximum size of the capacitor step is a trade-off between the points i and ii. Practically acceptable maximum possible rating in any APFC panel shall be 100 kV Ar. If this 100 kV Ar rating capacitor is switched using power contactor, the peak inrush current may reach as high as 75 kA. Hence, the capacitors should be switched using either capacitor duty contactors or thyristor switching module.

However, 100 kV AR Capacitor duty contactor can be used for 100 kV AR bank but in case of a thyristor switched panel, thyristor switching module for 100 kV Ar rating is not readily available. Hence, the best way to switch a 100 kV Ar bank is by connecting two 50 kV Ar TSM in parallel, each with a separate physical 50 kV Ar capacitor banks. The control supply to both the 50 kVAr TSM shall be common (one relay output of the controller), so that both of the devices are triggered at the same time. To achieve this, the common output of the APFC relay should be programmed as 100 kV Ar. Hence, physically they are two separate 50 kV Ar banks, whereas electrically they behave as a single 100 kVAr bank.

A sample connection diagram for switching a step of 100 kV Ar with 7% Detuned reactor and two TSMs is shown as under:

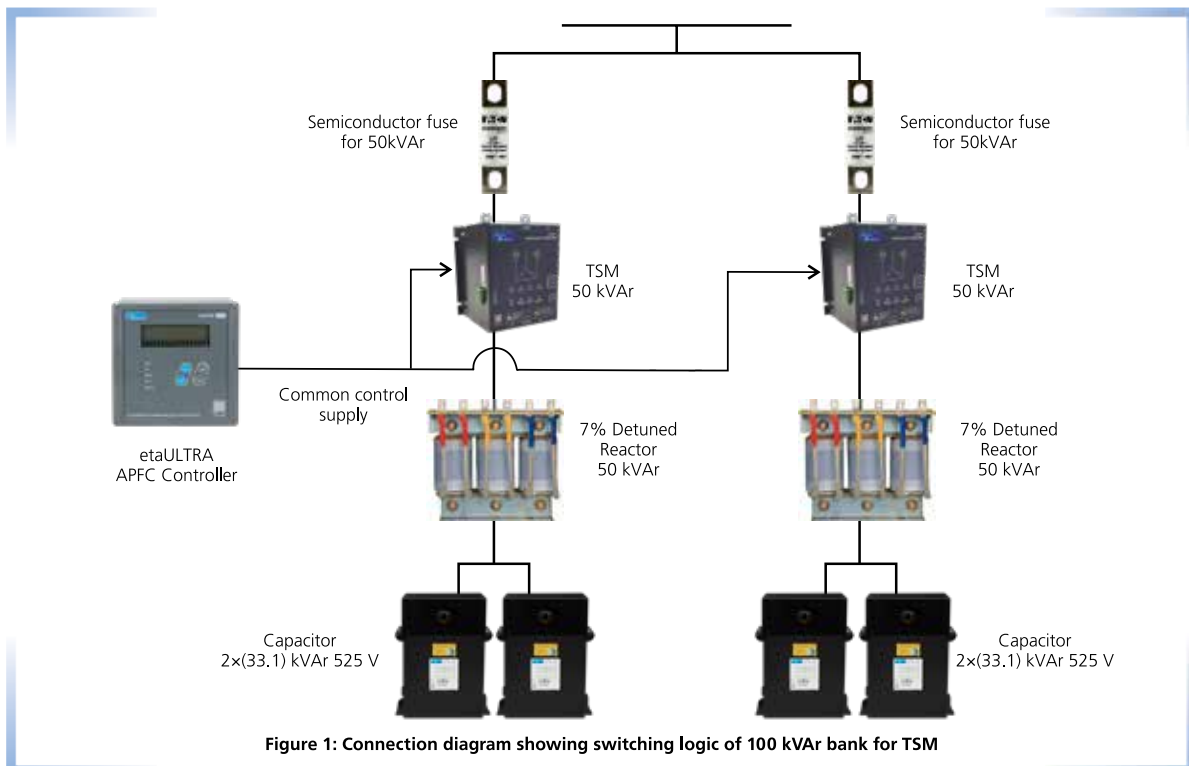

Figure 1: Connection diagram showing switching logic of 100 kVAr bank for TSM

## 2. Minimum Step Size Selection

The minimum capacitor rating depends on how precise the power factor needs to be maintained. This minimum kV Ar rating depends upon the minimum current sensitivity (typically around 2.5%) of the APFC controller. However the change in PF due to these minimum selected kVAr rating would be usually in the 3rd or 4th decimal places (depending on panel size or kVAr requirement), whereas the electricity board is concerned only with the first two digits of PF (like 0.99).

Typically many industries want the desired target PF to be unity (exactly 1 .00), in order to get incentives from some EBs. But practically, the optimum target PF has to be 0.96 to 0.99.

These are healthy levels of power factor as it will have safety margin that avoids the leading power factor as well as any dangerous harmonic amplification (due to more capacitance in the system).

Hence, as a rule of thumb, the minimum kV Ar rating in an APFC panel can be chosen to be 5-10% of overall rating of APFC panel. For smaller rating APFC panels (up to 100 kVAr), the smallest step can be 5 kVAr and for bigger rating APFC panels (above 600 kV Ar and upto 1000 kVAr) the minimum rating can be 25 kV Ar.

## 3. Number of Steps/ Branches in APFC Panels

Once the minimum and maximum kV Ar rating of the APFC panel is selected, the number of branches can be decided upon based of the following:

i. Technology of APFC controllers: Latest APFC controllers like etaULTRA Series employ self-optimized intelligent switching where the controller calculates the exact kVAr requirement and switches ON/ OFF the appropriate capacitors irrespective of the capacitors already in circuit. Traditional controllers employing linear or circular switching require more number

of smaller steps (like 1 :2:2:... ) for effective power factor correction. Whereas the latest controllers like etaULTRA can have a mix of large and small steps reducing the number of steps in capacitor bank as well as the cost of associated switchgear.

ii. Size & cost of APFC panel: More the number of steps more will be the cost of APFC panel, due to more number of switchgear, bigger size of panel and others.

### An APFC panel should have:

- Maximum number of electrical steps (combination of physical steps) to ensure more accurate and flexible power factor correction
- Minimum number of physical steps to reduce the size and cost of the panel

Let us consider a few examples of step size selection in APFC panels.

### I. 100 kVAr APFC panel

|                         | Case A                           | Case B                         |
|-------------------------|----------------------------------|--------------------------------|
| Step configuration      | 10 + 10 + 10 + 10 + ... 10 times | 50 + 25 + 15 + 5 + 5           |
| Step resolution         | 10 kVAr                          | 5 kVAr                         |
| Electrical Steps        | 10, 20, 30, 40, 50, ... 100      | 5, 10, 15, 20, 25, 30, ... 100 |
| Physical Steps          | 10                               | 5                              |
| No. of Electrical Steps | 10                               | 20                             |

In case B, 20 electrical steps are possible with only 5 physical steps; whereas in case A, 10 physical steps are required to achieve 10 electrical steps.

### II. 300 kVAr APFC panel

|                         | Case A                             | Case B                             |
|-------------------------|------------------------------------|------------------------------------|
| Configuration           | 25 + 25 + 25 + 25 + ... 12 times   | 1x100 + 2x50 + 4x25                |
| Step resolution         | 25 kVAr                            | 25 KVAR                            |
| Electrical Steps        | 25, 50, 75, 100, 125, ... 275, 300 | 25, 50, 75, 100, 125, ... 275, 300 |
| Physical Steps          | 12                                 | 7                                  |
| No. of Electrical Steps | 12                                 | 12                                 |

Case B is better as same electrical steps are achieved with just 7 physical steps.

### III. 600 kVAr APFC panel

|                         | Case A                           | Case B                          |
|-------------------------|----------------------------------|---------------------------------|
| Configuration           | 50 + 50 + 50 + 50 + ... 12 times | 3x100 + 5x50 + 2x25             |
| Step resolution         | 50 kVAr                          | 25 KVAR                         |
| Electrical Steps        | 50, 100, 150, 200, 250, ... 600  | 25, 50, 75, 100, 125, ... , 600 |
| Physical Steps          | 12                               | 10                              |
| No. of Electrical Steps | 12                               | 24                              |

In Case B, 24 electrical steps are possible with only 10 physical steps; whereas in Case A, 12 physical steps are required to achieve 12 electrical steps.

## Summary

- › APFC panels with more number of steps (more than 12) does not always mean better step resolution
  - › With the latest APFC controller technology, fewer steps are sufficient to achieve better step resolution and control of power factor
  - › Hence, usually a combination of large, small and very small ratings is used in steps of capacitor banks, as given below:
1. Large rating capacitors (100 kV Ar maximum) are required to PF compensation of base load and coarse power factor compensation
  2. Medium rating capacitors are meant for variable part of the reactive power compensation.
  3. Small rating capacitors (usually 5 to 10% of total kV Ar or 25 kV Ar for panels above 500 kV Ar) are meant for fine tuning of the power factor.

Considering the above points, following table suggests optimum number of steps and step sizes from 35 kVAr to 1000

kV Ar. Beyond 1000 kV Ar, it is always better to split the APFC panels and install them at different PCC/MCC levels.

| Panel Rating (kVAr) | Physical Step Size (kVAr) | No. of Physical Steps | Electrical / Logical Steps                         | No. of Electrical Steps |
|---------------------|---------------------------|-----------------------|--|-------------------------|
| 35                  | 20 + 10 + 2 x 2 + 1       | 5                     | 1, 2, 3, 4, 5, 10.....33, 34, 35                   | 23                      |
| 50                  | 25 + 15 + 5 + 3 + 2       | 5                     | 2, 3, 5, 7, 8, 10.....45, 47, 48, 50               | 26                      |
| 75                  | 2 x 25 + 15 + 5 + 3 + 2   | 6                     | 2, 3, 5, 7, 8, 10.....68, 70, 72, 73, 75           | 39                      |
| 100                 | 50 + 25 + 15 + 4 + 2 x 3  | 6                     | 3, 4, 6, 7, 10, 15.....90, 93, 94, 96, 97, 100     | 44                      |
| 125                 | 50 + 2 x 25 + 2 x 10 + 5  | 6                     | 5, 10, 15, 20, 25, 30, 35, 40, 45, 50.....120, 125 | 25                      |
| 150                 | 50 + 3 x 25 + 15 + 10     | 6                     | 10, 15, 25, 35, 40, 50, 60, 65, 75.....140, 150    | 18                      |
| 175                 | 2 x 50 + 2 x 25 + 15 + 10 | 6                     | 10, 15, 25, 35, 40, 50, 60, 65, 75.....165, 175    | 21                      |
| 200                 | 3 x 50 + 25 + 15 + 10     | 6                     | 10, 15, 25, 35, 40, 50, 60, 65, 75.....190, 200    | 24                      |
| 225                 | 3 x 50 + 2 x 25 + 15 + 10 | 7                     | 10, 15, 25, 35, 40, 50, 60, 65, 75.....215, 225    | 27                      |
| 250                 | 3 x 50 + 4 x 25           | 7                     | 25, 50, 75, 100, 125, 150, 175, 200, 225, 250      | 10                      |
| 275                 | 4 x 50 + 3 x 25           | 7                     | 25, 50, 75, 100, 125, 150, 175.....250, 275        | 11                      |
| 300                 | 100 + 2 x 50 + 4 x 25     | 7                     | 25, 50, 75, 100, 125, 150, 175....275, 300         | 12                      |
| 350                 | 100 + 3x50 + 4 x 25       | 8                     | 25, 50, 75, 100, 125, 150, 175....325, 350         | 14                      |
| 400                 | 2 x 100 + 2 x 50 + 4 x 25 | 8                     | 25, 50, 75, 100, 125, 150, 175....375, 400         | 16                      |
| 450                 | 2 x 100 + 3 x 50 + 4 x 25 | 9                     | 25, 50, 75, 100, 125, 150, 175....425, 450         | 18                      |
| 500                 | 2 x 100 + 5 x 50 + 2 x 25 | 9                     | 25, 50, 75, 100, 125, 150, 175....475, 500         | 20                      |
| 550                 | 3 x 100 + 3 x 50 + 4 x 25 | 10                    | 25, 50, 75, 100, 125, 150, 175....500, 550         | 22                      |
| 600                 | 3 x 100 + 5 x 50 + 2 x 25 | 10                    | 25, 50, 75, 100, 125, 150, 175....575, 600         | 24                      |
| 650                 | 4 x 100 + 3 x 50 + 4 x 25 | 11                    | 25, 50, 75, 100, 125, 150, 175....625, 650         | 26                      |
| 700                 | 4 x 100 + 5 x 50 + 2 x 25 | 11                    | 25, 50, 75, 100, 125, 150, 175....675, 700         | 28                      |
| 750                 | 5 x 100 + 3 x 50 + 4 x 25 | 12                    | 25, 50, 75, 100, 125, 150, 175....725, 750         | 30                      |
| 800                 | 5 x 100 + 5 x 50 + 2 x 25 | 12                    | 25, 50, 75, 100, 125, 150, 175....775, 800         | 32                      |
| 850                 | 6 x 100 + 3 x 50 + 4 x 25 | 13                    | 25, 50, 75, 100, 125, 150, 175....825, 850         | 34                      |
| 900                 | 6 x 100 + 5 x 50 + 2 x 25 | 13                    | 25, 50, 75, 100, 125, 150, 175....875, 900         | 36                      |
| 950                 | 7 x 100 + 3 x 50 + 4 x 25 | 14                    | 25, 50, 75, 100, 125, 150, 175....925, 950         | 38                      |
| 1000                | 7 x 100 + 5 x 50 + 2 x 25 | 14                    | 25, 50, 75, 100, 125, 150, 175....975, 1000        | 40                      |

The above table is for illustration only, which may be applicable for majority of industries. For accurate compensation, step ratings shall

be decided after studying the load profile of the industry. We also provide step ratings from 1 to 4 kVAr for better resolution.

### Disclaimer

For accurate compensation, the load profile of the industry needs to be studied. This gives an indication of the size of peak loads, base loads, possible harmonics, power factor and thus, helps determine

step sizes based on load variations. In some cases, the load requirements can also be established from equipment lists.

# Fuse Selection for APFC Panels

For any APFC panel, fuses are required for faster short circuit protection and overload protection of capacitors. Fuse selection for capacitive load is critical because of heavy inrush current, high overload capacity and continuous full load. These inherent traits of a capacitor, complicates the selection process. Hence the selection should be such that even during these permissible abnormalities, the fuse should not blow.

Normally, the maximum permissible current in a capacitor branch is 2 times the rated current. This factor is comprised of the following:

- › Harmonics overload and overvoltage-30%
- › Capacitance tolerance -10%
- › Frequency variation - 2 %
- › Fuse deration factor- 35%

The following table\*\* shows the selection of Fuses and Capacitor switching contactors for an APFC panel:

| kVAr | Rated Current* (A) | Derating Factor | Allowed O/C for Capacitor (A) | Recommended Contactor* | Fuse Rating (A) |
|------|--------------------|-----------------|-------------------------------|------------------------|-----------------|
| 10   | 13.12              | 2               | 26.24                         | MO C10                 | 32              |
| 15   | 19.68              | 2               | 39.36                         | MO C15                 | 40              |
| 20   | 26.24              | 2               | 52.48                         | MO C20                 | 63              |
| 25   | 32.80              | 2               | 65.60                         | MO C25                 | 80              |
| 50   | 65.61              | 2               | 131.22                        | MO C50                 | 160             |

\* Selection principle is same for other family of fuses

\*\*The table is valid only for LK switchgear and capacitors at 440 V

The rated current of a capacitor can be calculated as.

$$\frac{(1000 \times \text{kVAr})}{(\sqrt{3} \times V)}$$

For any capacitor bank, permissible overload is 2 times rated capacitor current. Hence, fuses should be rated to carry continuous overcurrent as given in the above table. In case Thyristor Switching Modules are used instead of capacitor duty contactors, it is highly recommended to use High Speed Fuses (semiconductor fuse).

The fuse used for branch protection must be capable of carrying this current continuously. Hence the fuse should be sufficiently rated so as to avoid the deterioration of the fuse element. Further the fuse should not blow during switching of the capacitors because of the inrush current (more than 100 times the capacitor rated current). In order to prevent nuisance operation of fuse, its time-current characteristic should cover the peak inrush current of the capacitor. Hence for the optimal selection of fuses, the inrush current must be limited by using either capacitor duty contactor or inrush current limiting reactor.

Above selection chart is valid only if fuses are used along with capacitor duty contactor. Please consider the above table purely as a guideline for selection. Actual selection needs to be done based on considerations of connected load

# MCCB Selection for APFC Panels

For any APFC panel, MCCBs are required for short circuit protection, overload protection and for isolation of capacitors. MCCB selection for capacitive load is tricky because of heavy inrush current, high overload capacity and continuous full load. These inherent traits of a capacitor, complicates the selection process. The selection should be such that the MCCB should not nuisance trip during inrush current and should withstand continuous flow of overload current.

Whenever we use MCCB in an APFC panel, proper measures need to be taken against the ill effects of the inrush current. Normally the inrush current (more than 100 times the capacitor rated current) will remain for a few microseconds and will not be sensed by the MCCB. However the contacts of MCCB may repel and bounce because of the current limiting feature, causing micro-arcs between the contacts of MCCB. This multiple bounce can result in premature failure of MCCB contacts. In order to reduce the magnitude of the peak inrush current, MCCBs must be used along with capacitor duty contactors or inrush current limiting reactors.

The maximum permissible current in a capacitor branch is 1.46 times the rated current. This factor is comprised of the following:

- › Harmonics overload and over voltage - 30%
- › Capacitance tolerance - 10%
- › Frequency variation - 2 %

The branch MCCB must be capable of carrying this current continuously.

The following table\*\* shows the selection of MCCBs and Capacitor switching contactors for an APFC panel:

| kVAr | Rated Current*A | Derating Factor | Permissible Capacitor O/L (A) | Recommended Contactor+ | MCCB*        | Thermal Setting (A) |                                       | Magnetic Setting (6 to 10*IR) |
|------|-----------------|-----------------|-------------------------------|------------------------|--------------|---------------------|---------------------------------------|-------------------------------|
|      |                 |                 |                               |                        |              | I <sub>N</sub>      | I <sub>R</sub> (100% I <sub>N</sub> ) |                               |
| 10   | 13.12           | 1.46            | 19.16                         | MO C10                 | DU / DN / DZ | 19                  | 19                                    | 171                           |
| 15   | 19.68           | 1.46            | 28.74                         | MO C15                 | DU / DN / DZ | 29                  | 29                                    | 261                           |
| 20   | 26.24           | 1.46            | 38.32                         | MO C20                 | DU / DN / DZ | 38                  | 38                                    | 342                           |
| 25   | 32.80           | 1.46            | 47.90                         | MO C25                 | DU / DN / DZ | 48                  | 48                                    | 432                           |
| 30   | 39.37           | 1.46            | 57.47                         | MO C30                 | DU / DN / DZ | 58                  | 58                                    | 513                           |
| 50   | 65.61           | 1.46            | 95.79                         | MO C50                 | DU / DN / DZ | 96                  | 96                                    | 864                           |

\* Selection principle is same for other family of fuses

\*\*The table is valid only for LK switchgear and capacitors at 440 V

The rated current of a capacitor can be calculated as.

$$\frac{(1000 \times \text{kVAr})}{(\sqrt{3} \times V)}$$

For any capacitor bank, permissible overload is 1.46 times rated capacitor current. Hence, MCCB should be rated to carry continuous over current as given in the above table.

Above selection chart is valid only if MCCB is used along with capacitor duty contactor Please consider the above table purely as a guideline for selection. Actual selection needs to be done based on considerations of connected load and the electrical network properties.

# Cable Selection for Capacitors

Switchgear and cable selection for capacitor application is quite challenging. The reason is the capacitive networks are more prone to over-current, high peak inrush current and continuous flow of full load current. Usually the capacitors are designed to withstand and operate normally, even during the above said abnormalities, for a finite amount of time. Hence, the switchgear and cables in the capacitor network should be rated accordingly, so as to withstand & operate normally during these abnormalities.

The capacitors draw over-current because of the harmonics, capacitance tolerances, voltage variation and frequency variation. The permitted over-current is up to 146% of the rated current, which comprises the following:

The capacitors draw over-current because of the harmonics, capacitance tolerances, voltage variation and frequency variation. The permitted over-current is up to 146% of the rated current, which comprises the following:

- › Harmonics overload and over voltage- 30%
- › Capacitance tolerance-10%
- › Frequency variation - 2 %

Accordingly, the cables should also be de rated, to continuously withstand permitted over-current. The de rated cable will also help in withstanding the electrical and thermal stresses that occur during every switching cycle because of high inrush current.

Following is the recommended cable selection chart:

| Capacitor Rating (kVAr) | Current at the Rated Voltage (in A) |        | Derated Current at the Rated Voltage (in A) |        | Minimum Recommended Copper Cable Size** (sq.mm) |
|-------------------------|-------------------------------------|--------|---|--------|---|
|                         | 440 V                               | 415 V  | 440 V                                       | 415 V  |   |
| 1                       | 1.31                                | 1.39   | 1.92  | 2.03   | 0.5   |
| 2                       | 2.62                                | 2.78   | 3.83  | 4.06   | 0.5   |
| 3                       | 3.94                                | 4.17   | 5.75  | 6.09   | 0.75  |
| 4                       | 5.25                                | 5.56   | 7.66  | 8.12   | 1   |
| 5                       | 6.56                                | 6.96   | 9.58  | 10.16  | 1   |
| 6                       | 7.87                                | 8.35   | 11.49                                       | 12.19  | 2.5   |
| 7.5                     | 9.84                                | 10.43  | 14.37                                       | 15.23  | 2.5   |
| 8.3                     | 10.89                               | 11.55  | 15.90                                       | 16.86  | 2.5   |
| 10                      | 13.12                               | 13.91  | 19.16                                       | 20.31  | 4   |
| 12.5                    | 16.40                               | 17.39  | 23.95                                       | 25.39  | 4   |
| 15                      | 19.68                               | 20.87  | 28.74                                       | 30.47  | 6   |
| 20                      | 26.24                               | 27.82  | 38.32                                       | 40.62  | 10  |
| 25                      | 32.80                               | 34.78  | 47.90                                       | 50.78  | 16*   |
| 50                      | 65.61                               | 69.56  | 95.79                                       | 101.56 | 35  |
| 75                      | 98.41                               | 104.34 | 143.69                                      | 152.34 | 70  |
| 100                     | 131.22                              | 139.12 | 191.58                                      | 203.12 | 95  |

\*\* Cross section values mentioned above are guidelines that are valid for operation under normal conditions and at ambient temperature of 40°C.

\* Use spreader while using 16 sq.mm cable

Busbar selection in APFC panels can be done with the standard calculations for short circuit withstand capability and It is recommended to use capacitor duty contactors to reduce the magnitude of peak inrush current. This will reduce the thermal and electrical stress in the capacitors, cables and switchgear,

which happens during each switching cycle. This also prevents the premature failure of capacitors and nuisance tripping of short circuit protection device. The temperature rise (current density). The only assumption is that the rated current should be considered as 146% of the total capacitor rated current.

# Thermal Design of APFC Panels

The life of the power capacitors and other equipment in APFC panels depend very much on the operating temperature. In panels with detuned harmonic filter reactors and thyristor switches, the chances of elevated temperature are high, as these equipments generate relatively more heat.

Hence in order to maximise the life of the capacitors and other important equipments in the APFC panel, the temperature must not be allowed to increase beyond certain limit. This section briefs some guidelines about the thermal design of APFC panels and thereby managing the heat effectively.

For any panel, the temperature rise can be reduced by the following three ways:

- › Operating at lower ambient temperature
- › Using devices with lower power loss
- › Dissipating the excess heat, so that temperature rise is controlled

If the temperature rise ( $T_1 - T_a$ ) is within the acceptable limits, natural cooling would be sufficient; else forced cooling method should be employed for dissipating excessive heat.

There is minimal control over the first two conditions. But the third condition completely depends upon the design of the panel. By offering effective cooling methods, the excess heat generated by the equipments can be dissipated.

There is minimal control over the first two conditions. But the third condition completely depends upon the design of the panel. By offering effective cooling methods, the excess heat generated by the equipments can be dissipated.

Selection of the cooling methods can be decided based on the internal temperature rise inside the panel. The maximum internal temperature can be calculated using the following formula:

$$\text{Internal Temperature } (T_1) = \frac{P_d}{k \times S} + T_a$$

Where,  $P_d$  = Total power dissipated in the panel (in watts)

$k$  = constant defined by the material used to manufacture the enclosure

For painted sheet-steel enclosure,  $k = 5.5 \text{ W/m}^2 \text{ }^\circ\text{C}$

$S$  = effective surface area of the panel (in  $\text{m}^2$ )

$T_a$  = Ambient temperature (in  $^\circ\text{C}$ )

Selection of the cooling methods can be decided based on the internal temperature rise inside the panel. The maximum internal temperature can be calculated using the following formula:

## 1. Natural Cooling

In most of PCCs and MCCs, the temperature rise remains under desirable limits with natural circulation of air (through natural convection and radiation). The air circulation happens through some slots in the enclosure, called the louvers. When temperature rises inside the panel, the pressure of the air increases and the density reduces.

Hence the hot air tends to move upwards. The hot air would go out through the louvers provided at the top side of the panel. Fresh cold air would enter the panel through the louvers provided at the bottom. This is represented in Figure 1.

Figure 2 represents the common usage of extra louvers in-between the top and bottom louvers.

The common misconception behind this is that, extra louver would increase the volume of air flow. Practically, this does not happen because the volume of the panel is fixed.

This results in the reduced air flow at the bottom section of the panel, as some air enters through the middle louvers. Hence, the temperature of the lower section of the panel will be higher than the upper section.

It is recommended to follow the panel design as per the Figure 1.

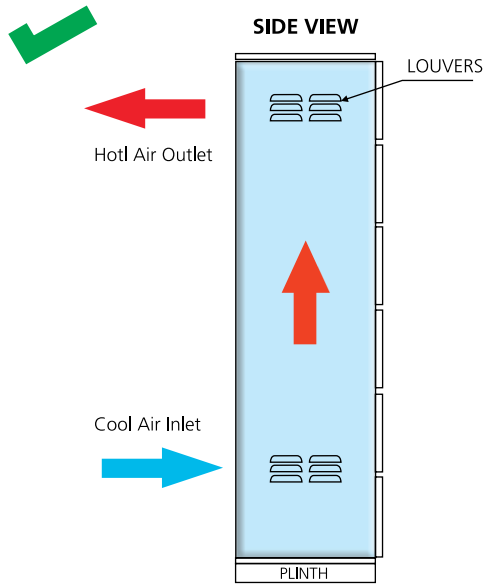

Figure 1

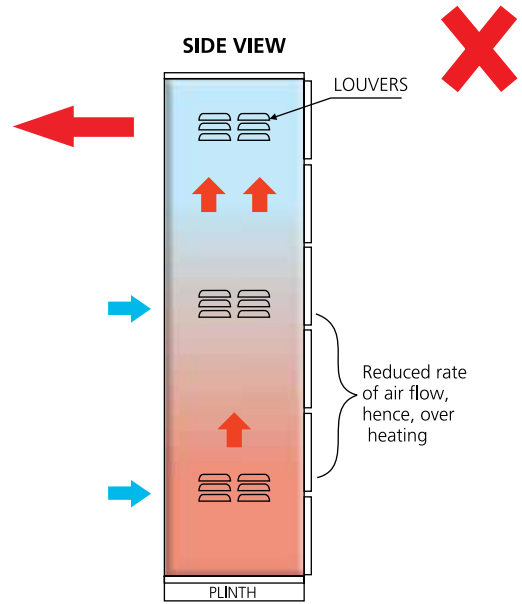

Figure 2

## 2. Forced Cooling

In most of the APFC panels and in some MCC and PCC panels, the above method would not offer sufficient cooling. In order to maintain the desired temperature levels (ambient temperature + allowed temperature rise), forced cooling methods (using fans at the top) should be employed, which would increase the rate of air flow.

In Figure 3 the cold air enters through the bottom louvers, flows through all the equipments and they are forced out of the panel through fans. Hence, temperature rise in the panel is kept under check and there are no hot spots/sections.

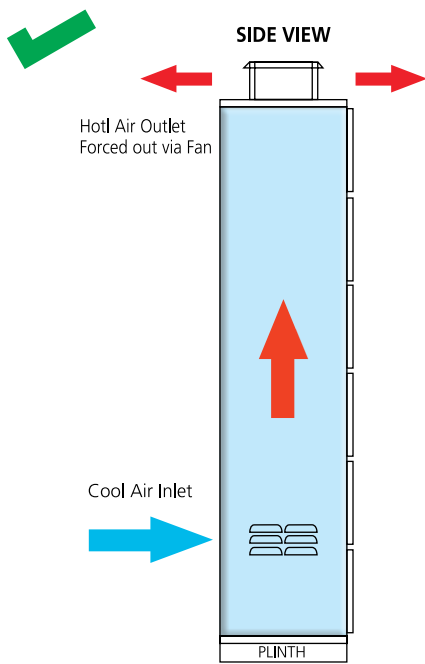

Figure 3

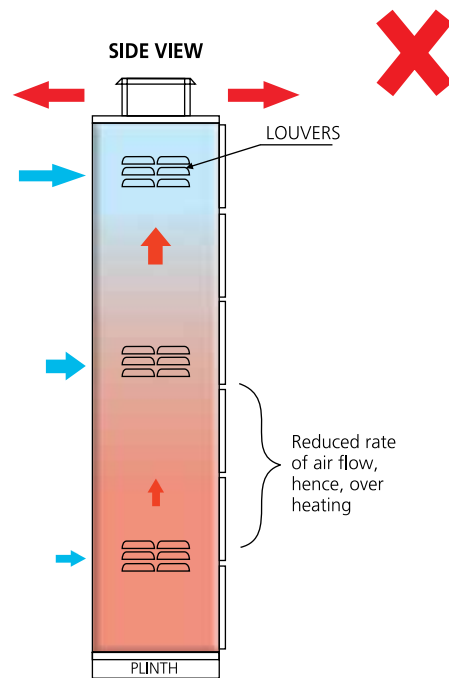

Figure 4

In Figure 4 provision of additional louvers, actually disturbs the uniformity of the flow. Major chunk of cold air would enter through the top louver and result in "short cycling". So the bottom section of the panel would see higher temperature rise.

## 2.1 Fan Selection for Forced Cooling

Fan selection is based on the rate of air flow, which is measured in m<sup>3</sup>/h or Cubic Feet per Minute (CFM), where 1 CFM = 1.7 x 1 m<sup>3</sup>/h. Following is the formula to calculate air flow rate:

$$Q = C_x \frac{P_d [k \times S (T_d - T_a)]}{(T_d - T_a)}$$

Where, Q = Air flow rate (in m<sup>3</sup> /h)

C = Coefficient related to the altitude above the sea level







| Altitude (in Meters) | C   |
|----------------------|-----|
| 0 to 100             | 3.1 |
| 101 to 250           | 3.2 |
| 251 to 500           | 3.3 |
| 501 to 750           | 3.4 |
| 751 to 1000          | 3.5 |

P<sub>d</sub> = total power loss (watts) inside the panel, by summing up the power loss of individual devices like capacitors, reactors, thyristor switches, contactors, bus bars, joints and so on.

k = constant defined by the material used to manufacture the enclosure.

For painted sheet-steel enclosure, k = 5.5 W/m<sup>2</sup>°C

S = Open surface area of the panel (in sq. m) can be calculated using one of the below formulas:

| Position of the Enclosure   | Formula for Calculating S (in sq. m) as per IEC 890 |
|---|---|
|  accessible on all sides  | S = 1.8 x H x (W + D) + 1.4 x W x D                 |
|  placed against a wall   | S = 1.4 x W x (H + D) + 1.8 x D x H                 |
|  end of a row of enclosures  | S = 1.4 x D x (H + W) + 1.8 x W x H                 |
|  end of a row of enclosures with back against the wall                           | S = 1.4 x H x (W + D) + 1.4 x W x D                 |
|  intermediate in a row of enclosures   | S = 1.8 x W x H + 1.4 x W x D + D x H               |
|  intermediate in a row of enclosures with the back against the wall              | S = 1.4 x W x (H + D) + D x H                       |
|  intermediate in a row of enclosures back against the wall with top part covered | S = 1.4 x W x H + 0.7 x W x D + D x H               |

T<sub>d</sub> = Desired Maximum temperature inside the enclosure

T<sub>a</sub> = Ambient temperature

This is a simple method of thermal management and fan selection, which is suitable for majority of the panels. At the same time, some other aspects like position of mounting various equipments in the APFC panel should be taken care. Some of them are as follows:

- › Capacitors should be kept below the reactors, which are the major heat sources. This is because the elevated temperature would reduce the life of the capacitors.
- › The reactors should be mounted in the zigzag position (as shown in the below figure), in order to ensure better heat flow. If the reactors are kept one above other, the bottom most reactors would heat up the other reactors that are mounted above them.

- › Thyristor switching modules should be mounted vertically (position of heat sink should be parallel to the air flow direction) and in zigzag positions. The TSM panel should be non-compartmentalized design for better heat dissipation.
- › Reactors & capacitors should be mounted over channels to allow the free flow of air. Flat base plates are not recommended.
- › The panel should not be compartmentalized. Compartmentalised design would lead to heat accumulation in the panel.
- › For Reactors and TSM, a clearance of 100 mm should be maintained in all directions.

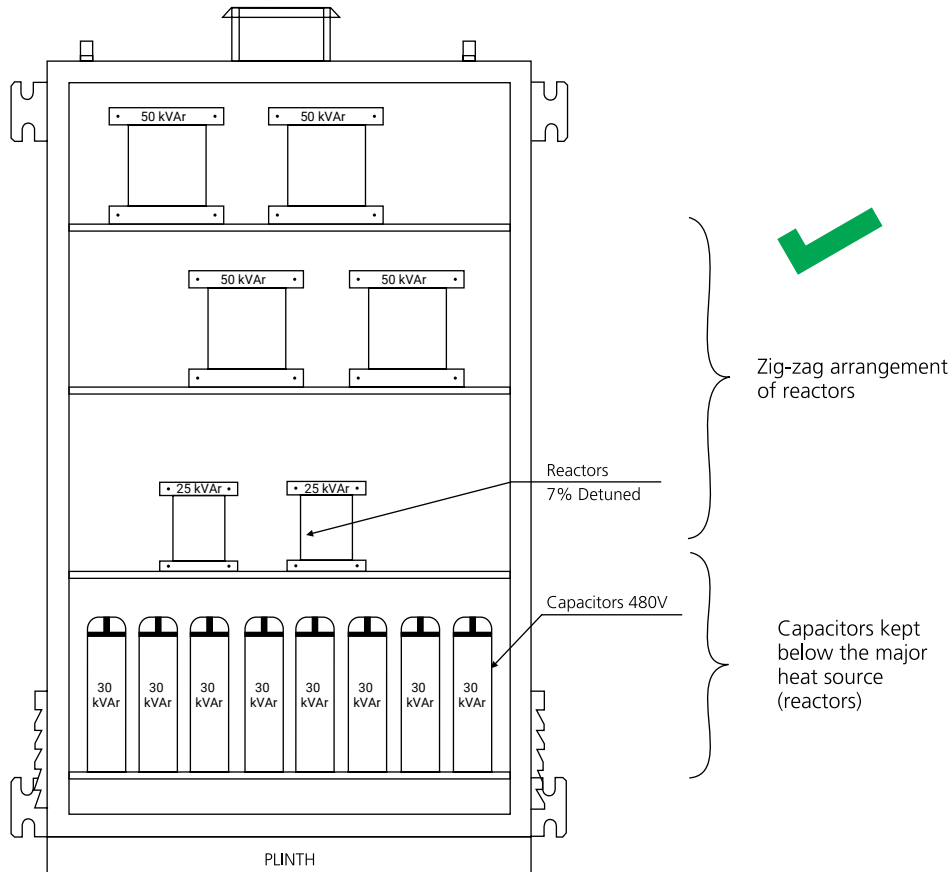

Hence, in APFC panels, a proper thermal design would pave way for maximising the life of important equipments like

# Electrical Standard Products (ESP) Offices

## HEAD OFFICE

Lauritz Knudsen Electrical & Automation, A/600, Shil-Mahape Road, TTC Industrial Area, MIDC Thane, Navi Mumbai, 400 710, Maharashtra.  
Tel: 022-6722 6300 | Fax: 022-6705 1112 | e-mail: CIC@LK-EA.com

## BRANCH OFFICES

Lauritz Knudsen Electrical & Automation  
C-201, The First Commercial Complex,  
B/S Keshavbaug Party Plot, Vastrapur,  
**Ahmedabad - 380 015**  
Phone No: 022-6932 7800  
e-mail: CIC@LK-EA.com

Lauritz Knudsen Electrical & Automation  
Shri Daneshwari, 1st Floor,  
Plot No. 17, 2nd Cross, Near Old Income  
Tax Office Road, Vidyanagar,  
**Hubballi - 580 021**  
Phone No: 022-6932 7800  
e-mail: CIC@LK-EA.com

Lauritz Knudsen Electrical & Automation  
No.10, Fortuna Towers, 2nd Floor,  
Rana Pratap Marg, Near NBRI,  
**Lucknow - 226 001**  
Phone No: 022-6932 7800  
e-mail: CIC@LK-EA.com

Lauritz Knudsen Electrical & Automation  
A06/A07, Second Floor,  
Grand Chandra Complex, Frazer Road  
**Ratna - 800 001**  
Phone No: 022-6932 7800  
e-mail: CIC@LK-EA.com

Lauritz Knudsen Electrical & Automation  
Wework Central, #36 Infantry Road,  
**Bengaluru - 560 001**  
Phone No: 022-6932 7800  
e-mail: CIC@LK-EA.com

Lauritz Knudsen Electrical & Automation  
AWFIS Space Solutions, Prestige Phoenix,  
4th floor, 1405, Umanagar, Begumpet,  
**Hyderabad - 500 016**  
Phone No: 022-6932 7800  
e-mail: CIC@LK-EA.com

Lauritz Knudsen Electrical & Automation  
El Dorado Building, 3rd Floor, 6,  
Venkatraman Street, Chinna Chokkikulam,  
**Madurai - 625 002**  
Phone No: 022-6932 7800  
e-mail: CIC@LK-EA.com

Lauritz Knudsen Electrical & Automation  
UrbanWrk, 5th Floor, Sai Radhe,  
Raja Bahadur Mill Road, Behind Hotel  
Grand Sheraton, Sangamwadi  
**Pune - 411 001**  
Phone No: 022-6932 7800  
e-mail: CIC@LK-EA.com

Lauritz Knudsen Electrical & Automation  
Workloop Unit-612, 6th Floor,  
Esplanade One, Rasulgarh,  
**Bhubaneswar, Odisha-751010**  
Phone No: 022 6932 7800  
e-mail: CIC@LK-EA.com

Lauritz Knudsen Electrical & Automation  
Worlie, 214 -2nd Floor,  
Apollo Premier, PU-4,  
Scheme No. 54, Vijay Nagar Square,  
**Indore - 452 010**  
Phone No: 022-6932 7800  
e-mail: CIC@LK-EA.com

Lauritz Knudsen Electrical & Automation  
Bestech Business Park,  
Tower - A, 2nd floor, Sector - 66  
**Mohali - 160059**  
Phone No: 022-6932 7800  
e-mail: CIC@LK-EA.com

Lauritz Knudsen Electrical & Automation  
Office No. 211 & 212, Pithalia Plaza,  
KK Road, Near Fafadih Chowk,  
**Rajpur - 492 001**  
Phone No: 022-6932 7800  
e-mail: CIC@LK-EA.com

Lauritz Knudsen Electrical & Automation,  
The Executive Centre  
Level 8, Olympia Teknos Park  
28, SIDCO Industrial Estate, Guindy,  
**Chennai - 600 032**, Tamil Nadu,  
Phone No: 022-6932 7800  
e-mail: CIC@LK-EA.com

Lauritz Knudsen Electrical & Automation  
Office No. 430, 4th Floor,  
Jaipur Electronic Market, Riddhi Siddhi,  
Gopalpura Bypass,  
**Jaipur - 302 018**  
Phone No: 022-6932 7800  
e-mail: CIC@LK-EA.com

Lauritz Knudsen Electrical & Automation  
TC II, Tower B, PRIMA BAY Gate No. 5,  
Saki Vihar Road Powai,  
**Mumbai - 400 072**  
Phone No: 022-6932 7800  
e-mail: CIC@LK-EA.com

Lauritz Knudsen Electrical & Automation,  
DevX 4th Floor, A Wing, Om 9 Square,  
150 Ft Ring Road, Near Nana Mava Circle,  
Opp Silver Heights,  
**Rajkot - 360 001**  
Phone No: 022-6932 7800  
e-mail: CIC@LK-EA.com

Lauritz Knudsen Electrical & Automation  
Playworkz Coworking Space  
43 & 44, 3rd Cross,  
Bharathy Colony, Peelamedu,  
**Coimbatore - 641 004**  
Phone No: 022-6932 7800  
e-mail: CIC@LK-EA.com

Lauritz Knudsen Electrical & Automation  
GDR Siddha, Ground Floor, N Road  
Bistupur, Opposite St. Mary's Church,  
**Jamshedpur - 831 001**  
Phone No: 022-6932 7800  
e-mail: CIC@LK-EA.com

Lauritz Knudsen Electrical & Automation  
Unnati Building, 2nd Floor,  
Automation Campus, A-600, TTC Industrial  
Area Shil-Mahape Road, Mahape,  
**Navi Mumbai - 400 710**  
Phone No: 022-6932 7800  
e-mail: CIC@LK-EA.com

Lauritz Knudsen Electrical & Automation  
10th Floor, Titaanium Business,  
Bhimrad Road, Althan  
**Surat - 395 017**  
Phone No: 022-6932 7800  
e-mail: CIC@LK-EA.com

Lauritz Knudsen Electrical & Automation  
3rd Floor, 1&2 Vijay Park,  
Main Chakrata Road, Opp. Anandam,  
Near Ballupur chowk,  
**Dehradun - 248 001**  
Phone No: 022-6932 7800  
e-mail: CIC@LK-EA.com

Lauritz Knudsen Electrical & Automation  
Business Communication Centre  
2nd Floor, Chiramel Chambers,  
Kurisupally Road, Ravipuram,  
**Kochi - 682 015**  
Phone No: 022-6932 7800  
e-mail: CIC@LK-EA.com

Lauritz Knudsen Electrical & Automation  
M1 & M2, Mezzanine Floor,  
Himalaya Excellency,  
Plot No. C-47, Pratap Nagar Square,  
**Nagpur - 440 022**  
Phone No: 022-6932 7800  
e-mail: CIC@LK-EA.com

Lauritz Knudsen Electrical & Automation  
11th Floor, Block-D, Notus IT Park,  
Sarabhai Campus, Bhailal Amin Marg,  
**Vadodara - 390 023**  
Phone No: 022-6932 7800  
e-mail: CIC@LK-EA.com

Lauritz Knudsen Electrical & Automation  
Ground Floor, B-27,  
Biplab Rashbihari Sarani,  
Sector 2A, Bidhan Nagar,  
**Durgapur - 713 212**  
Phone No: 022-6932 7800  
e-mail: CIC@LK-EA.com

Lauritz & Knudsen Electrical & Automation,  
207, 2nd floor, Revolution Complex,  
Station Road, E Ward,  
Next to Pedestrian Bridge,  
**Kolhapur - 416 001**  
Phone No: 022-6932 7800  
e-mail: CIC@LK-EA.com

Lauritz Knudsen Electrical & Automation,  
3rd floor, Uttam Tower by Viraj Estate,  
Sharanpur Road,  
**Nasik - 422 002**  
Phone No: 022-6932 7800  
e-mail: CIC@LK-EA.com

Lauritz Knudsen Electrical & Automation  
Naga Chambers, 3rd Floor, D/No. 12-1-16,  
Plot No. 49, Survey No. 1051, Waltair Main Road,  
**Visakhapatnam - 530 002**  
Phone No: 022-6932 7800  
e-mail: CIC@LK-EA.com

Lauritz Knudsen Electrical & Automation  
6th Floor, Exotica Greens, A Block, 191,  
R G Baruah Road, Guwahati Central,  
**Guwahati - 781 005**  
Phone No: 022-6932 7800  
e-mail: CIC@LK-EA.com

Lauritz Knudsen Electrical & Automation  
2nd Floor, BN3, Salt Lake, Sector-V,  
**Kolkata - 700 091**  
Phone No: 022-6932 7800  
e-mail: CIC@LK-EA.com

Lauritz Knudsen Electrical & Automation  
A-25, 1st Floor, Imperia Complex,  
Moham Corporate Industrial Estate,  
Near Sarita Vihar Metro Station,  
Mathura Road,  
**New Delhi - 110 044**  
Phone no: 022-6932 7800  
e-mail: CIC@LK-EA.com

Product improvement is a continuous process. For the latest information and special application, please contact any of our offices listed here. Product photographs shown for representative purpose only.



**Lauritz Knudsen Electrical & Automation, Electrical Standard Product**  
A/600, Shil-Mahape Road, TTC Industrial Area, MIDC Thane, Navi Mumbai, 400 710,  
Maharashtra, Phone No: 022-6722 6300 | Web: www.LK-EA.com

Customer Interaction Center (CIC)  
Phone no: 022-6932 7800  
Web: www.LK-EA.com | e-mail: CIC@LK-EA.com