

**L&T SWITCHGEAR**

SAFE & SURE

## INSTRUCTION MANUAL

### MECHANICAL INTERLOCK KIT

MO - M44 - CS94390

MO - M45 - CS94391

MO - M55 - CS94393

**FOR MO 140 - MO 300**  
CONTACTORS

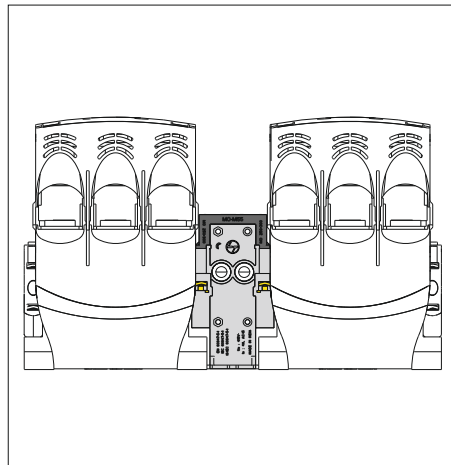



WARNING

Hazards of electric shock and burning. Installation, Commissioning and Maintenance to be done by qualified personnel only. Always use an appropriate voltage detection device to confirm the absence of voltage. Disconnect the power and isolate before proceeding with any work on this equipment. Use according to the operating instructions, professional practices, wiring rules, codes, safety regulations applicable to the installation.



CONTENTS  
UN PACKING

Carton, CFB sleeve, EPE buffer can be recycled after removal of the brass staples from the carton.



PRODUCT  
INSTALLATION

### **IMPORTANT INSTALLATION INSTRUCTIONS**

- 1) Use of Electrical Interlock with auxiliary NC contacts of Mechanical interlock is recommended for enhanced safety and reliability.
- 2) Do not use NC auxiliary contacts (21-22/41-42/61-62/81-82) of side add-on when Mechanical Interlock Kit MO-M44/45/55 is used.

## OVERALL DIMENSION

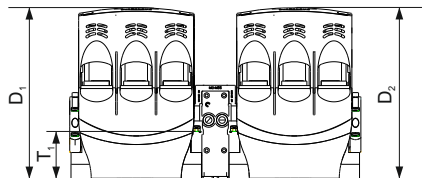

TYPE DESIGNATION	LABEL						
	H <sub>1</sub>	H <sub>2</sub>	D <sub>1</sub>	D <sub>2</sub>	W	T <sub>1</sub>	T <sub>2</sub>
MO-M45	225	197.5	170	190	295	52.6	42
MO-M45	197.5	225	190	170	295		
MO-M44	197.5	170	170	270			
MO-M55	225	190	320				

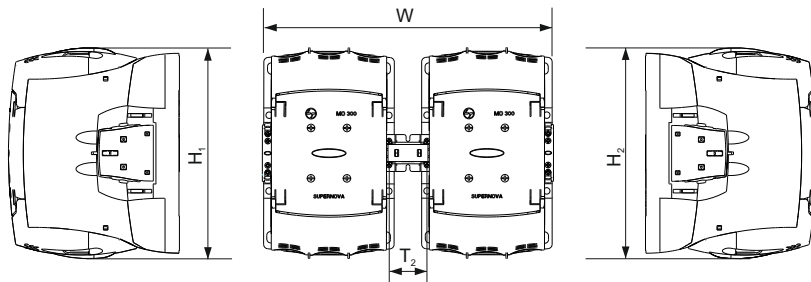

ALL DIMENSIONS ARE IN mm.

## MECHANICAL INTERLOCK KIT CONTENTS & ORDERING DETAILS

THE FOLLOWING TABLE GIVES DETAILS ABOUT THE MECHANICAL INTERLOCK KIT CONTENTS

MECHANICAL INTERLOCK CATALOGUE NO.	KIT CONTENTS	
	MECHANICAL INTERLOCK	HARDWARE SET POLYBAG
CS943900000	MO-M44	1 No.
CS943910000	MO-M45	1 No.
CS943930000	MO-M55	1 No.

THE FOLLOWING TABLE GIVES ORDERING DETAILS OF THE MECHANICAL INTERLOCK SUITABLE FOR THE CORRESPONDING CONTACTOR RATINGS

MECHANICAL INTERLOCK TYPE DESIGNATION	MECHANICAL INTERLOCK CATALOGUE NO.	CONTACTOR 1 RATING	CONTACTOR 2 RATING
MO-M44	CS943900000	MO 140/185/225	MO 140/185/225
MO-M55	CS943930000	MO 250/300	MO 250/300
MO-M45	CS943910000	MO 140/185/225	MO 250/300
MO-M45	CS943910000	MO 250/300	MO 140/185/225



PRODUCT INFORMATION

## DRILLING PLAN

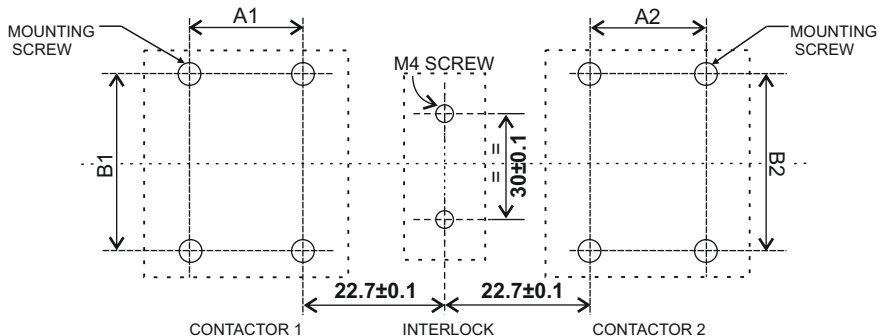

CONTACTOR 1 RATING	INTERLOCK DESIGNATION	CONTACTOR 2 RATING	DIM A1	DIM A2	DIM B1	DIM B2
MO 140/185/225	MO-M44	MO 140/185/225	105	105	160	160
MO 250/300	MO-M55	MO 250/300	130	130	187.5	187.5
MO 140/185/225	MO-M45	MO 250/300	105	130	160	187.5
MO 250/300	MO-M45	MO 140/185/225	130	105	187.5	160

CONTACTOR RATING	MOUNTING SCREW
MO 140/185/225	M5
MO 250/300	M6



PRODUCT  
INSTALLATION

ALL DIMENSIONS ARE IN mm.

## MECHANICAL INTERLOCK MOUNTING POSITION

✓ - CORRECT

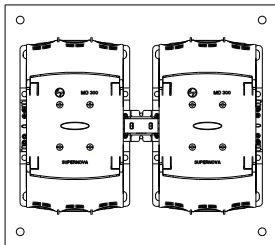

Fig. 1

MOUNT THE CONTACTOR WITH MOUNTING PLANE VERTICAL AS SHOWN IN Fig. 1

✗ - INCORRECT

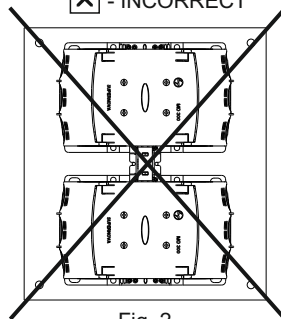

Fig. 2

MOUNTING THE CONTACTOR WITH MOUNTING PLANE ROTATED BY 90° AS SHOWN IN Fig. 2 IS NOT RECOMMENDED

✗ - INCORRECT

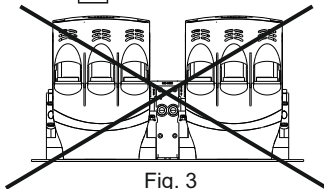

Fig. 3

MOUNTING THE CONTACTOR WITH MOUNTING PLANE IN HORIZONTAL CONDITION AS SHOWN IN Fig. 3 IS NOT RECOMMENDED



PRODUCT  
INSTALLATION

## MECHANICAL INTERLOCK FITMENT WITH TWO CONTACTORS OF SAME FRAME SIZE (SAME OVERALL DIMENSIONS)

1. REMOVE ADD-ON BLOCK FROM RIGHT HAND SIDE OF CONTACTOR 1 AND LEFT HAND SIDE OF CONTACTOR 2 AS SHOWN BELOW.

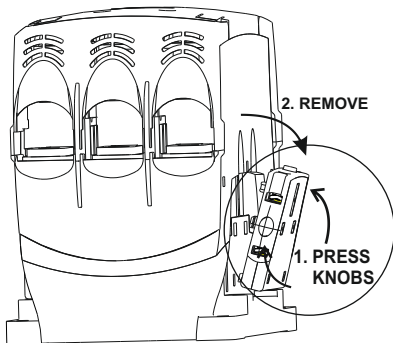

**CONTACTOR 1**  
**(Left Hand Side Contactor)**

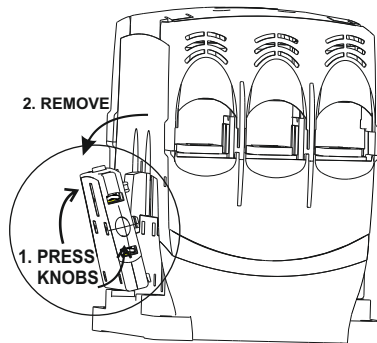

**CONTACTOR 2**  
**(Right Hand Side Contactor)**



PRODUCT  
INSTALLATION

2. FIX CONTACTOR 1 TO THE MOUNTING PLANE.
3. PLACE THE INTERLOCK CENTRALLY AS SHOWN AND PUSH TO ENSURE THAT ACTUATOR OF INTERLOCK IS ENGAGED IN THE CONTACTOR BRIDGE CAVITY.

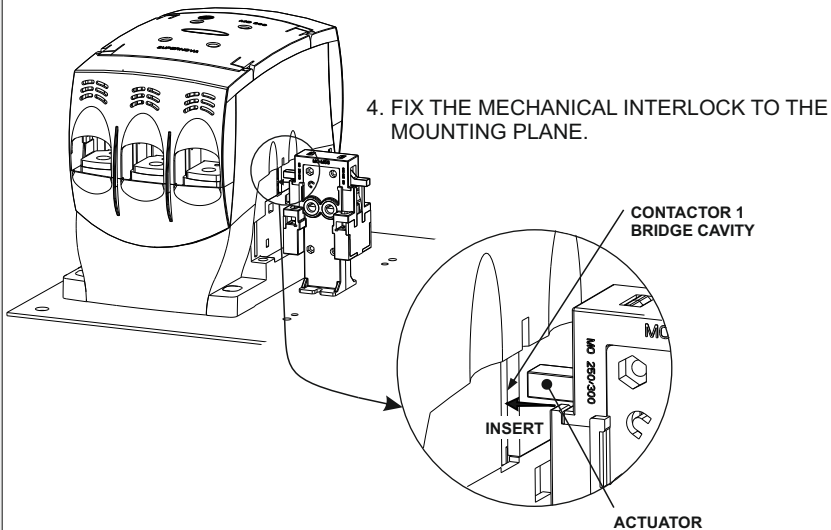

PRODUCT  
INSTALLATION

5. PLACE CONTACTOR 2 ON MOUNTING PLANE ENSURING THAT THE ACTUATOR OF INTERLOCK IS CENTRALLY ALIGNED AND ENGAGED IN THE CONTACTOR 2 BRIDGE CAVITY.

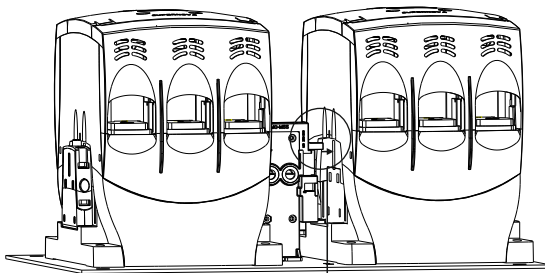

6. FIX THE CONTACTOR 2 TO THE MOUNTING PLANE.

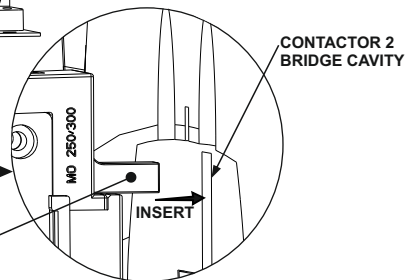

PRODUCT  
INSTALLATION

## MOUNTING INSTRUCTION FOR MECHANICAL INTERLOCK WITH DISSIMILAR FRAMES (DIFFERENT OVERALL DIMENSIONS)

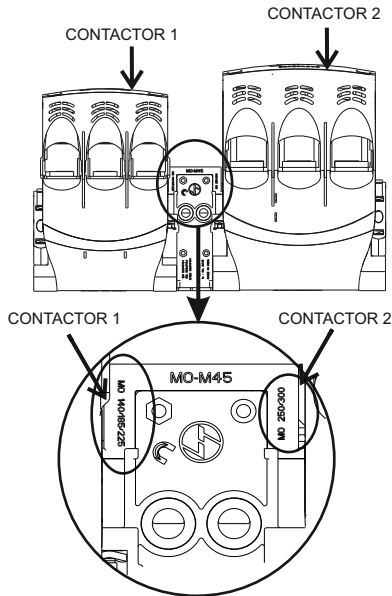

7. USE THE INTERLOCK MO-M45. ORIENTATION OF MECHANICAL INTERLOCK SHALL BE SUCH THAT RATING DESIGNATIONS PRINTED ON INTERLOCK COVER MATCHES THE CONTACTOR RATINGS ON THE RESPECTIVE SIDE AS SHOWN.
8. IN THE EXAMPLE SHOWN CONTACTOR 1 ON LEFT HAND SIDE IS OF FRAME SIZE 4 (MO 140/185/225) AND CONTACTOR 2 ON RIGHT HAND SIDE IS OF FRAME SIZE 5 (MO 250/MO 300).
9. IF THE CONTACTOR 1 ON LEFT HAND SIDE IS OF FRAME SIZE 5 (MO 250/300) AND CONTACTOR 2 ON RIGHT HAND SIDE IS OF FRAME SIZE 4 (MO 140/185/225) , THEN ROTATE THE MECHANICAL INTERLOCK BY 180° TO MATCH THE CONTACTOR RATINGS WITH THAT PRINTED ON MECHANICAL INTERLOCK COVER.



PRODUCT  
INSTALLATION

## IN-BUILT ELECTRICAL INTERLOCK

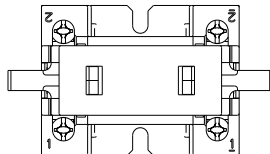

1. THE MECHANICAL INTERLOCK IS PROVIDED WITH TWO SETS OF NC CONTACTS (1-2) & (1-2), ONE EACH ON EITHER SIDE.
2. AUXILAIRY CONTACT TERMINATION DETAILS:

TERMINATION	CAPACITY
SOLID	2 x 1 - 4 mm <sup>2</sup>
STRANDED	2 x 1 - 2.5 mm <sup>2</sup>
PIN LUG	2 x 1 - 2.5 mm <sup>2</sup>
FORK LUG	1 x 2.5 mm <sup>2</sup>



PRODUCT  
INSTALLATION

## IMPORTANT INSTALLATION INTRUCTION

1. USE OF ELECTRICAL INTERLOCK WITH AUXILIARY NC CONTACTS OF MECHANICAL INTERLOCK IS RECOMMENDED FOR ENHANCED SAFETY AND RELIABILITY.

CONNECTION TO BE DONE AS PER BELOW CIRCUIT DIAGRAM FOR ELECTRICAL INTERLOCKING.

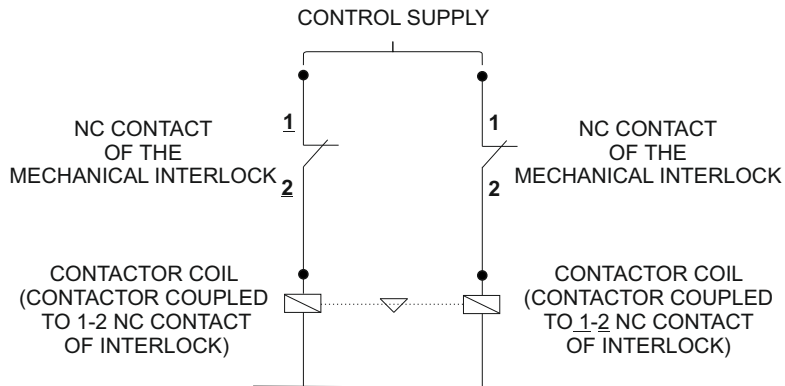

PRODUCT  
INSTALLATION

## IMPORTANT INSTALLATION INTRUCTION

- DO NOT USE NC AUXILIARY CONTACTS (21-22/41-42/61-62/81-82) OF SIDE ADD-ON WHEN MECHANICAL INTERLOCK KIT MO-M44/45/55 IS USED.

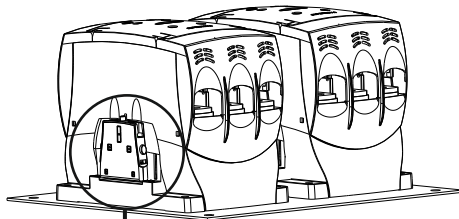

~~21/41/61/81  
NC~~

~~22/42/62/82  
NC~~

NC CONTACTS  
NOT TO BE USED



PRODUCT  
INSTALLATION

READ CAUTION LABEL PASTED ON  
THE SIDE ADDON BLOCK CAREFULLY

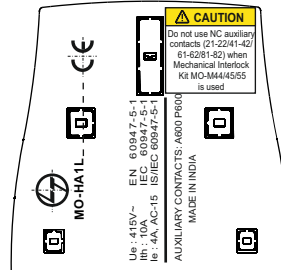



**DISCLAIMER  
NOTES**

"This literature gives information to user about product installation. This information is not exhaustive and should customer require further information, in specific cases, customer may contact customer interaction cell."

"The manufacturer assumes no responsibility for injuries, losses, damages to human beings and/or equipments due to inappropriate application of instructions, provided herein"

"Product development is a continuous process in L&T. The information given in this literature is subject to change. For latest information the customer may contact customer interaction cell"



**CUSTOMER  
CARE**

**CUSTOMER INTERACTION CELL (CIC) :** BSNL / MTNL (Toll-Free) : 1800 233 5858  
RELIANCE (Toll-Free) : 1800 200 5858  
Telephone : 022 6774 5858  
email : [cic@LNTEBG.com](mailto:cic@LNTEBG.com)  
website : [www.LNTEBG.com](http://www.LNTEBG.com)

SP00634

**L&T SWITCHGEAR**

SAFE & SURE

**L&T Electrical & Automation, Electrical Standard Products**

L&T Business Park, TC-2, Tower B, 3<sup>rd</sup> Floor, Gate No. 5,

Saki Vihar Road, Powai,

Mumbai - 400 072, INDIA. [www.Lntebg.com](http://www.Lntebg.com)