

# Getting started with xD1000



## 1 Introduction

This document guides the customer to realize a basic installation, wiring and functional debugging. If you need more information, please refer to instructions sheets and xD1000 user manual (SP51099) on <https://www.lk-ea.com>

### ⚠️ ⚠️ DANGER

#### HAZARD OF ELECTRIC SHOCK, EXPLOSION, OR ARC FLASH

Only appropriately trained persons who are familiar with and understand the contents of this manual and all other pertinent product documentation and who have received safety training to recognize and avoid hazards involved are authorized to work on and with this drive system. Installation, adjustment, repair and maintenance must be performed by qualified personnel.

- The system integrator is responsible for compliance with all local and national electrical code requirements as well as all other applicable regulations with respect to grounding of all equipment.
- Many components of the product, including the printed circuit boards, operate with mains voltage.
- Only use properly rated, electrically insulated tools and measuring equipment.
- Do not touch unshielded components or terminals with voltage present.
- Motors can generate voltage when the shaft is rotated. Prior to performing any type of work on the drive system, block the motor shaft to prevent rotation.
- AC voltage can couple voltage to unused conductors in the motor cable. Insulate both ends of unused conductors of the motor cable.
- Do not short across the DC bus terminals or the DC bus capacitors or the braking resistor terminals.
- Before performing work on the drive system:
  - Disconnect all power, including external control power that may be present. Take into account that the circuit breaker or main switch does not de-energize all circuits.
  - Place a **Do Not Turn On** label on all power switches related to the drive system.
  - Lock all power switches in the open position.
  - Wait 15 minutes to allow the DC bus capacitors to discharge.
  - Follow the instructions given in the chapter "Verifying the Absence of Voltage" in the installation manual of the product.
- Before applying voltage to the drive system:
  - Verify that the work has been completed and that the entire installation cannot cause hazards.
  - If the mains input terminals and the motor output terminals have been grounded and short-circuited, remove the ground and the short circuits on the mains input terminals and the motor output terminals.
  - Verify proper grounding of all equipment.
  - Verify that all protective equipment such as covers, doors, grids is installed and/or closed.

**Failure to follow these instructions will result in death or serious injury.**

## 2 Verify the delivery of the drive

Remove xD1000 from the packaging and verify that it has not been damaged.

Damaged products or accessories may cause electric shock or unanticipated equipment operation.

### ⚠️ ⚠️ DANGER

#### ELECTRIC SHOCK OR UNANTICIPATED EQUIPMENT OPERATION

Do not use damaged products or accessories.

**Failure to follow these instructions will result in death or serious injury.**

Contact your local Lauritz Knudsen Electrical & Automation sales office if you detect any damage whatsoever. Check that the drive catalog number printed on the label matches the delivery note and corresponding purchase order.

Write the drive Model catalog number: \_\_\_\_\_

and Serial Number: \_\_\_\_\_



## 3 Mount the drive vertically

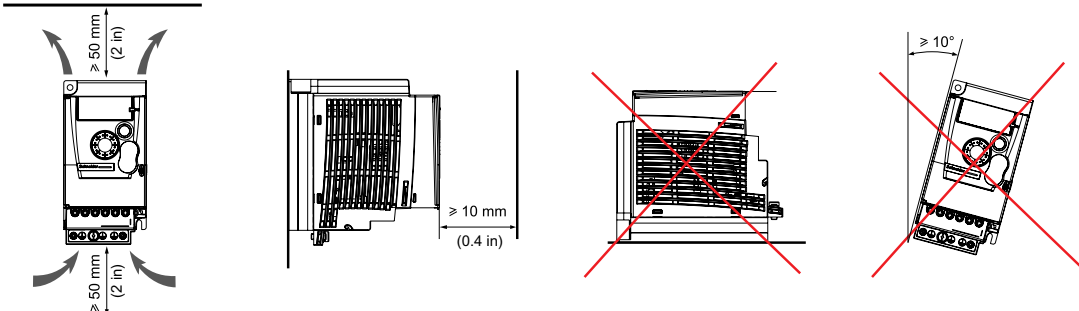

See user manual (SP51099) on <https://www.lk-ea.com> for other thermal conditions.

## 4 Connect the drive: Power

- Wire the drive to the ground. The grounding screws are shown in ①
- Wire the drive to the motor. The motor terminals are shown in ②
- Wire the drive to the main power supply, the power supply terminals are shown in ③

For drives 0.37 kW (HD) to 0.75 kW (HD)

For drives 1.5 kW (HD) to 5.5 kW (HD)

For drives 7.5 kW (HD) to 22 kW (HD)

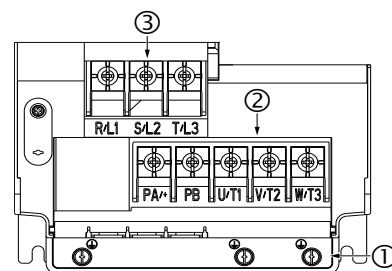
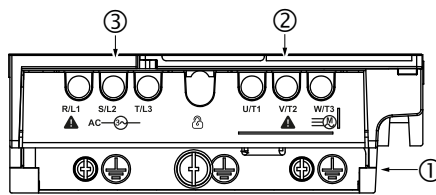
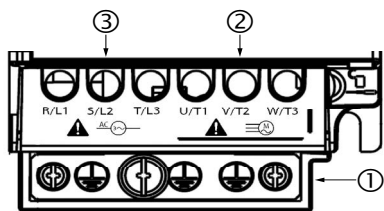

Suitable for use on a circuit capable of delivering not more than   X   rms symmetrical kilo Amperes, **690 Vac** Volts maximum, when protected by   Z1   with a maximum rating of   Z2  .

Current limiting fuses can be chosen as SCPD according to the following table for both Normal duty (ND) and Heavy duty (HD):

Reference	Fuse TYPE	Minimum Size	Nominal Voltage	Nominal current (Z1, Z2)	I <sup>2</sup> t	SCCR (X)	
			(V)	(A)		Min (A)	Max (kA)
XD1000-01P5-4B1111	gR	10x38	690	4	6.48	100	5
XD1000-02P3-4B1111	gR	10x38	690	6	22	100	5
XD1000-04P1-4B2111	gR	10x38	690	12.5	50	200	5
XD1000-05P5-4B2111	gR	10x38	690	16	78	200	5
XD1000-08P9-4B2111	gR	10x38	690	20	137	200	5
XD1000-12P1-4B2111	gR	10x38	690	25	238	300	5
XD1000-16P0-4B2111	gR	14x51	690	40	609	500	22
XD1000-22P8-4B2111	gR	14x51	690	40	609	500	22
XD1000-30P0-4B2111	gS	000	690	63	881	1000	22
XD1000-36P0-4B2111	gS	000	690	80	1741	1500	22
XD1000-43P0-4B2111	gS	1	690	100	2747	1500	22
XD1000-60P0-4B2111	gS	00	690	125	6185	1500	22

### • Power terminal cover opening method

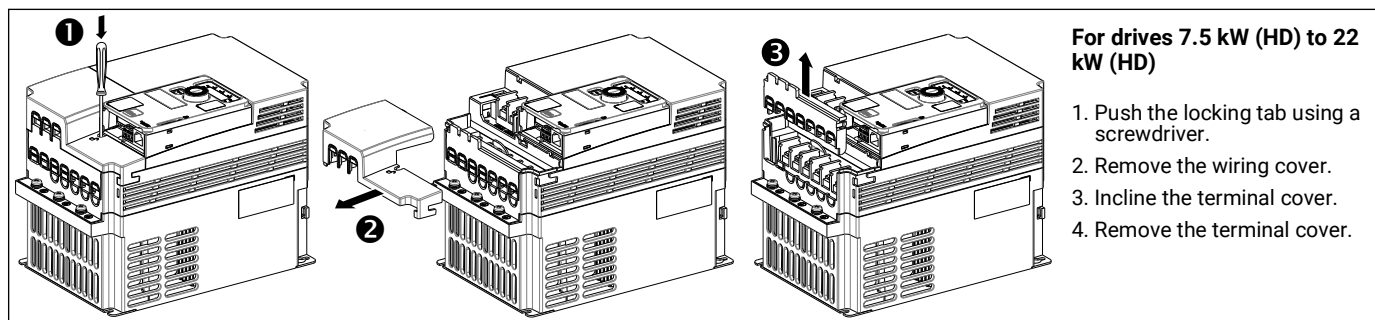
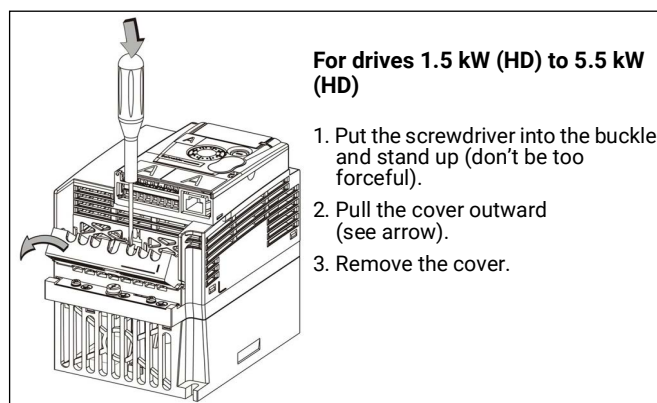
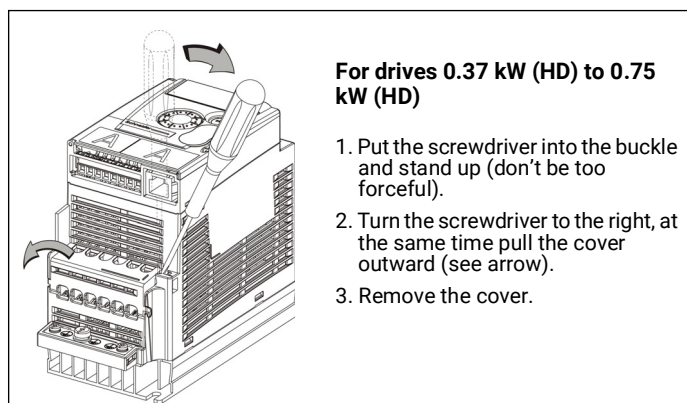

Screwdriver(s):

- For ≤ 18.5kW terminal wiring, use Phillips-head screwdriver PH2 (Ø6).
- For 22kW terminal wiring, use Phillips-head screwdriver PH2 (Ø6) or PH3 (Ø8).

## 5 Connect the drive: Control

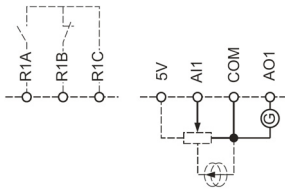

Factory setting channel:  
Controlled by terminal **4 0 1 = 1**

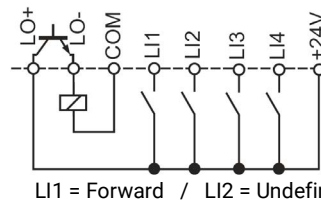

Logic input type is positive logic:  
**2 0 3 = 0 0**  
Control type is 2-wire control:  
**2 0 1 = 0 0**  
Macro setting:  
**1 0 0 = 0 0**

LI1 = Forward / LI2 = Undefined

## Modbus Connection (RJ45)

Connect the RJ45 cable connector to the xD1000 connector.

Pin out of the xD1000 RJ45 Connector

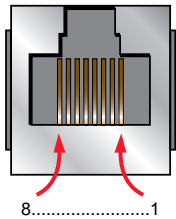

Pin	Signal
1	Reserved
2	
3	
4	D1 (1)
5	D0 (1)
6	Reserved
7	VP <b>Note:</b> Supply for RS232 / RS485 converter or a remote terminal.
8	Common (1) <div style="border: 1px solid black; padding: 5px; text-align: center;"><b>NOTICE</b> <b>RISK OF SERIAL PORT DAMAGE</b> Do not connect shield layer of the cable to Common (pin8). <b>Failure to follow these instructions can result in equipment damage.</b></div>

(1) Modbus signals.

## 6 Apply power to the drive

- Check that used Logic Inputs are not active.
- Apply power to the drive.
- Drive displays (see On next start-ups)

## 7 Set motor parameters

- Refer to the motor Nameplate for the following parameters settings.

Menu	Code	Description	Factory setting	Customer setting
<b>C o n F</b> → <b>F U L L</b> → <b>- 3 0 0 -</b> [Motor control menu]	<b>3 0 1</b>	[Standard motor frequency]: Standard motor frequency (Hz)	<b>5 0 . 0</b>	
	<b>3 0 2</b>	[Rated mot. power]: Nominal motor power on motor nameplate	drive rating	
	<b>3 0 5</b>	[Rated mot. current]: Nominal motor current on motor nameplate (A)	drive rating	
<b>C o n F</b> → <b>6 0 0</b> → <b>- 6 0 4 -</b> [Motor thermal protection menu]	<b>6 0 4</b>	[Motor thermal current]: Nominal motor current on motor nameplate (A)	drive rating	

## 8 Set basic parameters

Menu	Code	Description	Factory setting	Customer setting
<b>5 0 0</b> → <b>5 0 1 -</b> [Ramp menu]	<b>5 0 1 . 0</b>	[Acceleration]: Acceleration time (s)	<b>3 . 0</b>	
	<b>5 0 1 . 1</b>	[Deceleration]: Deceleration time (s)	<b>3 . 0</b>	
<b>5 0 0</b> → <b>5 1 2 -</b> [Speed Limit menu]	<b>5 1 2 . 0</b>	[Low speed]: Motor frequency at minimum reference (Hz)	<b>0 . 0</b>	
	<b>5 1 2 . 2</b>	[High speed]: Motor frequency at maximum reference (Hz)	<b>5 0 . 0</b>	

## 9 Start the motor

# Menu Structure

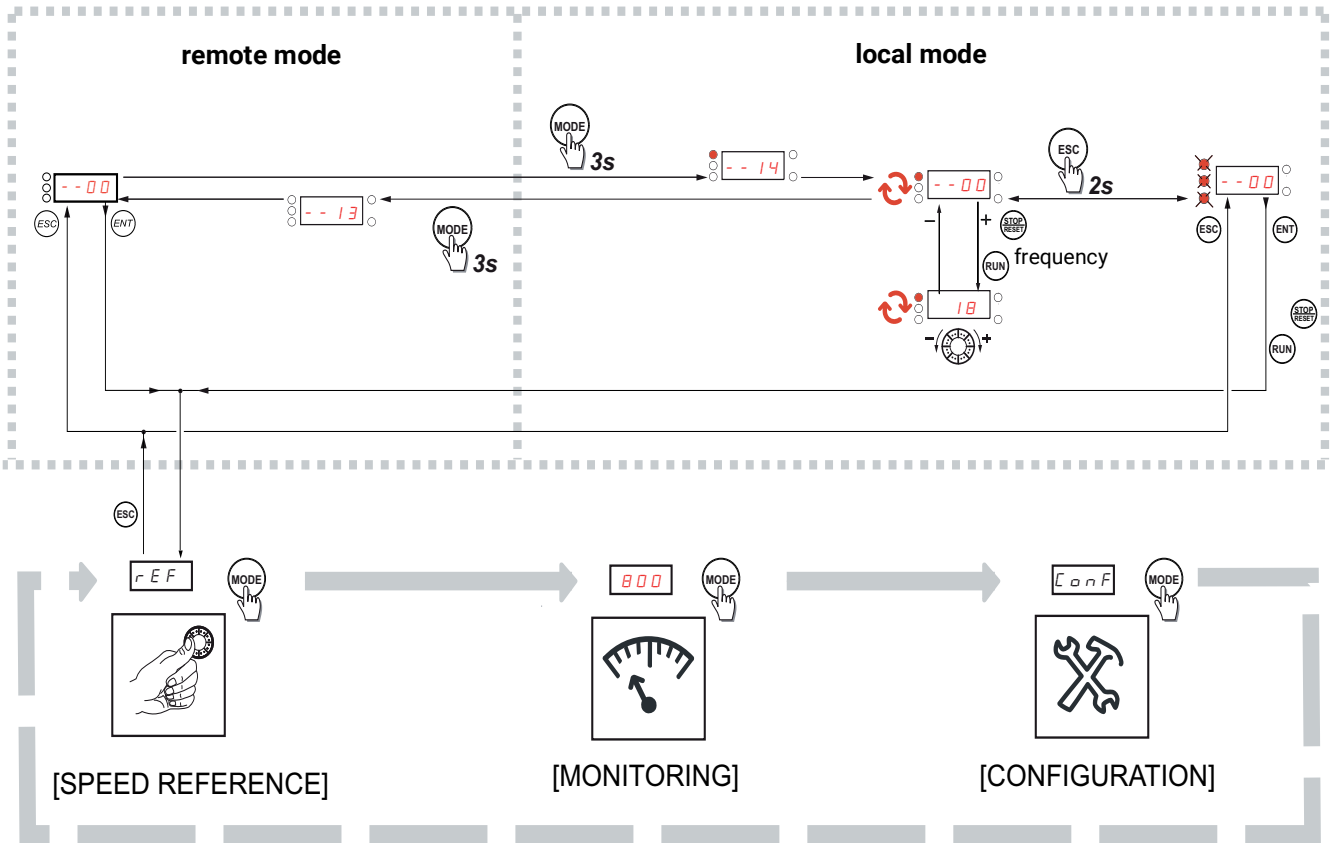

REFERENCE mode

