

CONTACTOR

MO 50/ MO 60/ MO 70

CS94572 MO 50
 CS94573 MO 60
 CS94574 MO 70

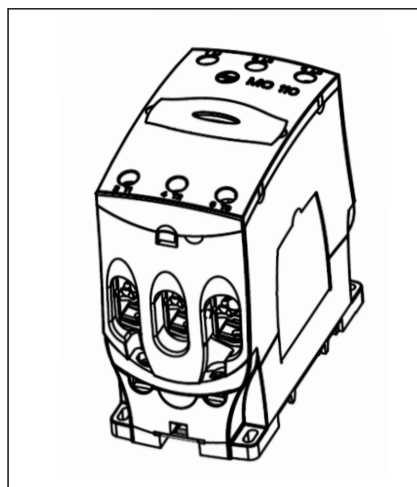

DISCLAIMER

The manufacturer assumes no responsibility for injuries, losses, damages to human beings and/or equipments due to

WARNING

Disconnect the power and isolate the product before proceeding with any work on this equipment. Always use an appropriate voltage detection device to confirm the absence of voltage. Installation to be done by qualified personal only. Hazards of electric shock and fire.

DISPOSAL INFORMATION

Packaging material (carton & padding) can be recycled. Poly bags can be recycled separately.

OVERALL DIMENSIONS

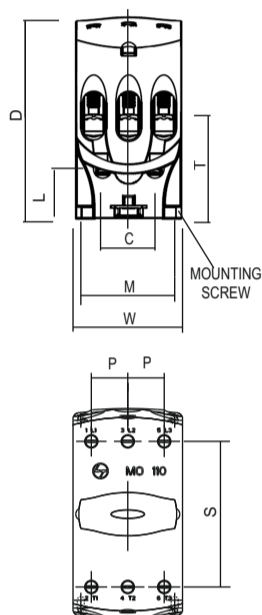

LABEL	MO 50/60/70	MO 80/95/110
W	55	70
D	122	134.5
H	123.5	135
M	45	60
T	68	68
C	27	35
L	29.5	30
S	82	93
P	18	23

ALL DIMENSIONS ARE IN mm.



MOUNTING ON DIN-RAIL

ENGAGE CONTACTOR WITH DIN RAIL AS SHOWN

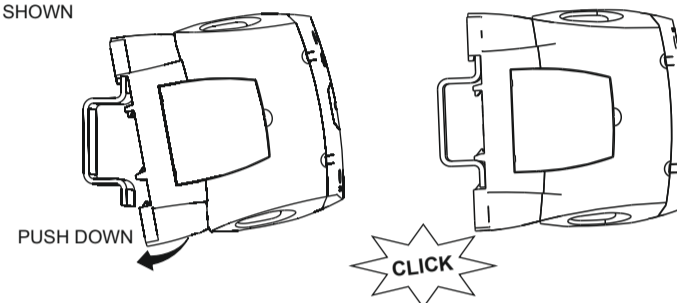

Conductor type	Termination capacity	
	MO 50-70	MO 80-110
Solid conductors (mm ²)	1 X 10 - 35 or 2 X 6 - 35	1 X 25 - 70 or 2 X 16 - 70
Stranded conductors (mm ²)	1 X 10 - 35 or 2 X 6 - 35	1 X 25 - 70 or 2 X 16 - 70
Insulated pin type lug (mm ²)	1 X 10 - 35 or 2 X 6 - 25	1 X 25 - 70 or 2 X 16 - 35
Insulated ferrule type lug (mm ²)	1 X 10 - 35 or 2 X 6 - 25	1 X 25 - 70 or 2 X 16 - 35

DRILLING PLAN

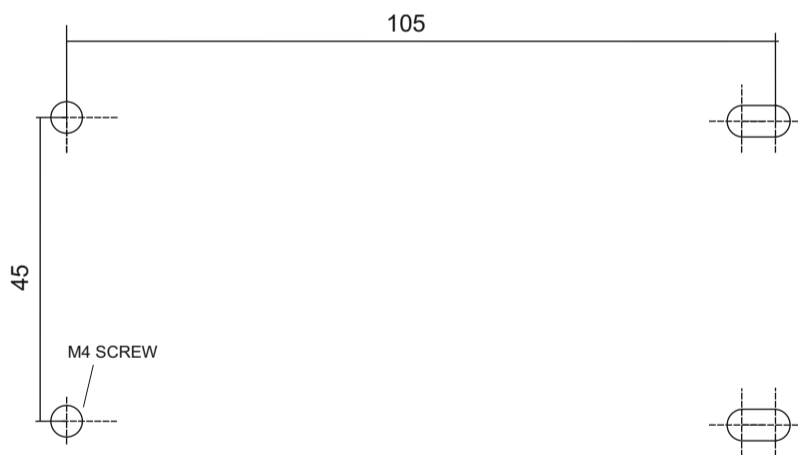

DRILLING PLAN FOR MO 50/60/70



ACCESSORIES

Accessories Description	Catalogue No.	Terminal Markings
Auxiliary Contact Blocks		
Side 1NO+1NC (First Right)	CS945800000	23-24, 31-32
Side 1NO+1NC (First Left)	CS945810000	33-34, 41-42
Side 1NO+1NC (Second Left)	CS945820000	53-54, 61-62
Side 1NO+1NC (Second Right)	CS945830000	73-74, 81-82
Top 1 NO - 1 Pole	CS945850000	53-54
Top 1 NC - 1 Pole	CS945860000	51-52
Top 2 NO - 2 Pole	CS945910000	53-54, 63-64
Top 1 NO+1 NC - 2 Pole	CS945920000	53-54, 61-62
Top 2 NC - 2 Pole	CS945930000	51-52, 61-62
Top 4 NO - 4 Pole	CS945940000	53-54, 63-64, 73-74, 83-84
Top 3 NO+1 NC - 4 Pole	CS945950000	53-54, 63-64, 73-74, 81-82
Top 2 NO+2 NC - 4 Pole	CS945960000	53-54, 63-64, 71-72, 81-82
Top 1 NO+3 NC - 4 Pole	CS945970000	53-54, 61-62, 71-72, 81-82
Top 4 NC - 4 Pole	CS945980000	51-52, 61-62, 71-72, 81-82
Mechanical Interlock kit	CS945840000	01-02, 01-02



TOP ADD-ON FITMENT

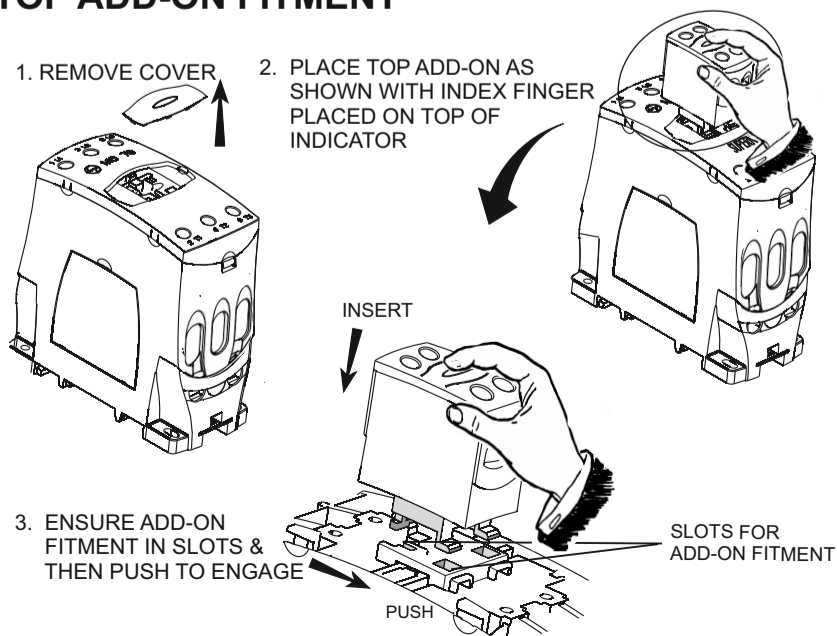

SIDE ADD-ON FITMENT

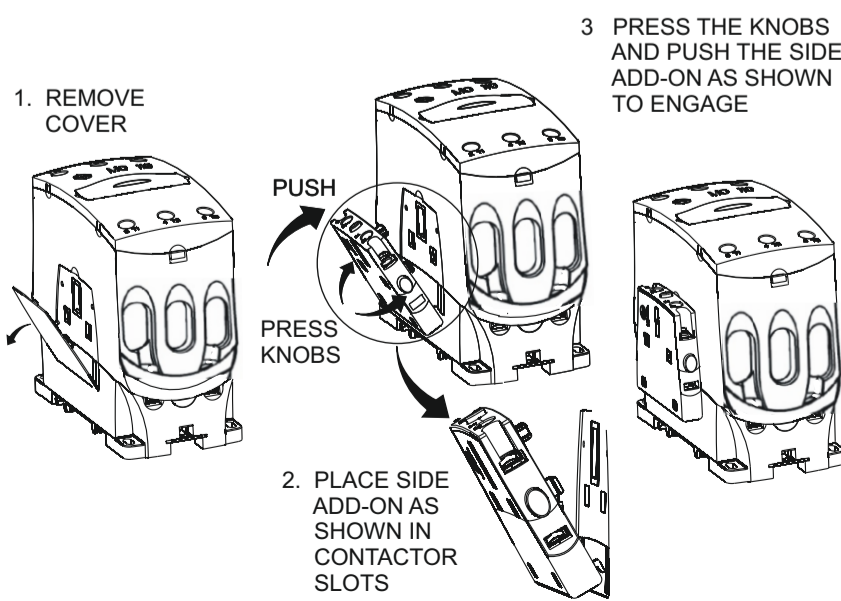

SECOND SIDE ADD-ON FITMENT

1. FOR SECOND AUXILIARY BLOCK REMOVE CUT-OUTS ON FIRST AUXILIARY BLOCK

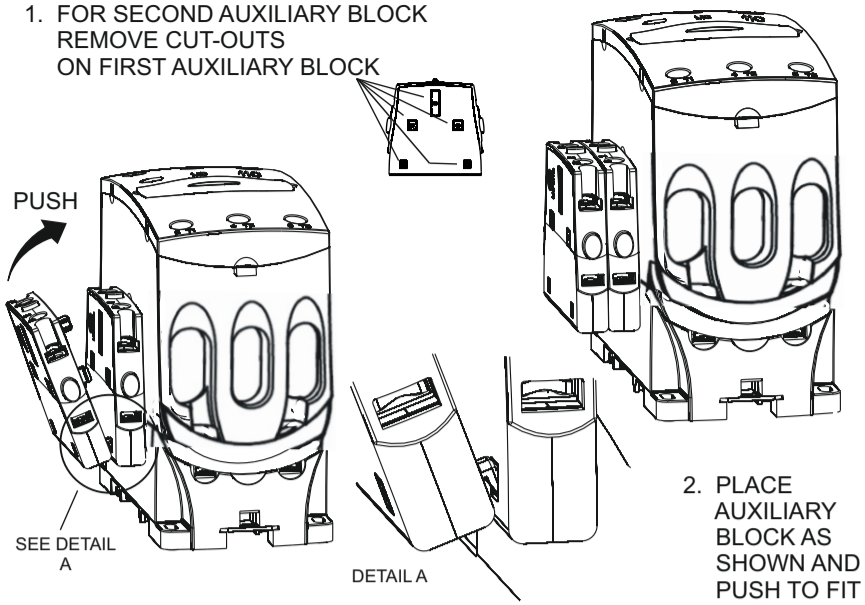

2. PLACE AUXILIARY BLOCK AS SHOWN AND PUSH TO FIT



PRODUCT OPERATION

MECHANICAL INTERLOCK FITMENT

1. REMOVE COVER AND ENGAGE PUSH FITS OF INTERLOCK IN CONTACTOR SLOTS AS SHOWN

2. PUSH THE INTERLOCK IN THE DIRECTION SHOWN TO FIT.

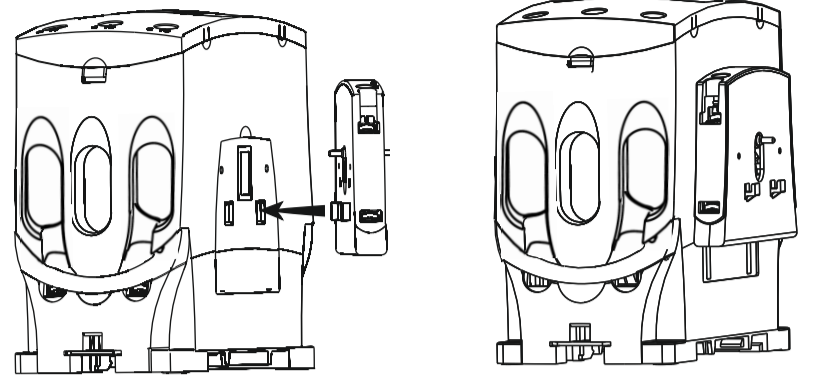

PRODUCT OPERATION

CLICK

MECHANICAL INTERLOCK FITMENT

3. ENGAGE SECOND CONTACTOR WITH INTERLOCK PROJECTIONS.

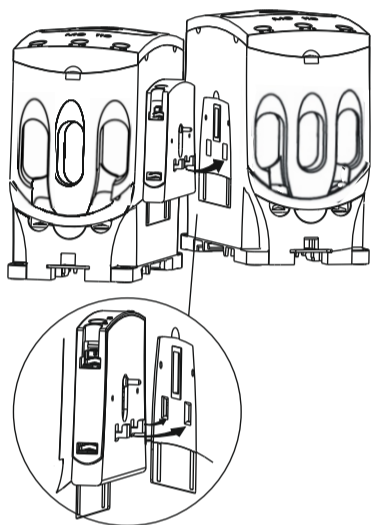

4. PUSH THE SECOND CONTACTOR DOWN TO ENSURE ALIGNMENT

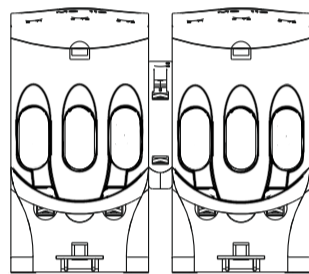

PRODUCT OPERATION

SURGE SUPPRESSOR

ORDERING INFORMATION

CS91706G000	24V	SURGE SUPPRESSOR FOR MO/MO C FR.0/1 CONTACTORS-MO S1
CS91706J000	42-48V	
CS91706A000	110V	
CS91706B000	220-320V	
CS91706D000	360-415V	
CS91706M000	525V	
CS91707G000	24V	SURGE SUPPRESSOR FOR MO/MO C FR.2 CONTACTORS-MO S2
CS91707J000	42-48V	
CS91707A000	110V	
CS91707B000	220-320V	
CS91707D000	360-415V	
CS91707M000	525V	
CS91708G000	24V	SURGE SUPPRESSOR FOR MO/MO C FR.3 CONTACTORS-MO S3
CS91708J000	42-48V	
CS91708A000	110V	
CS91708B000	220-320V	
CS91708D000	360-415V	
CS91708M000	525V	



PRODUCT OPERATION

SURGE SUPPRESSOR

OVERALL DIMENSIONS-MO/MO C FR.3 MO S3

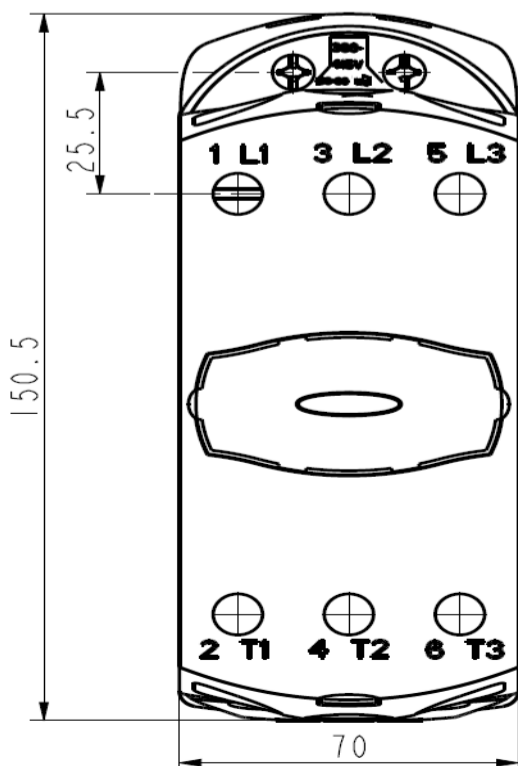
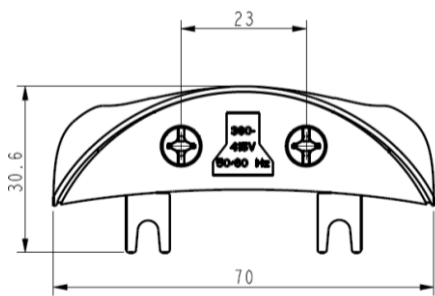

PRODUCT OPERATION

SURGE SUPPRESSOR FITMENT

1. LOOSEN THE SCREW-WASHER ASSEMBLY FROM THE TOP SIDE OF CONTACTOR (SIDE OPPOSITE TO DIN RAIL MOUNTING). REFER FIG. BELOW

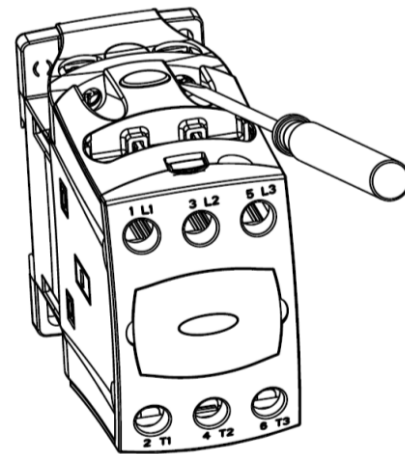

2. ASSEMBLE THE SURGE SUPPRESSOR ON THE COIL TERMINAL SLOTS AS SHOWN BELOW

3. TIGHTEN THE SURGE SUPPRESSOR ASSEMBLY INSIDE THE COIL TERMINAL SLOT WITH THE HELP OF SCREW-WASHER ASSEMBLY

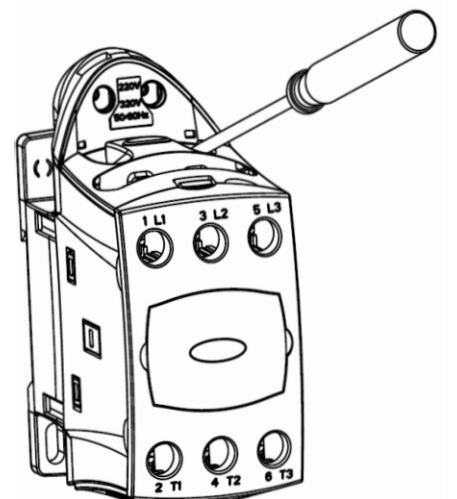
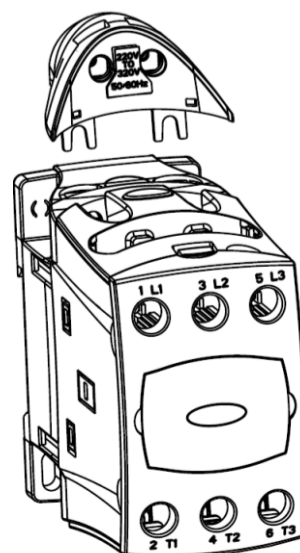

SPARES

Spares Description	Catalogue No.
Spare Coil-MO 50/60/70	CS96318* (ADD 4 DIGIT COIL VOLTAGE SUFFIX)
Spare Coil-MO 80/95/110	CS96319* (ADD 4 DIGIT COIL VOLTAGE SUFFIX)
Spare Contacts Kit MO 50	CS963870000
Spare Contacts Kit MO 60	CS963880000
Spare Contacts Kit MO 70	CS963890000
Spare Contacts Kit MO 80	CS963900000
Spare Contacts Kit MO 95	CS963910000
Spare Contacts Kit MO 110	CS963920000

*Add 4 digit suffix for coil voltage and type of coil termination
Last digit of suffix "O" - Screw type termination
Last digit of suffix "T" - Fast-on Termination



PRODUCT MAINTENANCE

COIL TERMINATION

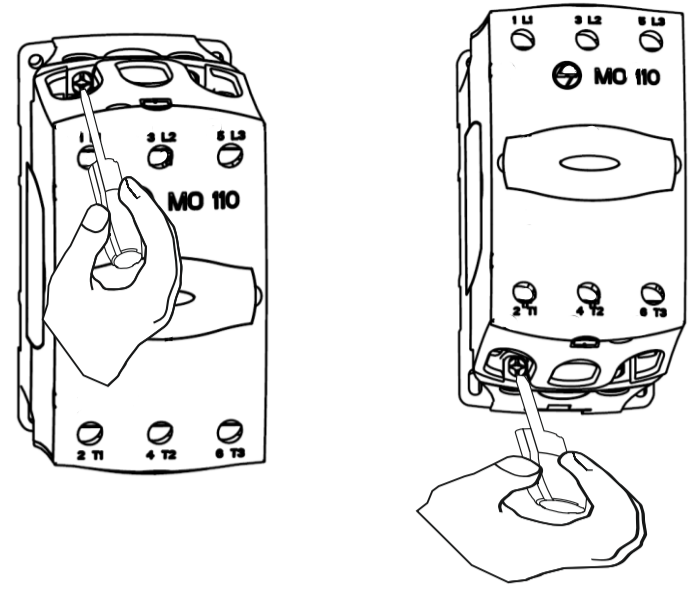

PRODUCT MAINTENANCE

COIL REPLACEMENT

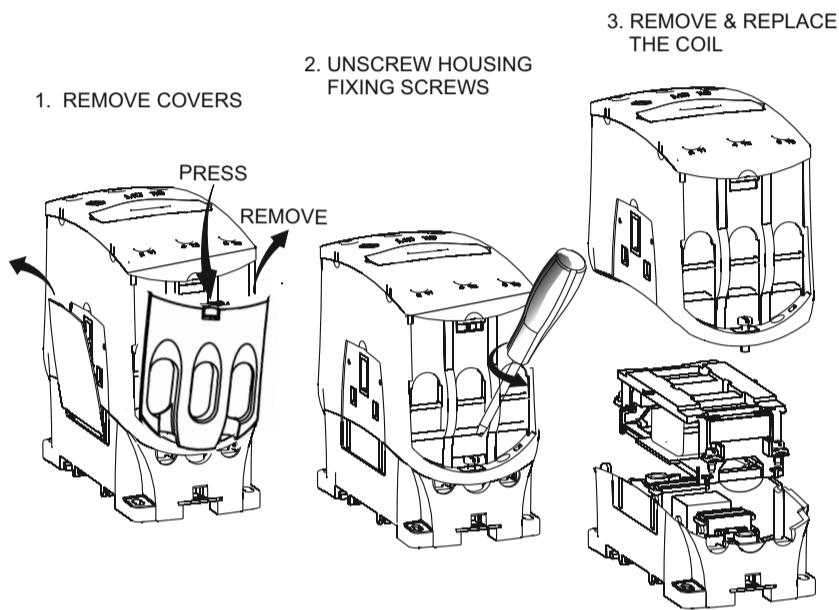

PRODUCT MAINTENANCE

CONTACT INSPECTION AND REPLACEMENT

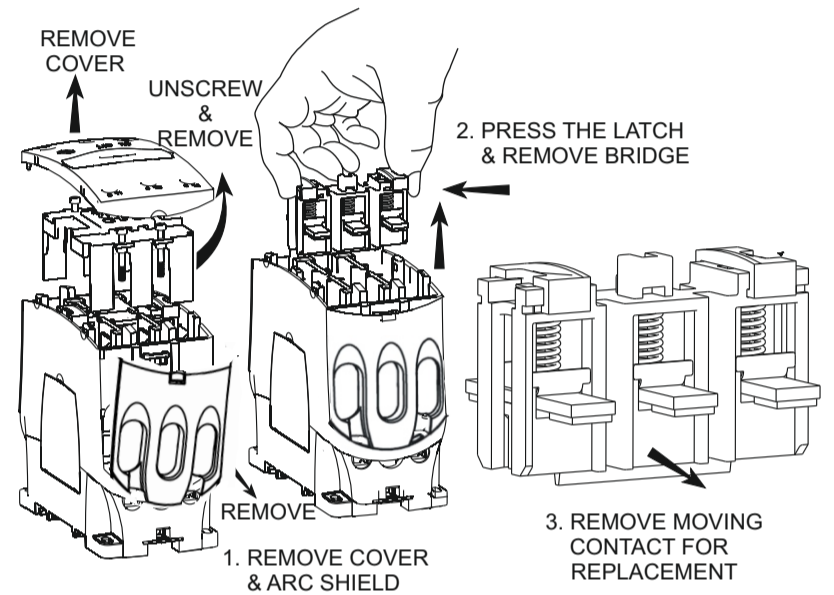

PRODUCT MAINTENANCE

CONTACT INSPECTION AND REPLACEMENT

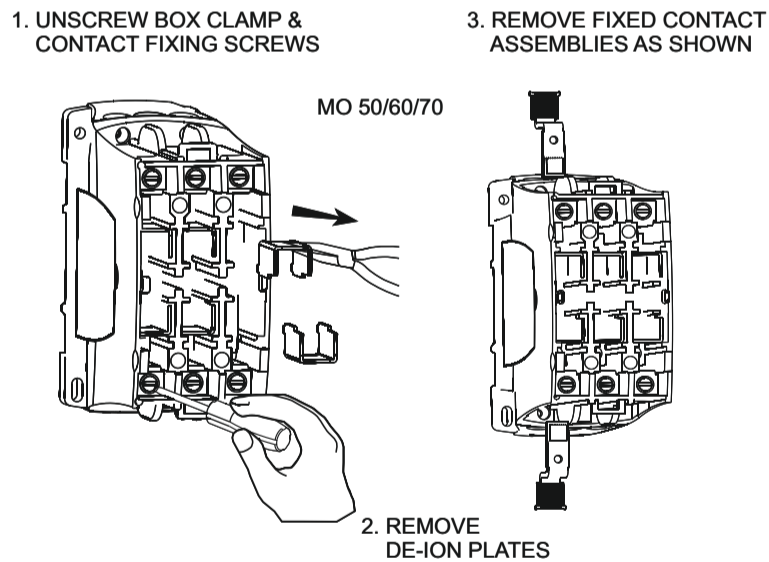

PRODUCT MAINTENANCE

CONTACT INSPECTION AND REPLACEMENT

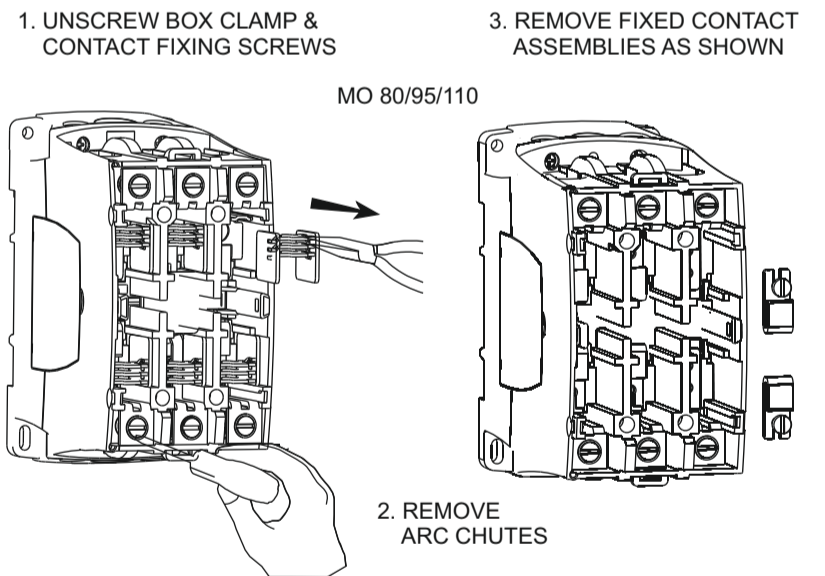

PRODUCT MAINTENANCE

CONTACT INSPECTION AND REPLACEMENT

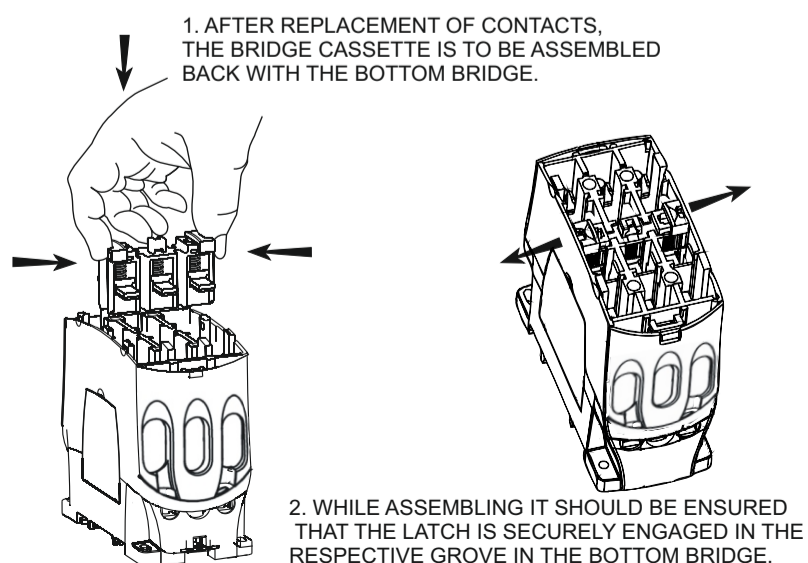

PRODUCT MAINTENANCE



DISCLAIMER NOTES

"This literature gives information to user about product installation, operation maintenance and disposal. This information is not exhaustive and should customer require further information, in specific cases, customer may contact customer interaction cell."

"The manufacturer assumes no responsibility for injuries, losses, damages to human beings and/or equipments due to inappropriate application of instructions, provided herein."

"Product development is a continuous process. The information given in this literature is subject to change. For latest information the customer may contact customer interaction cell"



CUSTOMER CARE

CUSTOMER INTERACTION CELL (CIC)

BSNL / MTNL (Toll-Free): 1800 233 5858
RELIANCE (Toll-Free): 1800 200 5858
Telephone: 022 6774 5858
email: cic@LNTEBG.com
website: www.LNTEBG.com



COMPANY INFORMATION

SPOXXXX

L&T SWITCHGEAR
SAFE & SURE

L&T Electrical & Automation,
Electrical Standard Products,

L&T Business Park, TC-2, Tower B, 3rd Floor,
Gate No.5, Saki Vihar Road, Powai,
Mumbai - 400 072, INDIA. www.Lntebg.com

VER. X.X